

Dimension™ 650

**Multiprocess Welding
Power Source** 

Quick Specs

Heavy Industrial Applications

Fabrication and construction
Heavy manufacturing
MRO—maintenance/repair
Pressure tank/vessel fabrication
Shipbuilding
Refineries and foundries
Railcar manufacturing
Earth-moving equipment manufacturing

Processes

MIG (GMAW)
Flux-cored (FCAW)
Submerged arc (SAW)
Stick (SMAW)
TIG (GTAW)
Air carbon arc (CAC-A)
cutting and gouging
Rated: 10 mm carbons

Input Power 3-phase power
380/460 V, 50/60 Hz

Rated Output 650 A at 44 VDC,
100% duty cycle

Output Range 15–815 A, 10–65 V

Net Weight 71.7 kg (158 lb.)



Big capabilities in a smaller package.

Developed for harsh environmental conditions and output requirements that range from power-intensive to precise.

An unbeatable combination of durability, output, efficiency and capability—all in a smaller, easier-to-handle package. Inside its tough, corrosion-resistant, all-aluminum case is big power for heavy welding jobs and carbon arc gouging.

In addition to excellent stick and Lift-Arc™ TIG, the Dimension 650 also has excellent short-arc MIG characteristics for precise thin-metal welding performance.

All-aluminum construction helps the machine resist corrosion for long life.

Exclusive protection input inductor protects machine's performance and reliability from "dirty" input power.

Wind Tunnel Technology™ Internal air flow that protects electrical components and PC boards from dirt, dust, debris.

Fan-On-Demand™ operates only when needed reducing noise, power consumption, and the amount of airborne contaminants pulled through the machine.

High electrical efficiency and excellent power factor mean that you can get more welding done using less power.

Digital meters with SunVision™ technology enable welding parameters to be viewed with greater clarity than analog meters — at virtually any angle. Meters can be seen clearly even in direct sunlight.



Reduced size and weight. Weighing in at 71.7 kg (158 lb.), the Dimension 650 is 3.5 times lighter than the Dimension 652, making it easier to move around the shop, jobsite, or shipyard. Requires 40-percent less floor space.

High-quality performance from power-intensive to precise. Knowing quality welds begin with a quality arc, we've significantly improved the performance in all welding processes and made it easy to fine tune the arc.

Gouging mode provides 800 amps of usable power, a full 650 amps of power at 100-percent duty cycle. Perfect for heavy gouging with 10 mm carbons.

Three wire modes (GMAW/FCAW/SAW) for simplified setup and optimized arc performance.

- Solid and flux-cored wires with gas offer exceptional short-arc MIG precision to weld thin metals with less risk of distortion or burn-through, and premium flux-cored welding with gas.
- Flux-cored (self-shielded) welding performance is exceptional, especially with wires commonly found in infrastructure construction.
- Sub arc mode provides capability to retrofit into non-digital sub arc applications.

Excellent stick and Lift-Arc™ TIG performance.

Arc control is active in the stick and solid-wire processes. It allows the operator to customize arc characteristics to match preference, electrode and joint design from a softer arc with more fluid puddle to a stiffer arc with an more controllable puddle.

Auxiliary power. 20 amps of 120 V power to run power tools—like grinders, chop saws, drills and lights.

TRUE BLUE®
3 YR. WARRANTY

Power source is warranted for three years, parts and labour.
Original main power rectifier parts are warranted for five years.



ITW Welding – BV

Edisonstraat 10
P.O. Box 1551
NL-3261 LD Oud-Beijerland,
Netherlands
TEL: +31 (0) 186 641 444
FAX: +31 (0) 186 640 880

ITW Welding – Italy S.r.l.

Via Privata Iseo 6/e
20098 San Giuliano M.se
Milano – Italia
TEL.: +39 02 982901
FAX: +39 02 98281552
ITW-Welding.com

International Headquarters Miller Electric Mfg. Co.

An Illinois Tool Works Company
1635 W. Spencer Street
Appleton, WI 54914 USA
TEL.: +1 920 735 4554
FAX: +1 920 735 4125
MillerWelds.com

Specifications (Subject to change without notice.)



Amperage/Voltage Ranges	Rated Output	Amps Input at Rated Output, 50/60 Hz				Max. Open-Circuit Voltage	Dimensions	Net Weight
		380 V	460 V	KVA	KW			
15–815 A in CC mode 10–44 V in CV mode 10–65 V in SAW mode	650 A at 44 VDC, 100% duty cycle	53.2	42.8	34	30.7	87	H: 716 mm (28.187 in.) (including lift eye) W: 424 mm (16.687 in.) D: 803 mm (31.625 in.)	71.7 kg (158 lb.)

Mounting Specifications

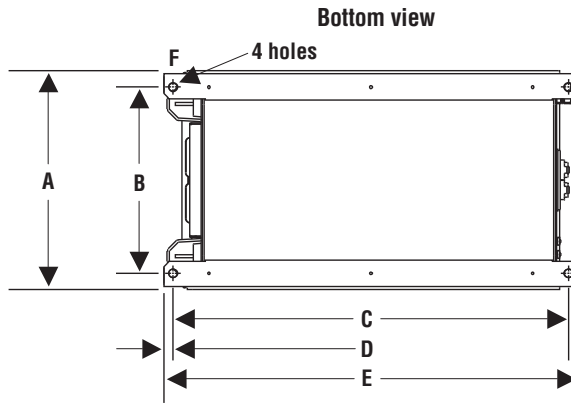

- A. 424 mm (16.687 in.)
- B. 362 mm (14.25 in.)
- C. 768 mm (30.25 in.)
- D. 44 mm (.687 in.)
- E. 803 mm (31.625 in.)
- F. 17 mm (.625 in.) dia.

Height: 716 mm (28.187 in.)
Width: 424 mm (16.687 in.)
Depth: 803 mm (31.625 in.)

Ordering Information

Equipment and Options	Stock No.	Description	Qty.	Price
Dimension™ 650	907618	380/460 V, 50/60 Hz		
Wire Feeders				
SuitCase® 12RC	301121	See literature M/6.5		
ST-24	029007395	See literature WFM/4.0		
ST-44	029007406	See literature MN/51.2		
I-24A	186943			
70 Series		See literature M/3.0		
Remote Controls				
Wireless Remote Foot Control	300429	Foot control with wireless 27.4 m (90 ft.) operating range		
Wireless Remote Hand Control	300430	Hand control with wireless 91.4 m (300 ft.) operating range		
RMLS-14	129337	Rocker switch		
RCC-14	151086	Fingertip control (east/west)		
RCCS-14	043688	Fingertip control (north/south)		
RHC-14	242211020 242211100	Hand control with 6 m (20 ft.) cord and 14-pin plug Hand control with 30.5 m (100 ft.) cord and 14-pin plug		
RFCS-14	043554	Foot control		
Options and Accessories				
Adapter Cord	301259	115 V. For legacy 14-pin accessories. Required to connect to HDC-1500		
Dimension 650 Running Gear	301307			
Insight Core™ 14-pin Module	301072	Easy-to-install module brings Insight Core capabilities to your existing fleet		
Coolant Systems				
Coolant	043810			
Primary Power Cable				
Secondary Welding Cables				
Work Cable and Clamp				

Date: _____ Total Quoted Price: _____

Distributed by:

