

4

3

2

1

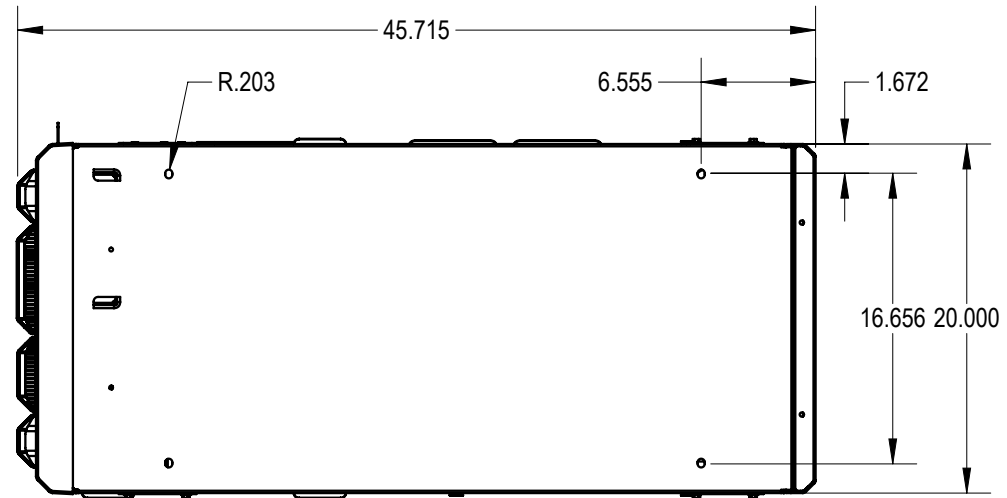
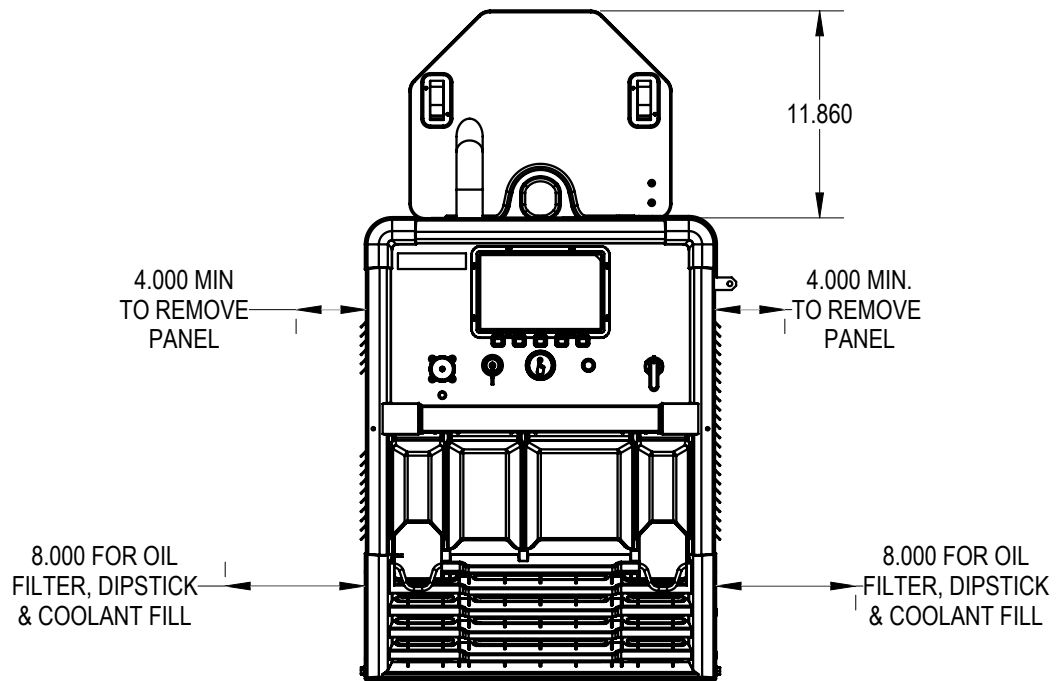
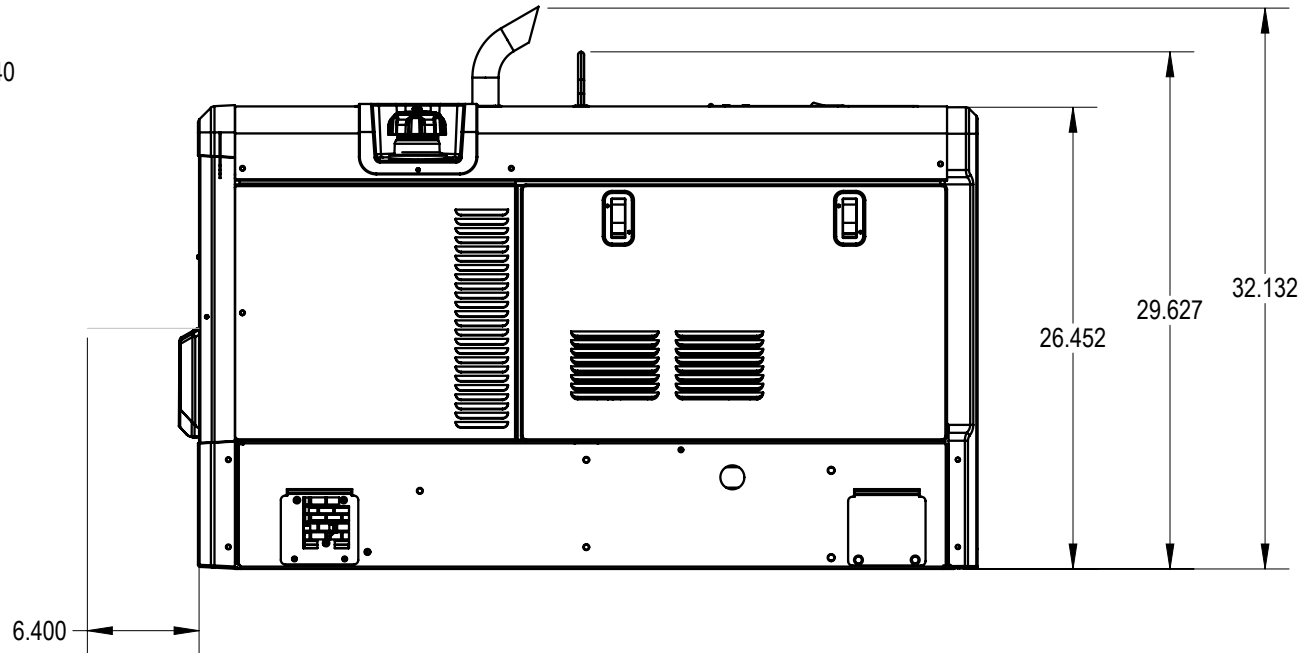
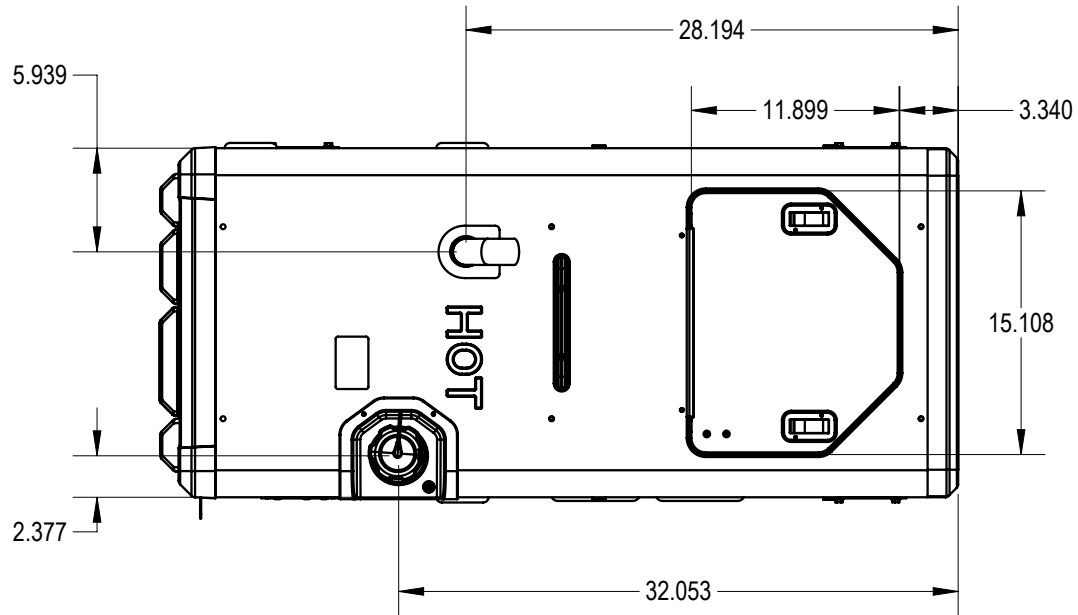

MINIMUM AIR FLOW REQUIREMENTS:

GENERATOR COOLING AIR IN LOWER FRONT 400 CFM.
GENERATOR COOLING AIR IN SIDE LOUVERS 1200 CFM.
GENERATOR/ENGINE EXIT AIR OUT REAR PANEL 1700 CFM.

EXTERNAL FUEL SUPPLY REQUIREMENTS:
4 PSI AT 500cc/MIN (3.05 C.I./MIN) FROM CUSTOMER SUPPLIED ELECTRIC FUEL PUMP. REMOVE MECHANICAL PUMP. COVER PORT WITH KUBOTA P/N'S 15852-52850 & 16264-52140. INSTALL ADDITIONAL FILTER IN FRONT OF THE ELECTRIC FUEL PUMP.

BYPASS LOW FUEL SHUTDOWN

CONNECT LEADS 38 AND 42 WITH INSULATED MATING TERMINALS

RoHS COMPLIANT

Rev	Date	By	ECO	Revision Description

Dimensions are in INCHES Unless Otherwise Specified

Decimal:
0.X ±
0.XX ±
0.XXX ±

Fractional ±
Angular ±

Machine Finish:

MILLER ELECTRIC MFG. LLC, APPLETON, WI. USA An ITW Welding Company

Title: ILLUS, TRAILBLAZER 330 DIESEL WORK TRUCK

NOT TO SCALE CONFIDENTIAL SHEET: 1 of 1

© MILLER ELECTRIC MFG. LLC ("MILLER"). THIS DOCUMENT FILE AND THE INFORMATION CONTAINED THEREIN ("MATERIAL") IS MILLER PROPRIETARY AND CONFIDENTIAL INFORMATION AND SHALL NOT BE DUPLICATED OR DISTRIBUTED WITHOUT MILLER'S EXPRESS WRITTEN CONSENT. THIS MATERIAL SHALL BE USED SOLELY FOR THE PURPOSE SET FORTH BY MILLER AND SHALL BE RETURNED TO MILLER UPON REQUEST.

Orig. Dwn. By: CL	Date: 12/18/23	Size: B	Drawing No: 296240	Rev: A
Rev. Appvd. By: CL	Date: 03/19/24			

4

3

2

1