

# Jetline® Longitudinal Seam Welders

Automation  
Systems



## Quick Specs

### Applications

Aerospace  
Tanks and vessels  
HVAC ducts  
Transportation  
Food and beverage  
Pharmaceutical  
Flexible hose/bellows  
Flexible filter materials  
...and many others

### Processes

TIG (GTAW)  
MIG (GMAW)  
Plasma arc welding (PAW)  
Submerged arc welding (SAW)

### Materials

Steel, titanium, copper, aluminum, tantalum, stainless steel, Inconel, Hastelloy, Monel and other weldable materials

### Input Power

120 V, 1-phase, 50/60 Hz  
Optional: 230/460 V, 3-phase, 50/60 Hz

### Compressed Air

80 psi (5.6 kg/sq. cm)

The linear welding speed and precision you depend on, both for today's needs and for the future, enabling high-volume cylinder production, joining thin-gauge metal, welding coiled sheets and more. A Jetline seam welder optimizes the welding process, reduces shrinkage and distortion, reduces welding costs and improves the quality of the weld.



Reliable and simple to operate.

Fast installation time.

Easily accommodates variations in material types, thicknesses, shapes and sizes.

Microprocessor- and computer-based control systems available.

Seam welders used for:

- Flat sheets
- Cylinders
- Cones
- Rectangles
- Ovals
- ...and other part configurations

Five different seam welder styles:

- External style
- Combination style
- Elevating style
- Flat sheet and internal style
- Bench style

Consult factory for special part configurations, sizes, shapes geometry or special applications.



Warrantied for three years, parts.



### Miller Welding Automation

An ITW Welding Company  
281 E. Lies Rd.  
Carol Stream, IL 60188 USA

### Equipment Sales

Phone: 630-653-6819  
Email: JetlineSales@millerwelds.com

### MillerWelds.com



## Standard Seam Welder Features

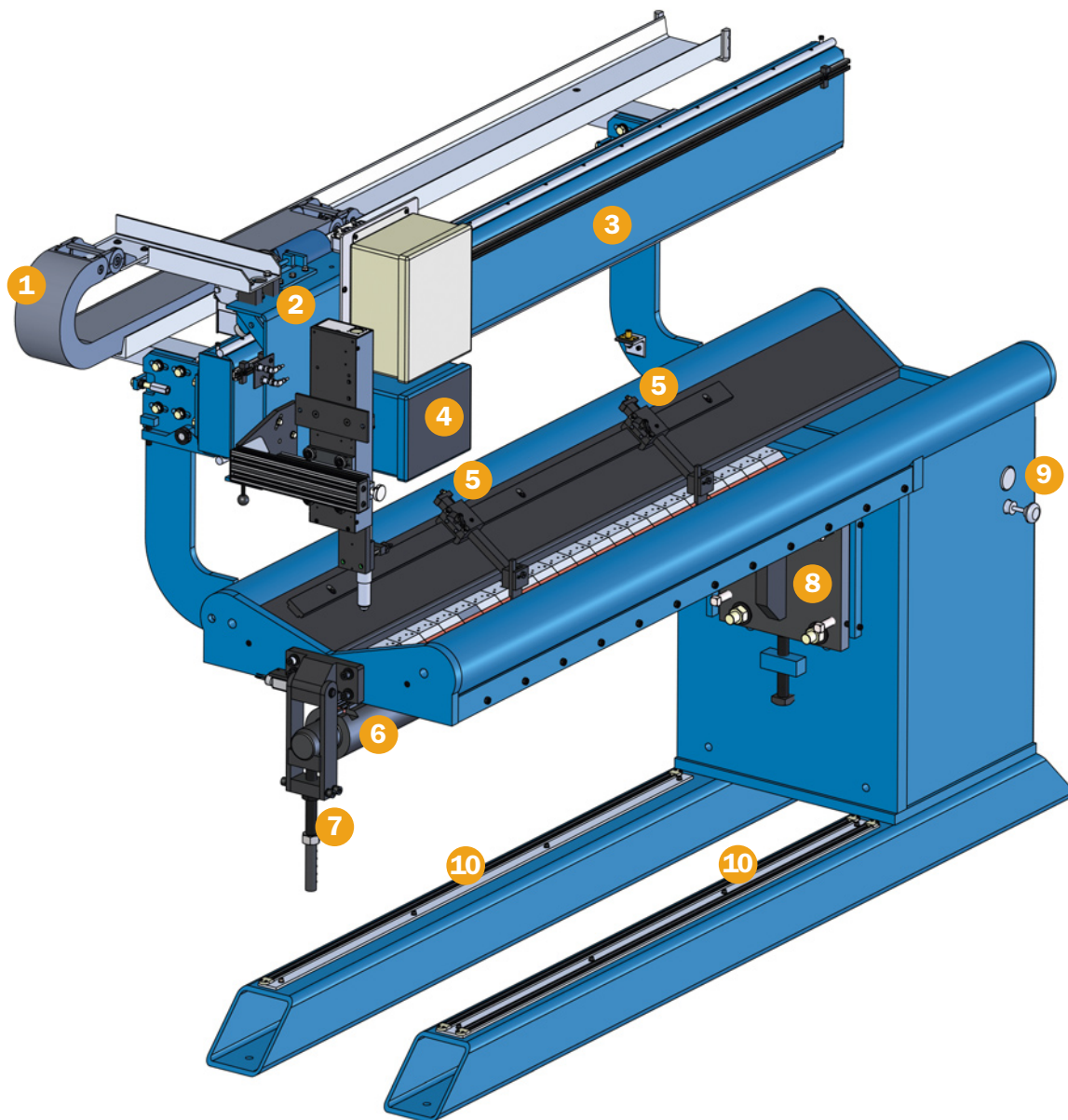

- 1. Flexible cable and hose support system** for cables and hoses going to the powered side beam carriage.
- 2. Powered side beam carriage** moves the torch along the weld joint.
- 3. Machined and stress-relieved side beam track** holds its accuracies for a lifetime. Allows for smooth and precise travel of the side beam carriage for a high-quality weld. Standard and precision tracks use a rack and pinion drive. The extra-precision seam welders use a high-precision linear drive.
- 4. 9700T control** sequences the starting and stopping of the weld process, controls side beam carriage movement and sequences optional accessories such as an arc length control, cold wire feeder, pneumatic torch lift and other accessories.
- 5. Two retractable edge alignment devices** are mounted on the seam welder. Additional alignment devices are available as an option. When positioned over the mandrel insert they assist the operator in aligning the part over the centerline of the insert groove. The alignment devices can easily be positioned anywhere along the length of the part.
- 6. Mandrel and backup insert.** All Jetline seam welders come with a copper backup insert mounted in the insert holder on top of the mandrel.
- 7. Mandrel latch** supports the open end of the mandrel. The **mandrel safety switch** assures the latch is closed prior to applying clamping pressure to the part.
- 8. Mandrel adjusts vertically** so the seam welder can accommodate a wide range of material thicknesses.
- 9. Clamping pressure adjustment and clamping pressure gauge.**
- 10. Toe touch strips** allow the operator to clamp and unclamp the fingers using their foot. The toe touch strips can easily be accessed from anywhere along the seam welder.

## Standard Seam Welder Features (Continued)

**Replaceable clamping fingers with dual-edge copper tips** are standard on every Jetline seam welder to assist with chilling the weld to reduce distortion and shrinkage from welding. The front bank of fingers clamp down and push in slightly towards the weld joint to form a tight butt joint.

**Adjustable clamping force of up to 5,000 lb./ft. (2,270 kg/ 300 mm)** to securely clamp the part during the weld.

**Copper backup insert** grooved to match the customer's application. The copper tooling pulls the heat from the part reducing the heat-affected zone.

**Manufactured with heavy-wall steel pipe, heavy-duty plates and extra gussets** minimizes deflection in the clamping fixture to reduce part distortion. The thick-wall construction helps provide a minimal amount of deflection when clamping pressure is applied as well as superior heat absorption and dissipation during welding.



**9700T microprocessor-based travel speed controller** is the standard controller supplied with all Jetline seam welders. The controller interfaces with suitable power supplies for weld sequence control. The 9700T controller also sequences arc length controls, cold wire feeders, pneumatic torch retractors, and magnetic or mechanical oscillators into the seam welder.

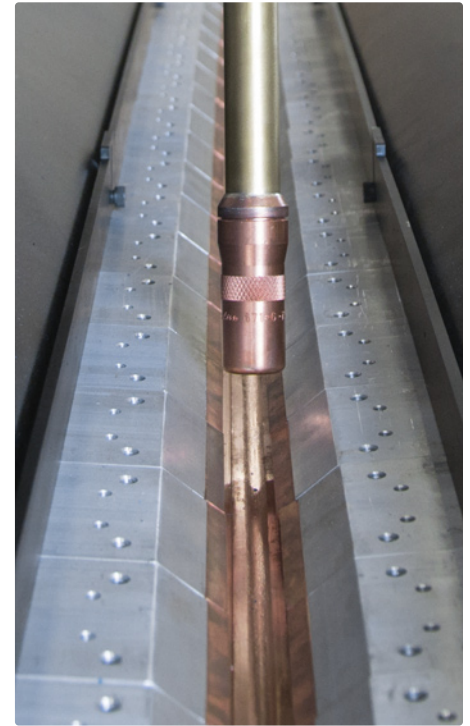

## Seam Welder Options

**Gas backup inserts** provide shielding gas to the backside of the weld.

**Backup inserts made from stainless steel or steel** can be provided instead of copper.

**Undersized mandrels** are available for welding smaller diameter parts.

**Riser blocks** increase the maximum part diameter the seam welder can accommodate.

**Water-cooled mandrel.**

**Clamping fingers with tips made from stainless steel or other materials** can be provided instead of copper.

**Dual pressure control** with low-pressure setting for loading the part and high-pressure setting for welding.

**Continuous finger strips mounted to each bank of clamping fingers** allow for welding materials under .020-inch thick.

**Custom mandrel shapes** for welding special part shapes.

**Step mandrels** on latch end of the seam welder for welds on short small-diameter parts.

**Two welding processes on one seam welder:** TIG and MIG, MIG and submerged arc, or TIG and plasma welding.

**Bracket packages** for mounting weld process to the seam welder carriage.

**Manual adjust and motorized slides** for height and cross seam adjustment of the torch.

**Lead/lag adjustment brackets** for mounting the torch.

**Pendant** for clamping and unclamping fingers.

**Foot pedals** can be supplied in place of the standard toe touch strips for clamping and unclamping the fingers.

**Material handling cart** for loading and unloading parts into the seam welder.

## Seam Welder Options (Continued)

**Laser line generator** provides a visual confirmation the part is loaded correctly and shows the path of the torch.

**Automatic pop-out alignment fingers** assist the operator in the loading of parts into the seam welder.

**Automatic finger adjustment** feature will allow the efficient “quick set” adjustment of all fingers on each bank of the seam welder by a simple turn of an Allen wrench at the latch end of the machine.

**Adjustable part stop** is used to position the part being welded in the same location on the mandrel each time a part is loaded into the seam welder. The part stop can be adjusted anywhere along the length of the mandrel to accommodate different part configurations.

**Droop mandrels** are available on the LWS, LWP, LWX and LWC seam welders. Droop mandrels allow for additional part clearance when loading and unloading parts into and out of the seam welder.

**Retractable mandrels** are available on the LWI seam welders. Retractable mandrel allows additional part clearance when loading and unloading parts into and out of the seam welder.

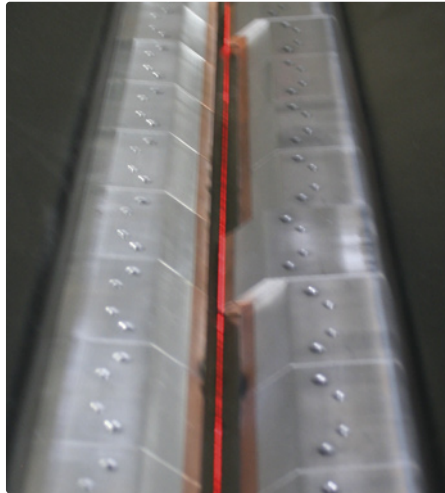

*Laser line generator*

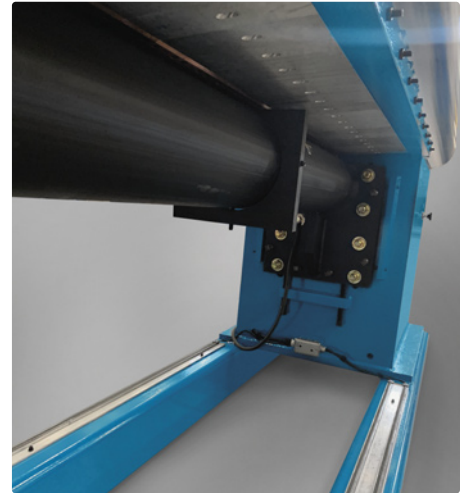

*Adjustable part stop*

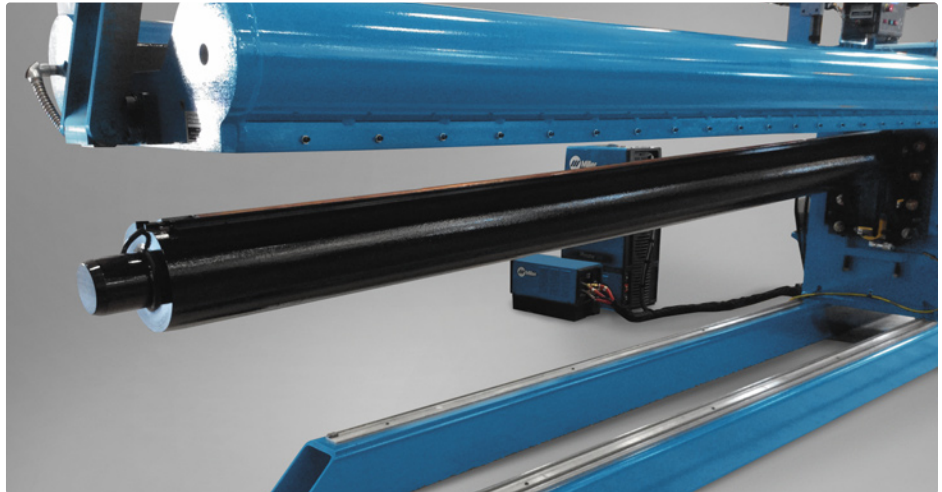

*Droop mandrel*

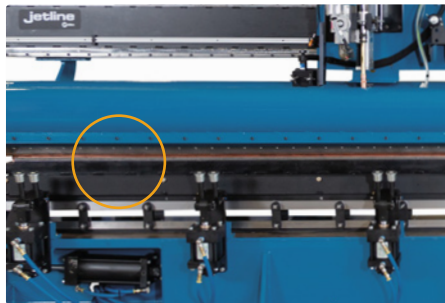

*Retractable mandrel up*

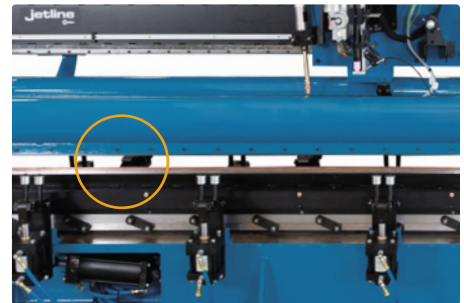

*Retractable mandrel down*

## External-Style Seam Welders

Designed for external welds on cylinders, flat sheets and many other shapes. Available in three levels of accuracy to optimize your seam welding application.

### LWS — Standard External-Style Seam Welder

- For all weldable metals
- For 0.020 to 3/8 inch (0.51 to 10 mm) thickness
- Rack and pinion carriage drive
- Travel accuracy is  $\pm 0.015$  inch (0.38 mm) per 10 feet (3 m)

### LWP — Precision External-Style Seam Welder

- Like standard, but designed for thinner materials
- For 0.010 to 3/8 inch (0.25 to 10 mm) thickness
- Continuous copper hold down strips are standard
- Travel accuracy is  $\pm 0.005$  inch (0.13 mm) per 10 feet (3 m)

### LWX — Ultra-Precision External-Style Seam Welder

- Like precision, but for critical applications
- For 0.005 to 3/8 inch (0.13 to 10 mm) thickness
- Linear drive replaces rack and pinion drive

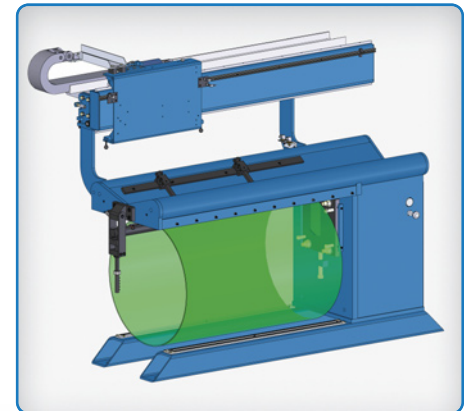

Consult factory for special part configurations, sizes, shapes, geometry or special applications.

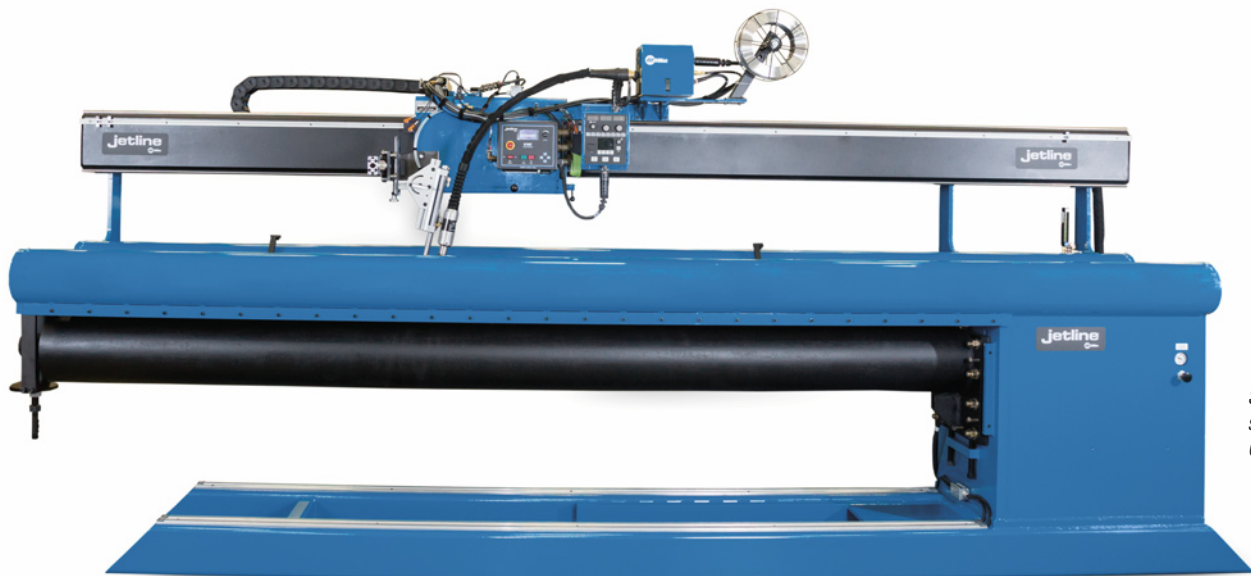

Seam welder shown with OPTIONAL items.

## Specifications (Subject to change without notice.)

Model No.*	Welding Length	Minimum Diameter Part	Dimensions (H x W x L)	Approx. Shipping Weight
LW_-24	24 in. (610 mm)	2.625 in. (67 mm)	69 x 40 x 70 in. (1,750 x 1,000 x 1,780 mm)	2,300 lb. (1,040 kg)
LW_-36	36 in. (915 mm)	3.50 in. (90 mm)	69 x 40 x 82 in. (1,750 x 1,000 x 2,080 mm)	2,600 lb. (1,180 kg)
LW_-48	48 in. (1,220 mm)	4.25 in. (108 mm)	69 x 40 x 94 in. (1,750 x 1,000 x 2,390 mm)	4,000 lb. (1,815 kg)
LW_-60	60 in. (1,525 mm)	5.25 in. (133 mm)	69 x 40 x 106 in. (1,750 x 1,000 x 2,690 mm)	4,700 lb. (2,130 kg)
LW_-72	72 in. (1,830 mm)	6.00 in. (152 mm)	69 x 40 x 118 in. (1,750 x 1,000 x 3,000 mm)	5,300 lb. (2,400 kg)
LW_-84	84 in. (2,135 mm)	6.875 in. (175 mm)	69 x 40 x 130 in. (1,750 x 1,000 x 3,300 mm)	5,900 lb. (2,675 kg)
LW_-96	96 in. (2,440 mm)	7.25 in. (184 mm)	69 x 40 x 142 in. (1,750 x 1,000 x 3,605 mm)	6,400 lb. (2,900 kg)
LW_-120	120 in. (3,050 mm)	9.50 in. (241 mm)	76 x 42 x 176 in. (1,930 x 1,070 x 4,470 mm)	12,000 lb. (5,450 kg)
LW_-144	144 in. (3,660 mm)	12.25 in. (311 mm)	76 x 42 x 200 in. (1,930 x 1,070 x 5,080 mm)	13,000 lb. (5,900 kg)
LW_-168	168 in. (4,270 mm)	15.25 in. (387 mm)	76 x 42 x 224 in. (1,930 x 1,070 x 5,690 mm)	14,000 lb. (6,350 kg)
LW_-192	192 in. (4,875 mm)	18.50 in. (470 mm)	76 x 42 x 248 in. (1,930 x 1,070 x 6,300 mm)	15,000 lb. (6,800 kg)
LW_-216	216 in. (5,485 mm)	21.25 in. (540 mm)	76 x 42 x 272 in. (1,930 x 1,070 x 6,900 mm)	16,000 lb. (7,250 kg)
LW_-240	240 in. (6,100 mm)	24.25 in. (616 mm)	76 x 42 x 296 in. (1,930 x 1,070 x 7,500 mm)	17,000 lb. (7,700 kg)

\* LW\_ : Use S (standard), P (precision) or X (ultra-precision) to designate model.

## Combination-Style Seam Welders

Designed for both internal and external welds on cylindrical tanks and vessels. Parts can be loaded either under the tabletop (smaller diameters) or around the tabletop (larger diameters).

### LWC — Combination-Style Seam Welder

- For all weldable metals
- For 0.020 to 3/8 inch (0.5 to 10 mm) thickness — options available for thinner materials
- Rack and pinion carriage drive
- Travel accuracy is  $\pm 0.015$  inch (0.4 mm) per 10 feet (3 m)
- Capable of external welds on parts up to 55-inch outside diameter with removable riser installed and parts up to 32-inch outside diameter without riser installed
- Capable of internal welds with minimum 55-inch outside diameter — maximum diameter is limited by your material handling capabilities

Consult factory for special part configurations, sizes, shapes, geometry or special applications.

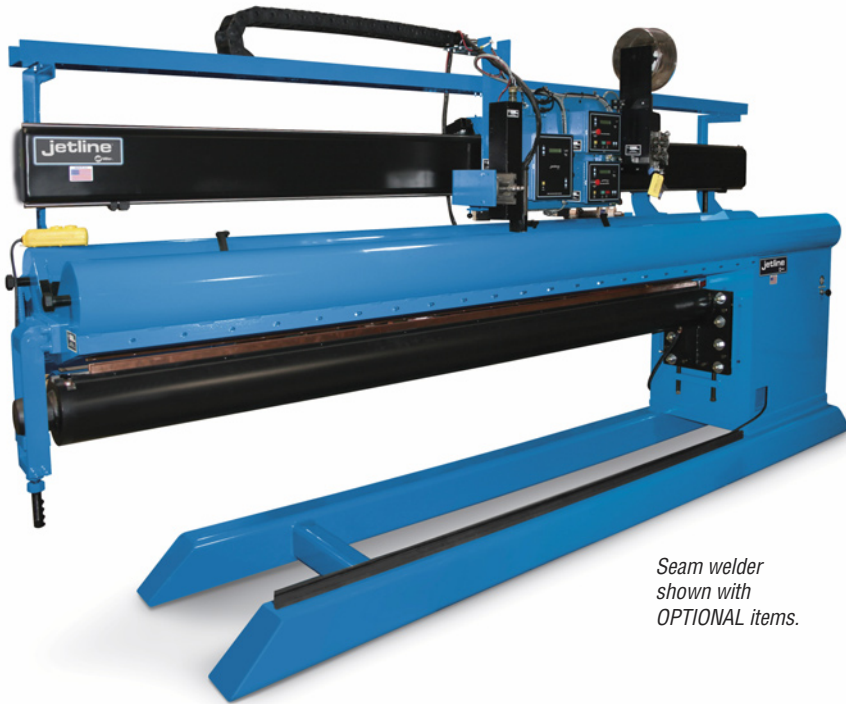

Seam welder shown with OPTIONAL items.

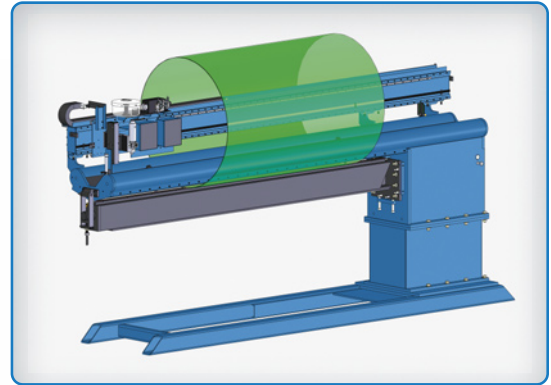
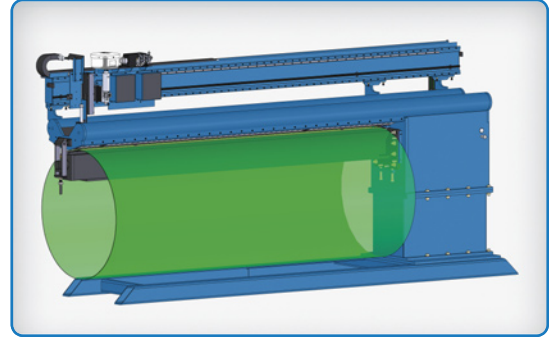

## Specifications (Subject to change without notice.)

Model No.	Welding Length	Minimum Diameter Part	Dimensions (H x W x L)	Approx. Shipping Weight
LWC-72	72 in. (1,830 mm)	6.00 in. (152 mm)	69 x 40 x 118 in. (1,750 x 1,000 x 3,000 mm)	5,300 lb. (2,400 kg)
LWC-84	84 in. (2,135 mm)	6.875 in. (175 mm)	69 x 40 x 130 in. (1,750 x 1,000 x 3,300 mm)	5,900 lb. (2,675 kg)
LWC-96	96 in. (2,440 mm)	7.25 in. (184 mm)	69 x 40 x 142 in. (1,750 x 1,000 x 3,605 mm)	6,400 lb. (2,900 kg)
LWC-120	120 in. (3,050 mm)	9.50 in. (241 mm)	76 x 42 x 176 in. (1,930 x 1,070 x 4,470 mm)	12,000 lb. (5,450 kg)
LWC-144	144 in. (3,660 mm)	12.25 in. (311 mm)	76 x 42 x 200 in. (1,930 x 1,070 x 5,080 mm)	13,000 lb. (5,900 kg)
LWC-168	168 in. (4,270 mm)	15.25 in. (387 mm)	76 x 42 x 224 in. (1,930 x 1,070 x 5,690 mm)	14,000 lb. (6,350 kg)
LWC-192	192 in. (4,875 mm)	18.50 in. (470 mm)	76 x 42 x 248 in. (1,930 x 1,070 x 6,300 mm)	15,000 lb. (6,800 kg)
LWC-216	216 in. (5,485 mm)	21.25 in. (540 mm)	76 x 42 x 272 in. (1,930 x 1,070 x 6,900 mm)	16,000 lb. (7,250 kg)
LWC-240	240 in. (6,100 mm)	24.25 in. (616 mm)	76 x 42 x 296 in. (1,930 x 1,070 x 7,500 mm)	17,000 lb. (7,700 kg)

## Elevating-Style Seam Welders

Designed to accommodate a wider range of diameters. Clamping fixture, track, carriage, weld process and mandrel are mounted on a hydraulic elevating base to raise and lower the seam welder.

### LWH — Elevating-Style Seam Welder

- For all weldable metals
- For 0.020 to 3/8 inch (0.5 to 10 mm) thickness
- Rack and pinion carriage drive
- Travel accuracy is  $\pm 0.015$  inch (0.4 mm) per 10 feet (3 m)
- Tabletop and mandrel assembly adjusts vertically 48 inches (1,220 mm) to accommodate different diameter parts
- Capable of external welds on cylinders up to 96-inch outside diameter with standard (LWS) tabletop design where all welding is done below tabletop
- With optional combination (LWC) tabletop design parts can be loaded under or around tabletop — capable of external welds on cylinders up to 96-inch outside diameter and internal welds with minimum 55-inch inside diameter
- Frame rides on high-capacity hardened wheels that ride on the structural frame and base that includes the hydraulic lift cylinder
- System is activated by momentary pushbuttons mounted in control box on vertical frame

Consult factory for special part configurations, sizes, shapes, geometry or special applications.

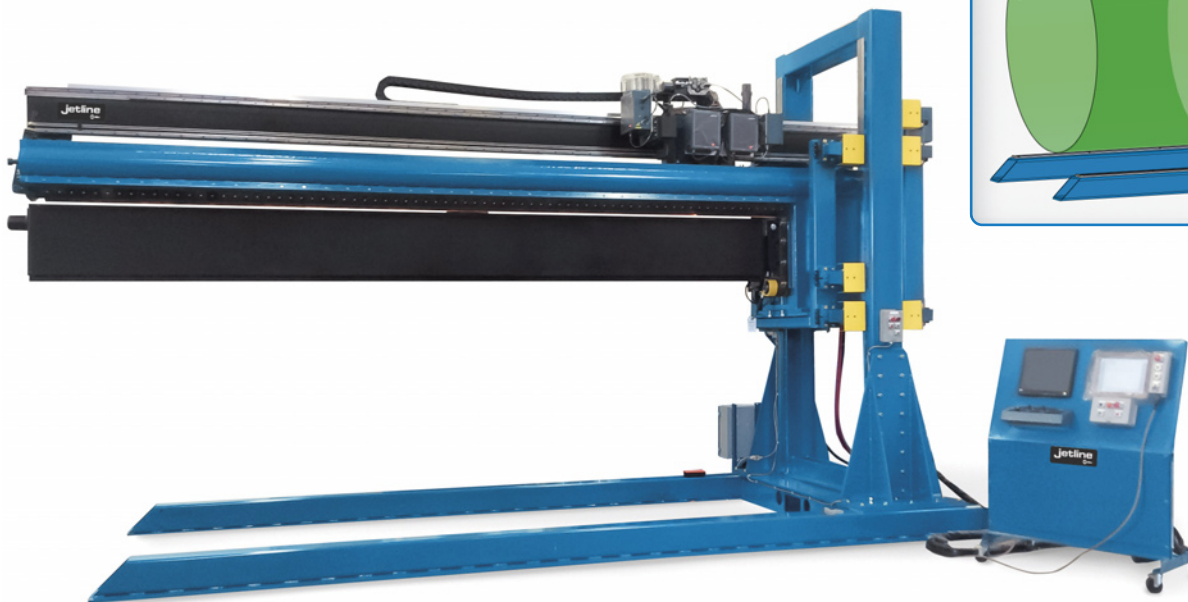
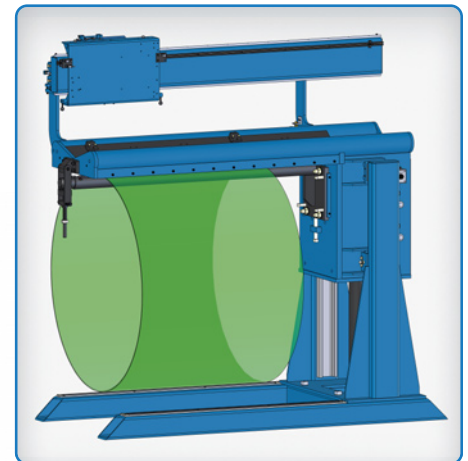
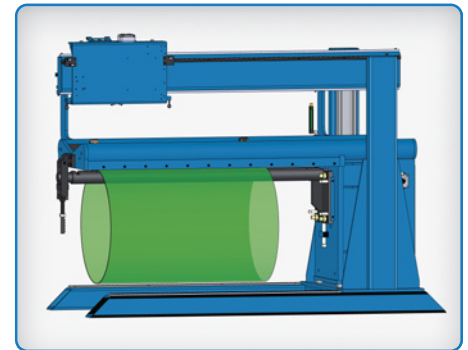

Seam welder shown with OPTIONAL items.

## Specifications (Subject to change without notice.)

Model No.	Welding Length	Minimum Diameter Part	Dimensions (H x W x L)	Approx. Shipping Weight
LWH-72	72 in. (1,830 mm)	6.00 in. (152 mm)	162 x 100 x 192 in. (4,115 x 2,540 x 4,877 mm)	5,400 lb. (2,500 kg)
LWH-84	84 in. (2,135 mm)	6.875 in. (175 mm)	162 x 100 x 204 in. (4,115 x 2,540 x 5,182 mm)	5,950 lb. (2,705 kg)
LWH-96	96 in. (2,440 mm)	7.25 in. (184 mm)	162 x 100 x 216 in. (4,115 x 2,540 x 5,486 mm)	6,500 lb. (2,955 kg)
LWH-120	120 in. (3,050 mm)	9.50 in. (241 mm)	162 x 100 x 240 in. (4,115 x 2,540 x 6,096 mm)	12,100 lb. (5,500 kg)
LWH-144	144 in. (3,660 mm)	12.25 in. (311 mm)	162 x 100 x 264 in. (4,115 x 2,540 x 6,706 mm)	13,200 lb. (6,000 kg)
LWH-168	168 in. (4,270 mm)	15.25 in. (387 mm)	162 x 100 x 288 in. (4,115 x 2,540 x 7,316 mm)	14,300 lb. (6,500 kg)
LWH-192	192 in. (4,875 mm)	18.50 in. (470 mm)	162 x 100 x 312 in. (4,115 x 2,540 x 7,925 mm)	15,400 lb. (7,000 kg)
LWH-216	216 in. (5,485 mm)	21.25 in. (540 mm)	162 x 100 x 336 in. (4,115 x 2,540 x 8,534 mm)	16,500 lb. (7,500 kg)

## Flat Sheet and Internal-Style Seam Welders

Designed for flat sheets and internal welds. Fitted with a sturdy base structure on which the insert holder and back up insert are mounted, instead of the conventional mandrel.

### LWI — Flat Sheet and Internal-Style Seam Welder

- For all weldable metals
- For 0.020 to 3/8 inch (0.5 to 10 mm) thickness
- Rack and pinion carriage drive
- Travel accuracy is  $\pm 0.015$  inch (0.4 mm) per 10 feet (3 m)
- Capable of welds with minimum 55-inch inside diameter — maximum diameter is limited by your material handling capabilities

Consult factory for special part configurations, longer parts or smaller diameter parts.

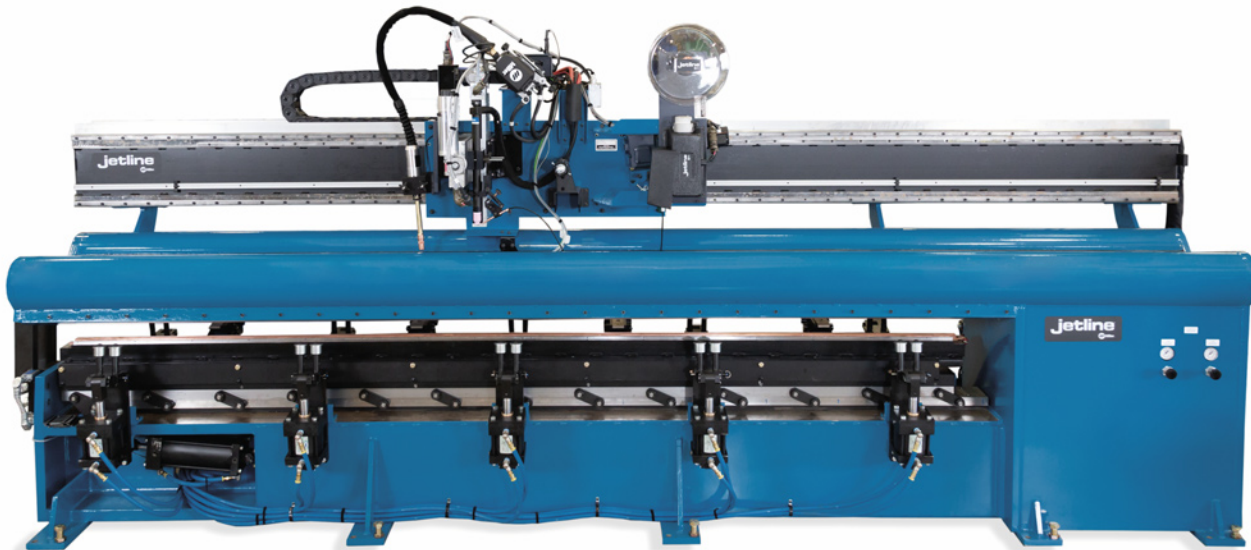
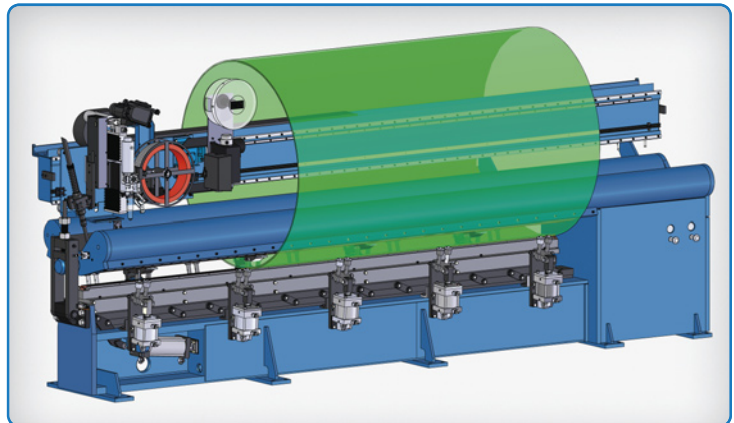

Seam welder shown with OPTIONAL items.

## Specifications (Subject to change without notice.)

Model No.	Welding Length	Minimum Diameter Part	Dimensions (H x W x L)	Approx. Shipping Weight
LWI-72	72 in. (1,830 mm)	55 in. (1,400 mm)	44 x 38 x 146 in. (1,120 x 965 x 3,700 mm)	5,500 lb. (2,500 kg)
LWI-84	84 in. (2,135 mm)	55 in. (1,400 mm)	44 x 38 x 158 in. (1,120 x 965 x 4,000 mm)	6,050 lb. (2,750 kg)
LWI-96	96 in. (2,440 mm)	55 in. (1,400 mm)	44 x 38 x 170 in. (1,120 x 965 x 4,320 mm)	6,600 lb. (3,000 kg)
LWI-120	120 in. (3,050 mm)	55 in. (1,400 mm)	51 x 41 x 194 in. (1,300 x 1,040 x 4,925 mm)	12,200 lb. (5,530 kg)
LWI-144	144 in. (3,660 mm)	55 in. (1,400 mm)	51 x 41 x 218 in. (1,300 x 1,040 x 5,540 mm)	13,300 lb. (6,030 kg)
LWI-168	168 in. (4,270 mm)	55 in. (1,400 mm)	51 x 41 x 242 in. (1,300 x 1,040 x 6,150 mm)	14,400 lb. (6,530 kg)
LWI-192	192 in. (4,875 mm)	60 in. (1,525 mm)	53 x 43 x 266 in. (1,350 x 1,090 x 6,750 mm)	15,500 lb. (7,030 kg)
LWI-216	216 in. (5,485 mm)	60 in. (1,525 mm)	53 x 43 x 290 in. (1,350 x 1,090 x 7,370 mm)	16,600 lb. (7,530 kg)
LWI-240	240 in. (6,100 mm)	60 in. (1,525 mm)	53 x 43 x 314 in. (1,350 x 1,090 x 7,980 mm)	17,700 lb. (8,030 kg)



## Bench-Style Seam Welders

Designed for smaller, shorter applications using a TIG or plasma welding process. Includes a bracket allowing mounting to a work bench or table.

### LWB — Bench-Style Seam Welder

- For all weldable metals
- For 0.020 to 3/16 inch (0.5 to 5 mm) thickness
- Precision linear carriage drive
- Travel accuracy is  $\pm 0.015$  inch (0.4 mm) per 10 feet (3 m)
- Maximum part diameter is determined by the height the seam welder is mounted
- Optional support base is available in place of work bench or table

Consult factory for special part configurations, sizes, shapes, geometry or special applications.

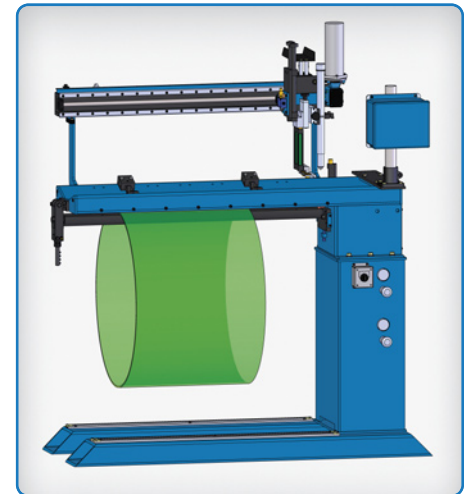

Seam welder shown with OPTIONAL items.

## Specifications (Subject to change without notice.)

Model No.	Welding Length	Minimum Diameter Part	Dimensions (H x W x L)	Approx. Shipping Weight
LWB-6	6 in. (150 mm)	2.625 in. (67 mm)	30 x 24 x 33 in. (760 x 610 x 840 mm)	400 lb. (181 kg)
LWB-12	12 in. (300 mm)	2.625 in. (67 mm)	30 x 24 x 39 in. (760 x 610 x 1,000 mm)	600 lb. (270 kg)
LWB-18	18 in. (450 mm)	2.625 in. (67 mm)	30 x 24 x 45 in. (760 x 610 x 1,150 mm)	900 lb. (410 kg)
LWB-24	24 in. (600 mm)	2.625 in. (67 mm)	30 x 24 x 51 in. (760 x 610 x 1,300 mm)	1,200 lb. (550 kg)
LWB-36	36 in. (900 mm)	3.5 in. (89 mm)	30 x 24 x 63 in. (760 x 610 x 1,600 mm)	1,500 lb. (680 kg)



### 9900 Touch Screen Computer Controller

The Jetline 9900 controller is an industrial touch-screen computer running Windows and a custom Jetline software package. The 9900 uses a simple interface to control the full range of accompanying weld hardware modules. Up to 15 parameters or channels can be simultaneously controlled in closed-loop format. The modular design allows the system to be easily expanded or changed as applications and requirements change. The 9900 can store unlimited weld programs. System parameters and variables are incorporated in the welding programs, offering simplicity and efficiency for basic welding applications or full control of the most demanding ones.



### Remote Operator Station with Optional Video Monitoring

For large diameter or long parts it may be easier to have the operator control the seam welder remotely. Jetline can mount the seam welder controls, video monitoring system and remote controlled motorized slides at a remote operator station. The remote station allows the operator to control the seam welder and view the weld from anywhere nearby. All Jetline seam welders can be supplied with an optional station configured for the customer's needs.



### Arc Length Control

Used with either TIG (GTAW) or plasma arc welding (PAW) process, the Jetline arc length control maintains a constant preset arc length via control of the arc voltage. Arc length controls are compatible with the standard 9700T or the optional 9900 controller.

- Regulation of welding voltage for precise, repeatable procedures.
- Higher weld travel speeds.
- Compensation for electrode erosion.
- Automatic setting of the starting arc gap.



### Motorized Slide

Jetline motorized slide packages simplify welding operation, allowing the operator to position the weld head assembly to a desired location before and during welding for optimal arc performance.



### Cold Wire Feeder

Jetline cold wire feeders are available as an option on all Jetline seam welders using a TIG (GTAW) or plasma arc welding (PAW) process. The wire feeder shown is for use with the standard 9700T controller. The wire drive shown to the right can also be used with the optional 9900 controller.



### Mechanical Oscillator

In arc welding the welder typically weaves the welding arc for various welding requirements. When automating the welding process, weaving or oscillation can still be a desired effect. Oscillating the arc helps with sidewall fusion and eliminates undercut. To meet these welding requirements Jetline offers the JMO 150 and JMO 80 mechanical oscillator systems which can easily be added to an existing weld system or included with new Jetline seam welders. See literature AU/14.0.



### Magnetic Oscillator

Magnetic arc control provides even heat distribution, prevents undercutting, eliminates excessive porosity, ensures sufficient penetration, and evens out the weld puddle. Combined with a magnetic probe, a magnetic field is created around the arc to precisely position, oscillate, and stabilize it. The magnetic arc system bolts onto an existing automatic or semi-automatic welding torch or can also be included on new Jetline seam welders.

## Seam Welder Rebuilds and Retrofits

Jetline offers retrofit and rebuild solutions for matured seam welders. Integrate new Jetline control systems and features into your tired existing seam welder. Jetline can utilize the existing steel of your seam welder and functioning parts and only restore the electrical components and welding equipment that are necessary. A rebuild and retrofit can help resolve operating issues caused by tired equipment and ensures your seam welder will continue to have a long life cycle.



Typical 9700T carriage retrofit package for TIG (GTAW) process

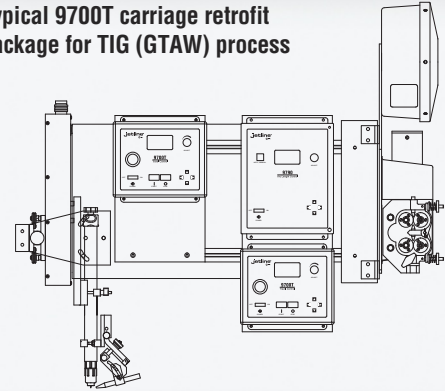

Typical 9700T carriage retrofit package for MIG (GMAW) process

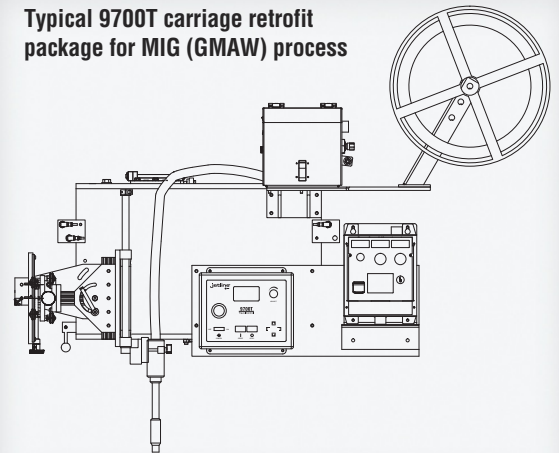

## Seam Welder Styles

Jetline seam welders are available in various styles to accommodate different material types, thicknesses, shapes and sizes, with numerous options and accessories available to maximize production.



*LWS external-style seam welder with shown optional 9900 controller.*

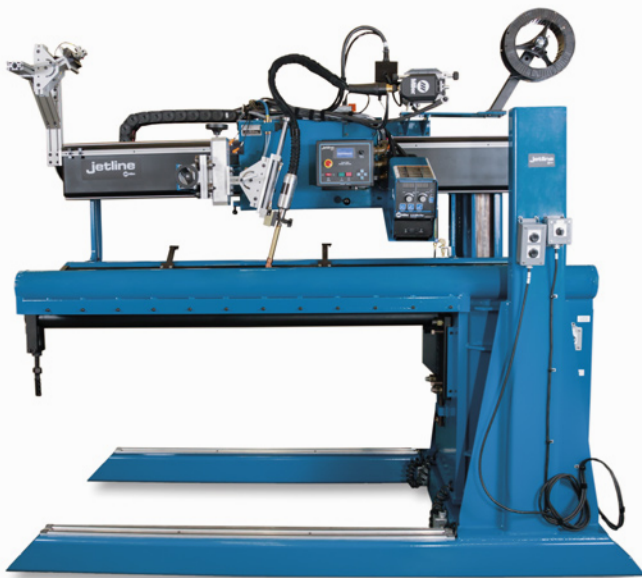

*LWH elevating-style seam welder shown in lowered position.*



*LWH elevating-style seam welder shown in raised position.*

---

Distributed by:

