

OptiDrive™ Systems

**Automated MIG
Welding Systems** 

Quick Specs

Industrial Automation Applications

Contract manufacturing
Automotive components
Recreational vehicles
Farm machinery
Office furniture

Processes

Advanced MIG (GMAW-P)
processes:
Accu-Pulse®
Versa-Pulse™
RMD®
MIG (GMAW)

Wire Diameter and Type

.035 and .045 in.
(0.9/1.2 mm)
steel and stainless
3/64 and 1/16 in.
(1.2/1.6 mm)
4XXX/ 5XXX series
aluminum

Input Power Auto-Line™ 230–575 V
3-phase, 50/60 Hz

Rated Output at 104°F (40°C)
350: 350 A at 31.5 V, 100% duty cycle
500: 500 A at 39 V, 100% duty cycle

Power Source Output Range

350: 20–400 A, 10–44 V
500: 20–600 A, 10–44 V

Introducing OptiDrive, a flexible welding system capable of welding different materials with a minimum of change over time. OptiDrive provides solutions to a variety of challenges in steel, aluminum, and stainless steel.



Better weld quality



Easy to set up and install
for EtherNet/IP™, DeviceNet
or Analog protocols



Easy to add capabilities
for multiple materials



More effective in removing
heat from the torch

Miller recommends



Visit HobartBrothers.com
for your filler metal solutions.



Miller Welding Automation

An ITW Welding Company
281 E. Lies Rd.
Carol Stream, IL 60188 USA

Equipment Sales

Phone: 630-653-6819
Email: MWASales@millerwelds.com

MillerWelds.com



OptiDrive™ and Auto-Continuum™

Combining the Auto-Continuum platform with DINSE pull torch technology delivers all the benefits of OptiDrive.

Moving the drive motor closer to the arc with a DINSE pull torch shortens the distance the wire is pushed to reach the arc. This improves the mechanical response of the feed, and provides more precise wire motion versus a system with a push feeder.

Four drive rolls versus two drive rolls increases the driving surface of the DINSE pull torch further improving the mechanical response of the wire feed and providing more precise wire motion.

Controlling the DINSE pull torch with an Auto-Continuum enables optimized retract starts. The benefits include:

- **Controlled low-spatter arc starts** resulting in maximum consumable life, minimum downtime, and fewer weld defects.
- **Combined arc and feed precision** allows for low spatter, particularly micro spatter, in the toes on aluminum, and provides more consistent bead shape.
- **Flexibility to weld steel, aluminum and stainless** with one flexible capital investment that allows for different materials, filler metals, and weld processes with a minimum of changeover time — now and in the future.

OptiDrive Interface, Auto-Continuum power source and Continuum Cooler stack together seamlessly.



OptiDrive Interface

- Allows for direct control of DINSE pull torch by an Auto-Continuum.
- Stacks conveniently on top of the Auto-Continuum.

Auto-Continuum power source

- Provides 350 or 500 amps at 100 percent duty cycle.
- Communication via Ethernet/IP™, DeviceNet, or Analog.
- Welding processes include Accu-Pulse®, Versa-Pulse™ and RMD® with profile-pulse modification.

Note: See table below for specifics regarding these processes and using OptiDrive Retract Touch Start.

Continuum Cooler

- Space-saving design operates on integrated power — turns on and off with the system.
- Flow and temperature direction protection — protection from overheating.
- Run-on-Demand — pump shuts off after delay when welding stops.

OptiDrive provides a variety of welding-process solutions for multiple materials. Retract Touch Start along with profile-pulse modification, Versa-Pulse, Accu-Pulse and RMD capabilities provide the tools needed for your challenges:

- Superior starts and stops
- Smooth bead spread
- Filling craters
- Reduced etching zone
- Optimized bead appearance

Processes with OptiDrive Retract Touch Start

Wire Size	Material	Wire Type	Process	Gas
.035 in. (0.9 mm)	Steel	E70S-6	MIG	90 Ar / 10 CO ₂
.035 in. (0.9 mm)	Steel	E70S-6	Accu-Pulse	90 Ar / 10 CO ₂
.045 in. (1.2 mm)	Steel	E70S-6	MIG	90 Ar / 10 CO ₂
.045 in. (1.2 mm)	Steel	E70S-6	Accu-Pulse	90 Ar / 10 CO ₂
.035 in. (0.9 mm)	Stainless	308 LSI	MIG	81 Ar / 18 He / 1 CO ₂
.035 in. (0.9 mm)	Stainless	308 LSI	Accu-Pulse	81 Ar / 18 He / 1 CO ₂
.045 in. (1.2 mm)	Stainless	308 LSI	MIG	81 Ar / 18 He / 1 CO ₂
.045 in. (1.2 mm)	Stainless	308 LSI	Accu-Pulse	81 Ar / 18 He / 1 CO ₂
.045 in. (1.2 mm)	Steel	Edge MC	Accu-Pulse	90 Ar / 10 CO ₂
.047 in. (1.2 mm)	Aluminum	4xxx	Accu-Pulse	100 Ar
.047 in. (1.2 mm)	Aluminum	5xxx	Accu-Pulse	100 Ar
.047 in. (1.2 mm)	Aluminum	4943	Accu-Pulse	100 Ar
.062 in. (1.6 mm)	Aluminum	4xxx	Accu-Pulse	100 Ar
.062 in. (1.6 mm)	Aluminum	5xxx	Accu-Pulse	100 Ar
.062 in. (1.6 mm)	Aluminum	4943	Accu-Pulse	100 Ar

OptiDrive™ and DINSE

Miller Welding Automation chose to work with DINSE because we recognize their pull torch as best in class.

Reliable motor drive mechanism is proven in markets globally.

Thermal efficiency to handle the high reflected heat input, particularly in welding aluminum.

Proven designs for over-the-arm and through-arm configurations compatible with a range of robot OEMs.

And a partner in DINSE to deliver retract start by directly controlling their torch with the OptiDrive system.

DINSE water-cooled pull torches offer:

- Superior cooling via a dual circuit — concentric parallel cooling system.
- Best-in-world cooling capacity for extended torch and consumable life.
- Powerful four-drive feed rolls to ensure precise wire control.
- Dedicated gas line which eliminates the potential for atmosphere to enter and mix with the shielding gas.



DINSE WD300 assist feeder

- Assists in wire feed without fighting with the pull torch drive.
- Avoids wire feed issues associated with running different sizes and types of wire.

Note: Optional spool housing set available. See Spare Parts, Wear Items, Torch Consumables and Accessories chart on page 8.

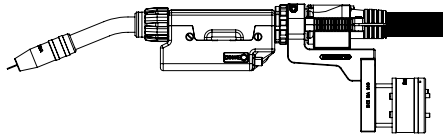

Over-arm straight torch mount

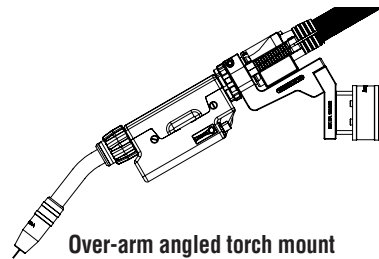

Over-arm angled torch mount

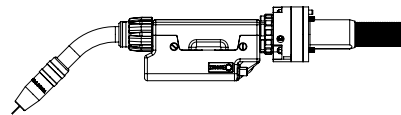

Through-arm torch mount



- Water return
- Water supply
- Liner
- Shielding gas



DINSE water cool schematic

- Shows the unique-to-DINSE cooling design. Cold coolant travels to the torch in several lines, ensuring efficient heat exchange and minimal coolant mixing. Hot coolant travels back to the Continuum Cooler.

OptiDrive™ System Components

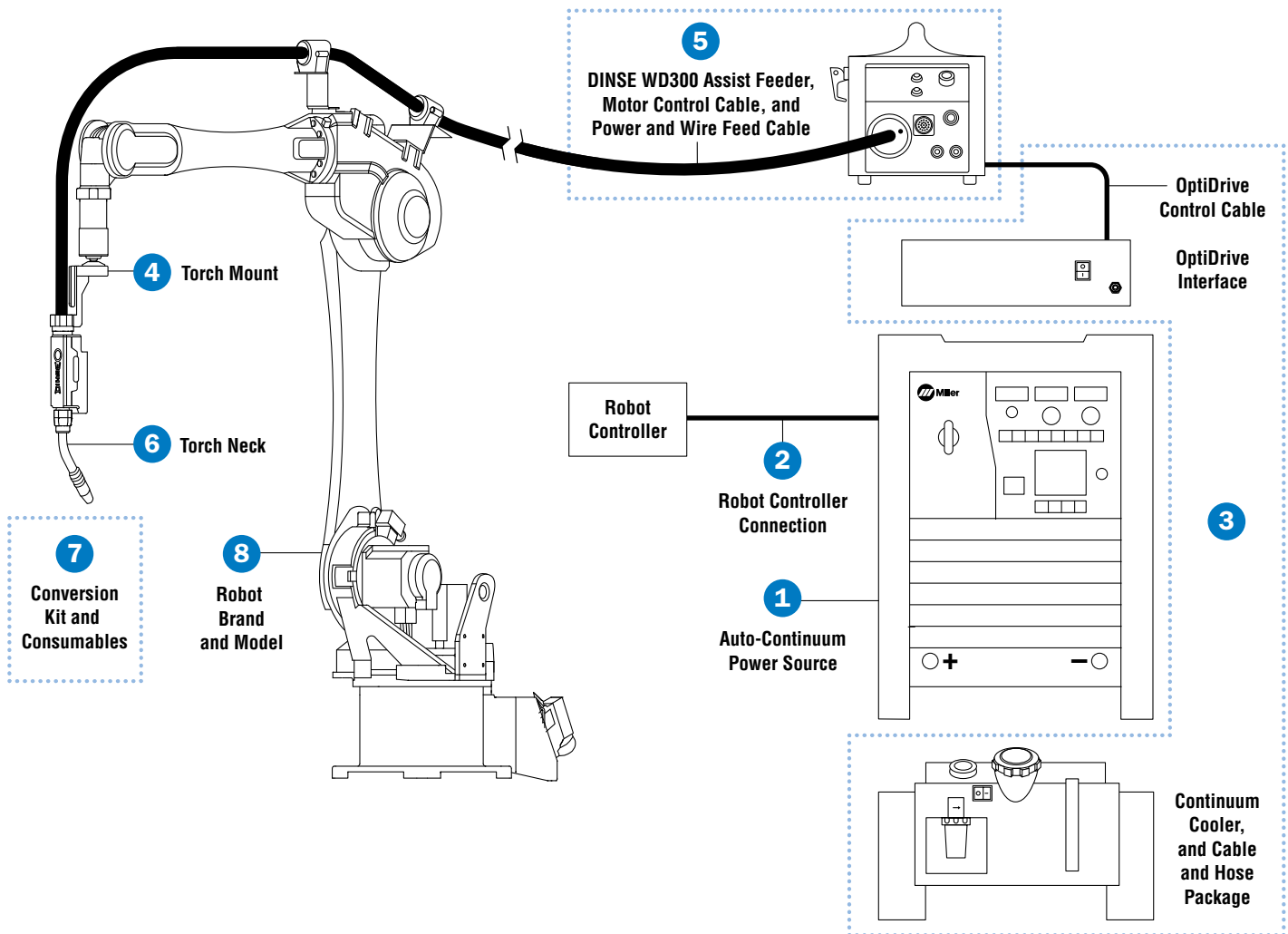

1 Auto-Continuum 350 or 500 Power Source

Choice of power sources rated at either 350 amps or 500 amps at 100-percent duty cycle, with optional auxiliary power.

2 Robot Controller Connection

Options include Ethernet/IP™, DeviceNet or Analog communication between the Auto-Continuum power source and robot.

3 OptiDrive Interface, OptiDrive Control Cable, Continuum Cooler, and Cable and Hose Package

Choose between 9.8- or 32.8-foot (3 or 10 m) cable and hose packages depending on distance required for cooling lines.

4 Torch Mount

Options are available for over-arm and through-arm torch mounts.

5 DINSE WD300 Assist Feeder, Motor Control Cable, and Power and Wire Feed Cable

Options are available for motor control cable length depending on feed distance from the assist feeder.

Note: Also available for cable management or robot dress, are brackets and hardware for various robot brands and models (sold separately). See Cable Support Assemblies chart on page 8.

6 Torch Neck

Options are available for different lengths and bend angles.

7 Conversion Kit and Consumables

Conversion kit includes hardware (liner, drive rolls, feeding components) to convert your OptiDrive to weld your choice of base material and corresponding filler metal and wire diameter. System also includes 10 each of the following torch consumables corresponding to the wire type and size declared for your conversion kit: contact tip, diffuser, nozzle, nozzle insulator and tip adapter.

8 Robot Brand and Model

OptiDrive can be configured to ABB®, FANUC®, Panasonic® and Yaskawa® robot models shown. Contact Miller Welding Automation for other configurations.

Miller Welding Automation recommends working with a robot OEM and/or third-party integrator for communication and programming needs for your OptiDrive.

Configure Your OptiDrive™ System

When configured, your system will be identified by a 12-digit order number.

To configure your custom OptiDrive system, select a single option from each of the eight component sections listed in the table below. List the option identifiers consecutively after the system prefix to create your order number. See sample configuration to the right as an example of how to build a system.

Sample configuration

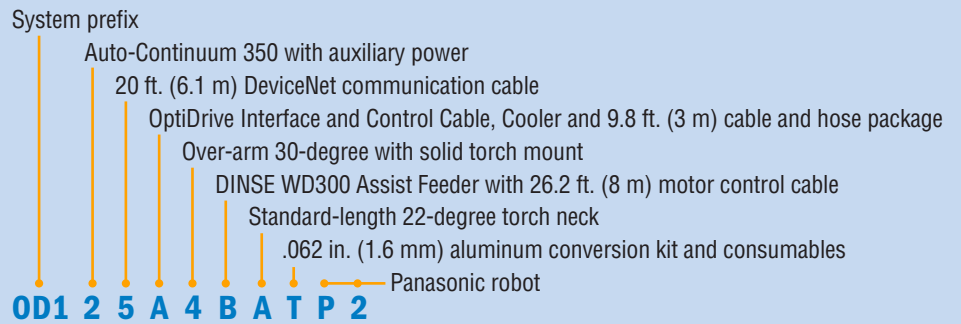

Component	Option	Identifier	Description
1 Power Source	Auto-Continuum 350	1	Power source
		2	Power source with auxiliary power
	Auto-Continuum 500	3	Power source only
		4	Power source with auxiliary power
2 Robot Controller Connection	Ethernet/IP™	1	9.8 ft. (3 m)
		2	32.8 ft. (10 m)
	DeviceNet	5	20 ft. (6.1 m)
	DeviceNet to Analog Adapter	9	Field option. Adapts DeviceNet to analog
3 OptiDrive Interface, OptiDrive Control Cable, Continuum Cooler, and Cable and Hose Package	Cable and Hose Package Length	A	9.8 ft. (3 m) cable and hose package
		B	32.8 ft. (10 m) cable and hose package
4 Torch Mount	Over-Arm	1	Straight with shock sensor
		2	Straight with solid mount
		3	30-degree with shock sensor
		4	30-degree with solid mount
	Through-Arm	5	With shock sensor
		6	Solid mount
5 DINSE WD300 Assist Feeder, Motor Control Cable, and Power and Wire Feed Cable	Motor Control Cable Length	D	9.8 ft. (3 m)
		A	16.4 ft. (5 m)
		B	26.2 ft. (8 m)
6 Torch Neck	Standard Length	A	22-degree bend
		B	45-degree bend
	Long Length	D	22-degree bend
		E	45-degree bend
	Extended Length	F	22-degree bend
		G	45-degree bend
7 Conversion Kit and Consumables	Steel	C	.035 in. (0.9 mm)
		E	.045 in. (1.2 mm)
	Aluminum	S	.047 in. (1.2 mm)
		T	.062 in. (1.6 mm)
8 Robot Brand and Model	ABB®	A1	IRB 1600
		A2	IRB 1600ID, IRB 2600ID-15/1.85, IRB 2600ID-8/2.0
	FANUC®	F1	ARC Mate 100i/C, 100i/C/6L, 120i/C, 120i/C/10L
		F2	ARC Mate 100i/D
	Panasonic®	P1	TM-1100, TM-1400, TM-1600, TM-1800, TM-2000
		P2	TL-1800, TL-2000, HH020L, TA-1000, TA-1400, TA-1600, TA-1800, TA-1900
	Yaskawa®	Y1	AR1440, AR2010

DINSE Water-Cooled Torch Specifications

More specific information on center of mass and schematics is available from DINSE. Contact Miller Welding Automation for other torch configurations.

Over-arm straight torch mount
Mount with standard over-arm torch bracket

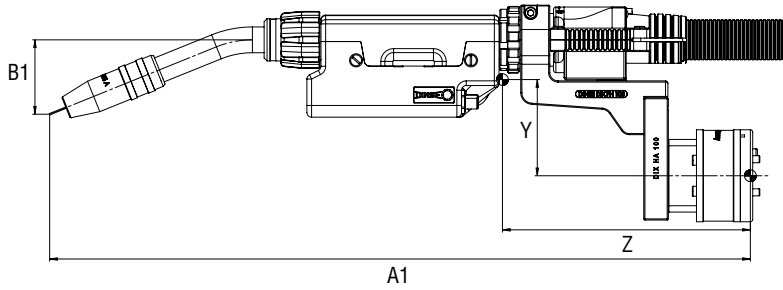

Mount Type	Neck Part Number	Neck Part Name	Angle and Length	A1 (mm)	B1 (mm)	Mass (g)	Y (mm)	Z (mm)
Solid Mount	6390635420	6-3-542 METZ	22 degree, standard	598.1	52.5	4,573.5	82.1	211.6
	6390635403	6-3-542 L METZ	22 degree, long	668.1	52.5	4,704.3	83	224.9
	6390635406	6-3-542 XL METZ	22 degree, extended	748.1	52.5	4,917.1	84.5	244
Shock Sensor	6390635420	6-3-542 METZ	22 degree, standard	598.1	52.5	4,586.7	82.7	210.7
	6390635403	6-3-542 L METZ	22 degree, long	668.1	52.5	4,717.5	83.6	224
	6390635406	6-3-542 XL METZ	22 degree, extended	748.1	52.5	4,930.3	85	243.1

Over-arm angled torch mount
Mount with 30-degree over-arm torch bracket

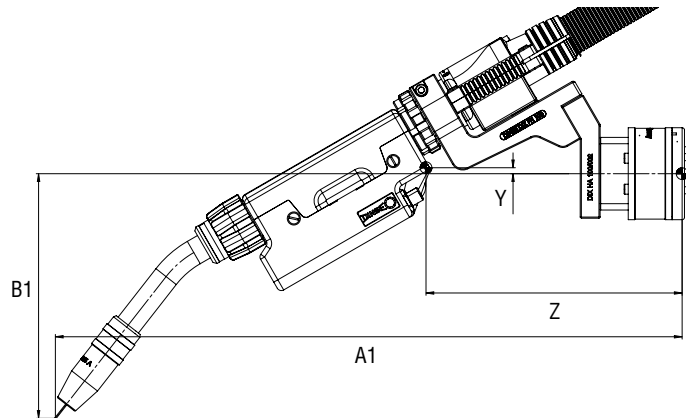

Mount Type	Neck Part Number	Neck Part Name	Angle and Length	A1 (mm)	B1 (mm)	Mass (g)	Y (mm)	Z (mm)
Solid Mount	6390635420	6-3-542 METZ	22 degree, standard	534.9	208.8	4,552.9	5.1	218.6
	6390635403	6-3-542 L METZ	22 degree, long	595.5	243.8	4,683.7	0.6	230.5
	6390635406	6-3-542 XL METZ	22 degree, extended	664.8	283.8	4,896.1	8.7	247.7
Shock Sensor	6390635420	6-3-542 METZ	22 degree, standard	534.9	208.8	4,556.1	5.9	217.7
	6390635403	6-3-542 L METZ	22 degree, long	595.5	243.8	4,696.9	0.2	229.6
	6390635406	6-3-542 XL METZ	22 degree, extended	664.8	283.8	4,909.6	7.9	246.8

Through-arm torch mount
Mount with through-arm torch bracket

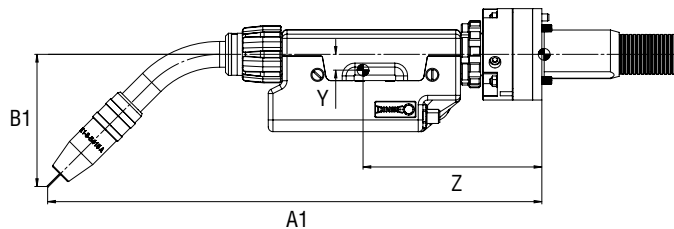

Mount Type	Neck Part Number	Neck Part Name	Angle and Length	A1 (mm)	B1 (mm)	Mass (g)	Y (mm)	Z (mm)
Solid Mount	6390635440	6-3-544 METZ	45 degree, standard	421.8	112.8	3,210.4	-13.5	152.6
	6390635404	6-3-544 L METZ	45 degree, long	491.8	112.8	3,256.9	-13	168.4
	6390635407	6-3-544 XL METZ	45 degree, extended	571.8	112.8	3,469.7	-12.2	189.9
Shock Sensor	6390635440	6-3-544 METZ	45 degree, standard	529.8	112.8	3,806.6	-11.2	217.2
	6390635404	6-3-544 L METZ	45 degree, long	599.8	112.8	3,943.1	-10.8	231.7
	6390635407	6-3-544 XL METZ	45 degree, extended	679.8	112.8	4,155.8	-10.2	251.9

Final Considerations for Your OptiDrive™ System

Conversion kit options can be ordered if your immediate needs require more than one base material, filler metal type or wire diameter. Your initial order will be configured for one option.

Spare parts and wear items can be ordered by part numbers from the conversion kits and consumables charts below and on page 8. Provide these tables to your local distributor for stocking your consumable needs.

Recommended tools for torch changeover and other maintenance can be ordered from the Torch Consumables and Accessories chart on page 8.

OptiDrive™ System Conversion Kits and Consumables

The required **conversion kit** for your OptiDrive system is determined by your filler metal wire, material type and wire diameter needs. See tables below for steel and aluminum conversion kit contents, individual part numbers, and initial stock recommendations.

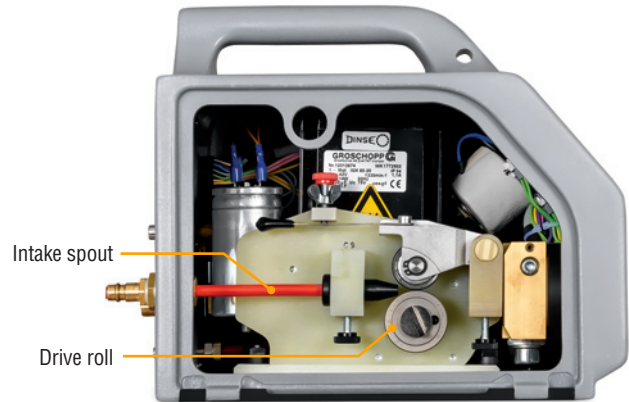
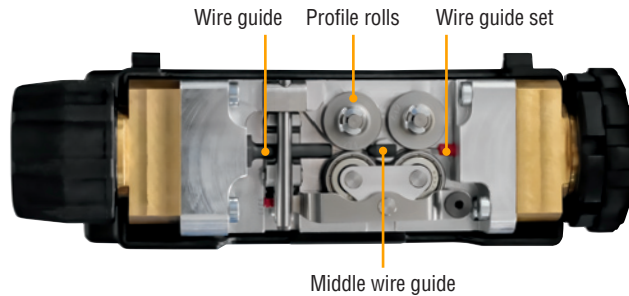

Note: Not shown are the clamping sleeve which holds the liner in place at the back end of the torch, capillary liner located in torch neck, and distance sleeve which protects the lead end of the capillary liner.

Steel wire conversion kits

7430040074 For .035 in. (0.9 mm) steel wire
7430040064 For .045 in. (1.2 mm) steel wire



7430040074 Kit Includes	7430040064 Kit Includes	Part	Part Number	DINSE Part Name	Initial Stock
■	■	Wire guide	7430030049	DIX FD100 WG-AS	10
■	■	Middle wire guide	7430030015	DIX FD100 WG-PS	10
■		Liner 50 ft. (15.5 m)	6130002155	DIX DS 4/1.8-15.5	5
	■	Liner 50 ft. (15.5 m)	6230003155	DIX DS 4/2.2-15.5	5
■	■	WD300 intake spout	629363005	DIX 36-2 WDET	10
■	■	Clamping sleeve	629270270	SH 270	5
■	■	Wire guide set	7430040066	DIX FD200 KF	10
■		Profile roll set .040 in. (1.0 mm)	7430030091	DIX FD100 RS-10 S	2
■		WD300 drive roll .040 in. (1.0 mm)	719042100	DIX DV-04-10/10T	2
	■	Profile roll set .045 in. (1.2 mm)	7430030092	DIX FD100 RS-12 S	5
	■	WD300 drive roll .045 in. (1.2 mm)	719042120	DIX DV-04-12/12T	5

Aluminum wire conversion kits

7430040076 For .047 in. (1.2 mm) aluminum wire
7430040077 For .062 in. (1.6 mm) aluminum wire



7430040076 Kit Includes	7430040077 Kit Includes	Part	Part Number	DINSE Part Name	Initial Stock
■	■	Wire guide	7430030049	DIX FD100 WG-AS	2
■	■	Middle wire guide	7430030015	DIX FD100 WG-PS	2
■	■	Liner 41 ft. (12.5 m)	6230025125	DIX DSK 3-12.5	10
■	■	WD300 intake spout	629363005	DIX 36-2 WDET	2
■	■	Distance sleeve	628100001	DHS300	10
■	■	Clamping sleeve	629270270	SH 270	2
■	■	Wire guide set	7430040066	DIX FD200 KF	2
■		Capillary liner .045 in. (1.2 mm)	623002003	DIX DSK 2-0.3 1.2mm	10
■		Profile roll set .045 in. (1.2 mm)	7430030094	DIX FD100 RS-12 A	2
■		WD300 drive roll .045 in. (1.2 mm)	719041120	DIX DV-04-12/12 A	2
	■	Capillary liner .062 in. (1.6 mm)	6230025030	DIX DSK 2-0.3 1.6mm	10
	■	Profile roll set .062 in. (1.6 mm)	7430030097	DIX FD100 RS-16 A	2
	■	WD300 drive roll .062 in. (1.6 mm)	719041160	DIX DV-04-16/16 A	2

Spare Parts, Wear Items, Torch Consumables and Accessories

Your OptiDrive system includes a set of torch consumables (10 each – nozzle, nozzle insulator, contact tip, contact tip adapter and gas diffuser) corresponding to the wire type and size selected for your conversion kit. After your initial order, spare parts and wear items can be ordered from this table and the conversion kit tables on page 7.

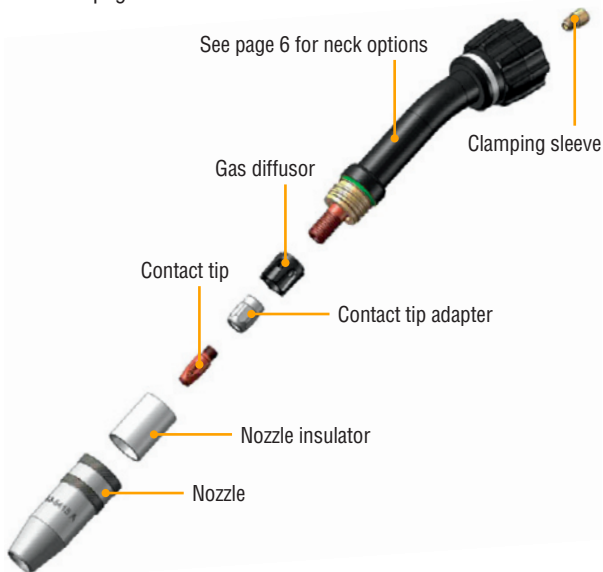

Part	Part Number	Description
Gas Diffuser	6391054000	10-3-540
Nozzle Insulator	6390250000	2-3-500
Nozzles	6390154130	1-3-5413 AID 0 33/64 in. (13 mm) bore, flush
	6390154150	1-3-5415 AID 0 19/32 in. (15 mm) bore, flush
	6390154180	1-3-5418 AID 0 45/64 in. (18 mm) bore, flush
Tip Adaptors	628150008	GS 2-M8
	628150006	DIX GS 2 M6
Contact Tips	629030112	3-2-1.2 M8
	629030116	3-2-1.6 M8
	629030009	3-2-0.9 M6
Clamping Sleeve	629270270	SH270
Spool Housing Set	730530008	DIX WDS 300/001
Hook Spanner	6380160001	For tightening necks and cables
Special Spanner	628010012	For contact tips and tip adapters
Socket Spanner	6380101080	For 3-2-xxxx M8 contact tips
Neck Checking Fixture	685310100	All three required for checking torch necks
Aligning Set	685305210	
Aligning Module	685305100	

Cable Support Assemblies

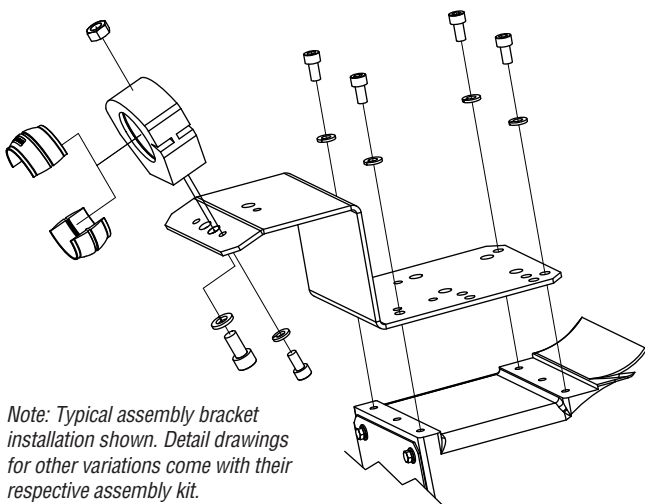

Note: Typical assembly bracket installation shown. Detail drawings for other variations come with their respective assembly kit.

- For ABB® through-arm robots IRB1600 / 1600ID / 2600ID order kit number **P0103M0400_A**.
- For these through-arm models: Yaskawa® AR-1440 / 1730 / 2010, Fanuc® 100iC / 100iD, and Panasonic® TM Series order kit number **P0103M0100_B**.
- More kits are available for Panasonic over-arm configurations. Contact Miller Welding Automation for more information.
- Work with your integrator or installer for more customized solutions with other models.

Contact Us

Miller Welding Automation is your single point of contact for configuring and ordering your OptiDrive system.

Continued technical support can be counted on from Miller Welding Automation in Carol Stream, Illinois. Please call our hotline number: (630) 653-6819.

Spare parts, wear items and torch consumables are provided in your initial purchase of OptiDrive. Use the tables provided to order these items from Miller Welding Automation or your local distributor.

Distributed by:

