

## Guide for Aluminum Welding

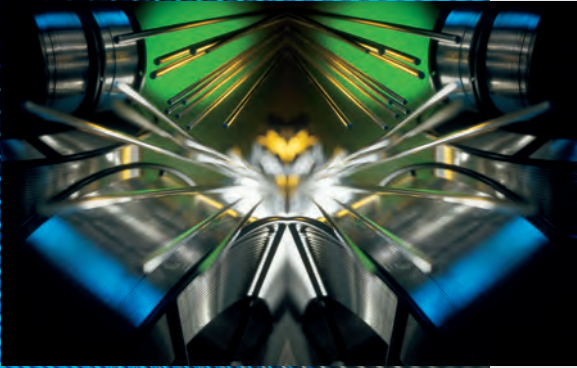

## The Welder's Choice for Quality Aluminum Weld Wire

As a premium filler metal solution, Hobart aluminum wire is supported and manufactured by a team with decades of expertise in aluminum filler metals. It's produced from a state-of-the-art facility, entirely built around aluminum wire production, with custom-built equipment and proprietary processes and production techniques.

Hobart's expertise and customized, innovative manufacturing processes provide aluminum weld wire with excellent soft-start characteristics and minimal burn back. Manual applications achieve a greater weld bead quality. Hobart wire also features superior feedability with reduced bird nesting, extended liner and contact tip life, and excellent x-ray quality.

Hobart has gained recognition in the industry as a premium aluminum filler metal brand with unmatched product quality, reliability and performance. As a part of the ITW Welding North America portfolio, Hobart wire and feeding solutions will be combined with Miller, Bernard, Tregaskiss, and Weldcraft to create the best aluminum welding systems available.

**Technical Assistance: 877-629-2564**

**To Place An Order: 800-424-1543**

\*Hobart Brothers LLC disclaims liability for any injury to persons or to property, or other damages of any nature whatsoever, whether special, indirect, consequential, or compensatory, directly or indirectly resulting from the publication, use of, or reliance on this Guide for Aluminum Welding. Hobart Brothers Company also makes no guarantee or warranty as to the accuracy or completeness of any information published herein.

ITW Welding



It is not merely the innovative manufacturing methods and techniques which make the Hobart product “best in class”. The quality and meticulous attention to detail in every facet of delivering the product into the customer’s hands are also a high priority. It is a well known fact that aluminum requires special procedures to work with and therefore the aluminum welding material must be able to meet all requirements.

The key criteria in the Hobart product are as follows:

- Extreme cleanliness (able to exceed the AWS porosity standard)
- Outstanding feedability
- Superior arc stability
- Superior arc starts
- Excellent welder appeal
- Repeatability and consistency
- Wire diameter control (1/10th of allowed AWS specification)
- All these features available in a wide range of alloys
- Plant and product certifications ISO 9001, AWS, CWB, ABS, ASME, CE, VdTUV and DB

ALLOY	1100	4043	4047	4145	4943	5356	5554	5183	5556
MIG/TIG	Yes	Yes	Yes	Yes	Yes	Yes	Yes	Yes	Yes

The quality does not end here, the product then needs to be packaged and delivered to the customer. To ensure the product arrives in the same condition when it left the factory, great detail has been given to the packaging. Some of the unique features are as follows:

### Spools and Baskets (MIG):

- A sturdy 12” spool double walled reusable box with top entry
- No taping of the box flap due to snug fitting closure
- A sturdy wire basket spool; the strongest in the industry
- Heavy weight plastic bag for better atmospheric protection
- 8” 5 lb., 12” 16 lb. and 22 lb. plastic spools available
- Unique alloy selection guide on side of all boxes (MIG and TIG)

### Straight Lengths (TIG):

- Revolutionary TIG box with zipper style end cap for removal of a few rods then replaced for protection
- Inner liner in TIG box adds to sturdiness, provides snug fit, rods stretch wrapped in bundles eliminates moisture and fretting corrosion
- Master TIG carton holds 4 boxes

### Drums

- 300# drum, 100# drum and 50# ergo pac drum provide tangle free feeding with minimal utilization of dispensing systems
- Multi-sided for extra sturdiness, adapts to most currently available cones
- Double walled with plastic sealable bag between walls for moisture protection
- Unique self contained pallet for maneuverability eliminates use of lifting straps which can damage drums and wire
- Two individual drums per skid

Considering all the above including an extensive range of welding filler metals with the unparalleled technical expertise and services, Hobart Aluminum is the only choice for your aluminum welding solutions.

# Hobart Guide for Aluminum Welding

## General Technical Assistance for Aluminum Design Engineers, Process Engineers & Welders

All commercial welding operations should have a written Welding Procedure Specification (WPS) for each weldment that is produced. This booklet provides guidance in determining the key technical elements required to produce a reliable WPS and achieve a successful welding outcome.

The following uses the flow of a typical Welding Procedure Specification (WPS) as the guideline for its organization, with a sample WPS form shown on page 3.

### Index:

#### Welding Procedure Specification

Page 3 ..... WPS Sample Form

#### Base Metal

Page 4 ..... Alloy and Temper Designations

Page 5 ..... Alloy and Temper Applications

Page 6 ..... Heat Treatable and Non-Heat Treatable Alloys

Page 7 ..... Welded Properties of 5xxx and 6xxx Series Base Metals

#### Filler Metal

Page 8 ..... Guidelines For Selecting the Most Appropriate Filler Metal (4043 or 5356)

Page 9 ..... MAXAL Mig® R4943 and MAXAL Tig® R4943 Guidelines For Elevated Temperature Applications

Page 10 ..... Selecting the Correct Filler Metal to Match Anodized Color Non-Weldable Aluminum Base Metals (Arc Welding)

Page 11 ..... Nominal Compositions of Wrought Alloys and Typical Physical Properties

#### Weld Preparation & Treatments

Page 12 ..... Cleaning the Base Metal before Welding Metal Storage and Weld Joining Preparation - Do's and Don'ts

Page 13 ..... Weld Backing Preheating and Interpass Temperatures Post-Weld Heat Treatment and Age

#### Welding Procedures

Page 14 ..... Electrodes for Aluminum TIG Welding Shielding Gases Used for MIG and TIG Welding

Page 15 ..... MIG and TIG Joint Geometries MIG Equipment Set-Up Parameters

Page 16 ..... Typical MIG Parameters for Groove Welds In Aluminum

Page 17 ..... Typical MIG Parameters for Fillet Welds In Aluminum

Page 18 ..... Typical TIG Parameters for Groove Welds In Aluminum

Page 19 ..... Typical TIG Parameters for Fillet Welds In Aluminum

Page 20 ..... Preferred Mode of Metal Transfer to be Used When MIG Welding Aluminum

Page 21 ..... Pulsed Spray Transfer MIG Welding of Aluminum

#### Problem Solving

Page 22 ..... Obtaining a Stable Arc and Eliminating Erratic Feeding and Burnbacks

Purchasing Contact Tips and Maintenance Suggestions

Page 23 ..... Drive Roll Design and Wire Feedability

Page 24 ..... Weld Joint Porosity

Page 25 ..... Tips for Reducing Weld Joint Porosity

Page 26 ..... Calculation of Dew Point

Page 27 ..... How to Avoid Cracking in Aluminum Alloys

Page 29 ..... Weld Discoloration, Spatter and Black Smut

Page 30 ..... Weld Bead Root Penetration and Fusion

Page 31 ..... Weld Bead Contour and Penetration

Page 32 ..... Solving Weld Profile Problems

Page 33 ..... The Guided Bend Test

Page 34 ..... The Transverse Tension Test

#### Specifications

Page 35 ..... Chemistry Certifications: AWS Classifications

Page 36 ..... American Welding Society Control Documents

#### Information Sources

Page 37 ..... Welding Design Information and Technical Assistance

Page 38 ..... Conversion Tables

#### The MAXAL Commitment

Page 39 ..... Traceability of Electrode and Rod Certifications and Society Approvals Quality of Electrode and Rod Customer Support

Page 40 ..... Advanced Aluminum Welding Technology Seminar

#### Miller Solutions Made for Aluminum

Page 41 ..... Miller Solutions

Page 42 ..... Industrial Aluminum MIG Solutions Industrial Aluminum TIG Solutions

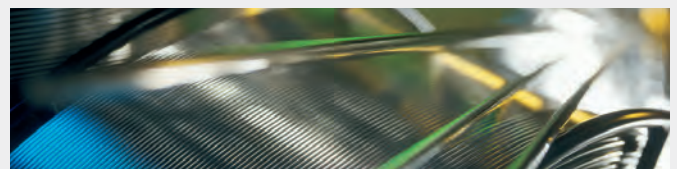

# Welding Procedure Specification

## Specifications

Specification No. \_\_\_\_\_ Date \_\_\_\_\_ Approved \_\_\_\_\_  
Revisions \_\_\_\_\_ Date \_\_\_\_\_ Approved \_\_\_\_\_  
PQR Numbers \_\_\_\_\_  
Certification Specifications & Codes \_\_\_\_\_

## Base Metal

AWS M-No. Alloy Temper Section Thickness  
\_\_\_\_\_/\_\_\_\_\_  
\_\_\_\_\_/\_\_\_\_\_

## Filler Metal

AWS F-No. \_\_\_\_\_ AWS Class \_\_\_\_\_  
Welding wire diameter \_\_\_\_\_  
Welding wire type: MIG \_\_\_\_\_ TIG \_\_\_\_\_

## Weld Preparation & Treatments

### Cleaning:

Oxide removal \_\_\_\_\_  
Hydrocarbon/contaminant removal \_\_\_\_\_  
Etch \_\_\_\_\_ Solvent \_\_\_\_\_ Wash \_\_\_\_\_  
Interpass cleaning: Yes \_\_\_\_\_ No \_\_\_\_\_  
Interpass cleaning method \_\_\_\_\_

### Preheat:

Yes \_\_\_\_\_ No \_\_\_\_\_  
Preheat temperature \_\_\_\_\_  
Interpass temperature limit \_\_\_\_\_

### Backing:

Type \_\_\_\_\_  
Permanent \_\_\_\_\_ Remove \_\_\_\_\_

### Post-Weld Heat Treatment & Age:

Original temper \_\_\_\_\_  
Solution temp. \_\_\_\_\_  
Time at temp. \_\_\_\_\_  
Quench type & temp. \_\_\_\_\_  
Age temp. \_\_\_\_\_  
Age time \_\_\_\_\_

## Welding Procedures

Process: MIG \_\_\_\_\_ TIG \_\_\_\_\_

### Shielding Gas:

Type \_\_\_\_\_ Mixture \_\_\_\_\_  
Flow Rate \_\_\_\_\_ Gas Cup Size \_\_\_\_\_

Weld Description: Groove \_\_\_\_\_ Fillet \_\_\_\_\_

Weld Position: \_\_\_\_\_ Progression: \_\_\_\_\_

### Weld Pass Type:

Stringer \_\_\_\_\_ Weave \_\_\_\_\_  
Oscillation \_\_\_\_\_ Other \_\_\_\_\_

### Back Gouging:

Yes \_\_\_\_\_ No \_\_\_\_\_ Method \_\_\_\_\_

### Welding Pass Data:

Pass no.	Welding process	Amps	Volts	Travel speed
_____	_____	_____	_____	_____
_____	_____	_____	_____	_____
_____	_____	_____	_____	_____
_____	_____	_____	_____	_____

### Welding Sequence Sketch:

### Weld Profile Picture:



The Welder's Choice for  
Quality Aluminum Weld Wire

# Base Metal

## Alloy And Temper Designations

### Aluminum Alloy Compositions - Aluminum Association Numbering System

#### Wrought Alloys

#### Casting Alloys

#### Principal Alloying Elements

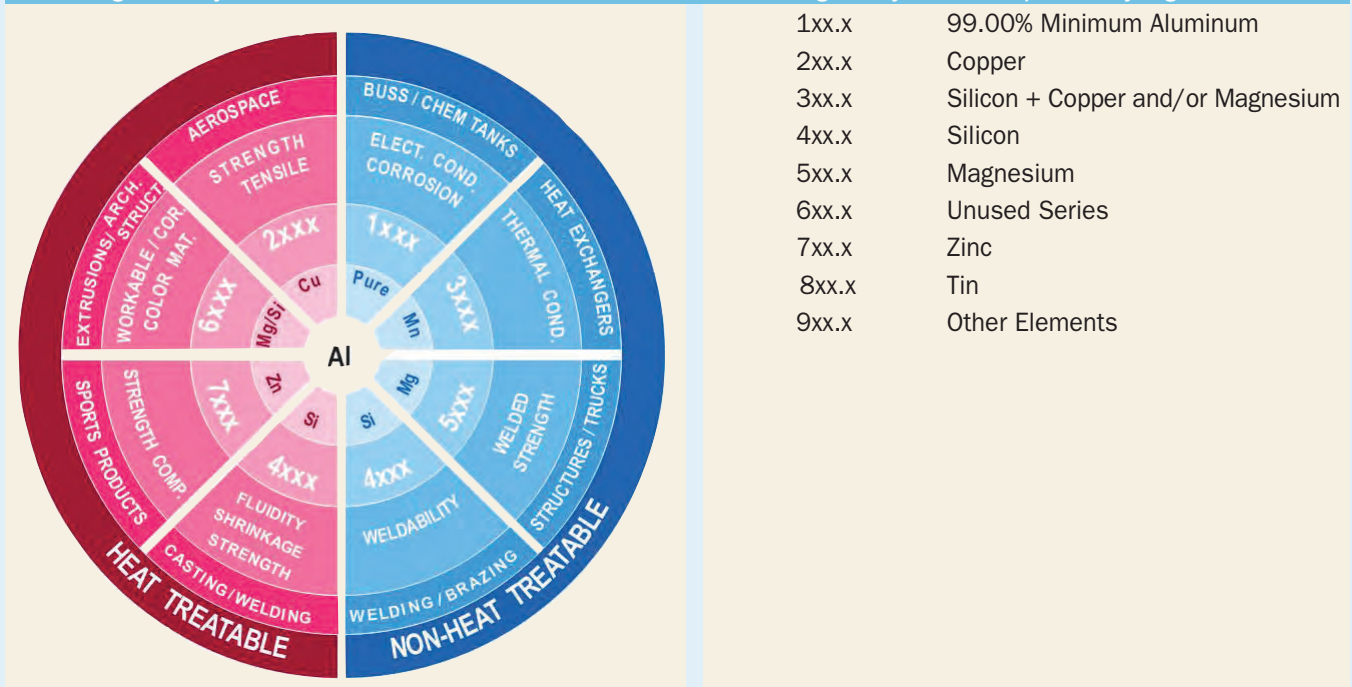

1xx.x	99.00% Minimum Aluminum
2xx.x	Copper
3xx.x	Silicon + Copper and/or Magnesium
4xx.x	Silicon
5xx.x	Magnesium
6xx.x	Unused Series
7xx.x	Zinc
8xx.x	Tin
9xx.x	Other Elements

### Aluminum Alloy Tempers - Aluminum Association Designations

- F	As fabricated
- O	Annealed
- H	Strain hardened
- H1	- Strain hardened only
- H2	- Strain hardened and partially annealed
- H3	- Strain hardened and stabilized
- H4	- Strain hardened and lacquered or painted
- W	Solution heat-treated
- T	Thermally treated
- T1	- Naturally aged after cooling from an elevated temperature shaping process
- T2	- Cold worked after cooling from an elevated temperature shaping process and then naturally aged
- T3	- Solution heat-treated, cold worked, and naturally aged
- T4	- Solution heat-treated and naturally aged
- T5	- Artificially aged after cooling from an elevated temperature shaping process
- T6	- Solution heat-treated and artificially aged
- T7	- Solution heat-treated and stabilized (over aged)
- T8	- Solution heat-treated, cold worked, and artificially aged
- T9	- Solution heat-treated, artificially aged, and cold worked
- T10	- Cold worked after cooling from an elevated temperature shaping process and then artificially aged
- TX51	- Stress relieved by stretching
- TX52	- Stress relieved by compression

# Alloy And Temper Applications

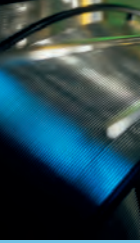

## Most Commonly Used Wrought Aluminum Base Metals

Wrought Alloys	Typical Tempers		Applications and Features
	Non-Heat Treatable	Heat Treatable	
<b>1xxx (pure)</b>			
1350	- F, -O		Electrical bus bars
1100	-O, -H14		Formability (deep drawing etc.), corrosion resistance (chemical tanks)
<b>2xxx (Cu)</b>			
2219	-T6		High strength-to-weight ratio (aerospace), large service temperature range
<b>3xxx (Mn)</b>			
3003	-O, -H12		Formability and high temperature service (heat exchangers, cookware)
<b>5xxx (Mg)</b>			
5052	-O, -H34		Formability, corrosion resistance, and low cost (roll forms, auto, trailers, truck trailer sheeting)
5454	-O, -H34		Elevated temperature applications (wheels)
5086	-H32, -H34		Strength and toughness (shipbuilding, boats)
5083	-H32		High strength, good saltwater corrosion resistance (shipbuilding), cryogenic application
5456	-H32		High strength-to-weight ratio (pressure vessels, tanks)
<b>6xxx (Mg/Si)</b>			
6061	-T6, -T651		High strength and toughness (truck trailer, rail cars)
6063	-T5		Strength and good anodizing properties (architectural applications, automotive trim)
6005			
6009	-T5		Cost efficient extrusions (auto, architectural applications)
6111			
<b>7xxx (Zn)</b>			
7005			Copper-free 7xxx alloys which are good for extrusions.
7021	-T53, -T63		Good toughness and formability. (automotive, truck, ships railings, bumper supports, sports products such as bats, bikes etc.)
7029			
7146			

Note: Alloys 2024, 7075 and 7050 are considered non-weldable by the arc welding process. See page 9.

## Most Commonly Used Cast Aluminum Alloys

Casting Alloys	Typical Tempers		Applications and Features
	Non-Heat Treatable	Heat Treatable	
<b>2xx.x</b>			
201.0			Limited Weldability
206.0			Limited Weldability
224.0			Limited Weldability
<b>3xx.x (Si+Cu and/or Mg)</b>			
319.0		x	Elevated temperature strength (auto pistons)
333.0		x	Elevated temperature strength (diesel pistons)
354.0		x	(auto accessories, crank cases)
C355.0		x	(aircraft, missiles)
A356.0 (356.0)		x	General purpose structural
A357.0		x	High strength (aerospace)
359.0		x	High impact strength (aircraft structural)
380.0	x		General purpose
<b>4xx.x (Si)</b>			
443.0	x		Pressure tight (marine, valves)
A444.0	x		
<b>5xx.x (Mg)</b>			
511.0	x		Good anodizing properties (architectural) (fittings, cooking utensils)
512.0	x		
513.0	x		
514.0	x		Excellent corrosion resistance (chemical processing, marine)
<b>7xx.0 (Zn)</b>			
710.0		x	Good brazing characteristics
712.0		x	(general purpose, corrosion resistant applications)

## Heat Treatable And Non-Heat Treatable Alloys

This section presents a discussion about the properties, before and after welding, of heat treatable vs. non-heat treatable aluminum alloys. This is an area of concern for anyone attempting to choose the best base material alloys and tempers and the correct filler materials to join them. It is in this area that manufacturers have difficulty achieving consistent mechanical properties and defect free weldments in production. For purposes of discussion this section will limit the dialog to a comparison of the 6xxx and 5xxx series alloys:

The 6xxx series base metals have low alloy content and are easy for mill product fabricators to form into extrusions, tubing, forgings and other shaped products and then to heat treat to obtain high mechanical properties, making them economical to produce. The 5xxx series base metals have high alloy content and because of their strain hardening and higher flow stress characteristics are more costly to fabricate into shapes. However the 5xxx series base metals are economically rolled into sheet and plate and roll formed into shapes when specific shapes are desired.

The 6xxx series base metals obtain their maximum mechanical properties through heat treatment and aging. The aluminum metal matrix is strengthened by the precipitation of the alloying elements as intermetallic compounds whose size and distribution throughout the matrix is carefully controlled through precise thermal operations. When the 6xxx series base metals are welded, the microstructure in the HAZ is degraded and the mechanical properties are typically reduced by 30 - 50%. Figure 1 on page 7 shows that 6061 and its most common filler metal 4043 both have a typical annealed tensile strength of around 19 ksi. Depending on the heat input during the welding operation, the base metal can be fully annealed for some distance from the weld, especially in areas being weld repaired.

The 5xxx series base metals obtain their maximum mechanical properties through alloying element solid solution strengthening and additional strength is gained from cold working. The welding operation does not affect the solid solution strengthening of the base metal, only the cold working portion of the strength is lost in the heat affected zone transforming it to the annealed condition. Figure 1 on page 7 shows that the typical annealed tensile strength of 5083 base metal is 43 ksi.

Figure 1 on page 7 compares the loss of strength in the heat affected zone of welded 6061-T6 and 5083-H321 wrought base metals.

Figure 2 on page 7 shows the loss of strength in the heat affected zone of the as-welded 6061-T4 and -T6 base metals compared with post-weld aging.

The chart on page 7 shows the basic alloying elements and typical ultimate tensile strengths in the non-welded and as-welded conditions for the most frequently welded 6xxx and 5xxx series base metals. The charts illustrate and are supported by the following important points:

- 1 The loss of as-welded strength in the 5xxx base metals is significantly less than that of the 6xxx base metals.
- 2 The 6xxx base metal properties shown are dependent on a minimum of 20% dilution of 6xxx base metal into the 4043 filler metal weld pool. The 5xxx base metals when welded with 5xxx filler metals are not dependent on dilution.
- 3 The 6xxx base metals have 30% higher thermal conductivity than the 5xxx base metals making it more difficult to produce consistent quality welds in the 6xxx base metals. Therefore 6xxx base metals require higher heat input to achieve penetration and this can result in increased distortion of the welded structure.
- 4 6xxx base metals welded with 5xxx filler metals are more solidification crack sensitive than 5xxx base metals welded with 5xxx filler-metals. See page 10.
- 5 The as-welded mechanical properties of the 6xxx base metals are very sensitive to welding variables such as heat input and joint design whereas the 5xxx base metals are far less sensitive to these variables, making the 5xxx as-welded results much more controllable.
- 6 As-welded 5xxx base metals welded with 5xxx filler metals have higher ductility, toughness, and crack propagation resistance than as-welded or post-weld heat treated and aged 6xxx base metals welded with 4043.



# Welded Properties Of 5xxx And 6xxx Series Base Metals

Un-welded & welded mechanical properties for the most frequently welded 6xxx & 5xxx series base metals.

**Figure 1**  
 Typical properties of 6061-T6 as welded  
 with three different heat inputs  
 vs.  
 5083-H321 as welded with high or low heat

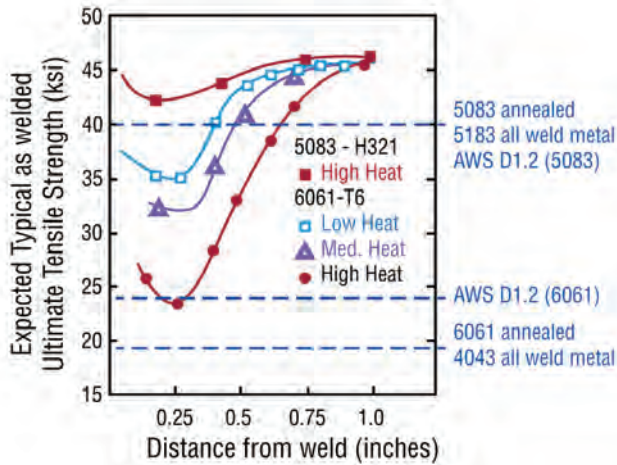

**Figure 2**  
 Typical properties of 6061-T4 & T6

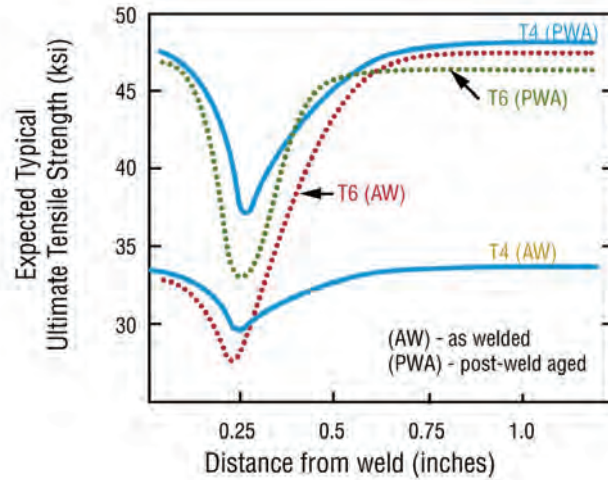

Base Metal & Temper	% Si	% Mg	Typical UTS (non-HAZ) ksi	Typical UTS (welded) ksi	Min. Expected UTS (welded) ksi	Min. Expected UTS (welded) as a % of Typical UTS (non-HAZ) %
<b>Heat Treatable 6xxx Base Metals</b>						
<b>6061</b>						
T6	0.6	1.0	45	27	24	53
T4 (PWA)			45	37	32	71
T6 (PWA)			43	33	27	61
T6 (PWH&A)			45	44	38	84
<b>6063</b>						
T6	0.4	0.7	35	20	17	54
(PWA) - post-weld aged (PWH&A) - post-weld heat treated and aged						
<b>Non-Heat Treatable 5xxx Base Metals</b>						
<b>5052</b>						
H32		2.5	35	28	25	71
H34			38	28	25	66
<b>5454</b>						
H34		2.7	44	35	31	70
<b>5086</b>						
H34		4.0	47	39	35	74
<b>5083</b>						
H116 & H321		5.0	46	43	40	87
<b>5456</b>						
H116		5.1	51	46	42	82

## Guidelines For Selecting The Most Appropriate Filler Metal (4043/4943 or 5356)

Selecting the correct filler alloy for aluminum is based on the operating conditions of the finished welded component. It is therefore essential to have the answers to some basic questions prior to the selection of the most appropriate filler metal.

1. What is the aluminum base metal designation?
2. Will the welded component be exposed to sustained elevated temperature?
3. Will the completed weldment be subjected to post weld anodizing?
4. Will shear strength, ductility, and toughness be of prime consideration?
5. Is post-weld heat treatment to be performed?

Alloys 4043/4943 and 5356 are used in over 85% of all aluminum weldments. If the technical requirements of the weld can be met with either 4043/4943 or 5356, use one of these two alloys because they are readily available and are the least expensive to purchase. Also consider using the largest recommended diameter wire because the larger sizes are also less expensive.

When welding the 5xxx and 6xxx series base metals the following considerations should be made when selecting the most appropriate filler metal:

- For 6xxx series base metals, and 5xxx series base metals containing up to 2.5% (nominal) Magnesium use either 4043/4943 or 5356.
- For 5xxx series base metals containing more than 2.5% (nominal) Magnesium use 5356 filler metal and do not use 4043/4943 filler metal.
- For good anodized color matching use 5356.
- For higher ductility and toughness use 5356. This will increase resistance to crack propagation.
- For long term elevated temperature exposure above 150°F use 5554 or 4043/4943. Do not use 5356.
- For higher shear strength use 5356 or 4943. A rule-of-thumb is that it takes three fillet passes of 4043 to equal the shear strength of one pass of 5356.
- For reduction of termination and shrinkage cracking use 4043/4943 or 4047.
- For reduction of welding distortion use 4043/4943 or 4047.
- For brighter welds with less welding “smut” use 4043/4943.
- For better feedability through the welding gun use 5356. 5356 is twice as stiff as 4043/4943 and therefore feeds better. However, MAXAL’s 4043/4943 has excellent feedability.

Note: For more detailed information on filler metal selection refer to the Hobart selection chart in the back of this book.



## MaxalMig® ER4943 and MaxalTig® R4943

### A 25% increase in tensile + shear strength and 50% increase in yield strength

Alloy 4943 filler metal was designed to provide a high strength solution with the ease of welding and other advantages of 4043. Alloy 4043 filler metal is a popular aluminum/silicon filler alloy for general purpose welding applications. Alloy 4943 filler metal was formulated to be welded with the same weld procedure specifications as 4043 and 4643, and does not depend upon dilution from the base metal during welding to increase the strength of the weld deposit, while maintaining the same excellent corrosion characteristics, low melting temperature, low shrinkage rate, higher fluidity, and low hot cracking sensitivity. Welds exhibit low welding smut and low discoloration. 4943 is heat-treatable and exhibits strength levels superior to 4043 and 4643 in post weld age and post weld heat treat and age conditions.

Testing has shown that 4943 will typically provide 25% improved tensile and shear strength as 50% improved yield strength over 4043 in the as-needed condition.

**Applications:** Current 4043 and 4643 Applications, Welding 1xxx, 3xxx, 4xxx, 5xxx series with up to 2.5% (nominal) Magnesium (Mg) such as 5052 & 6xxx series base metals. (Refer to the Hobart Aluminum filler metal selection chart for further guidance in selecting filler metals for welding specific base metals.)

- Automotive/motorcycle frames
- Aerospace hardware
- Wheels
- Ship decks
- Furniture
- Post weld age, post weld heat treat & age applications
- Sports products - scooters/bicycles
- General repair and maintenance
- Alloy 356 Castings
- Ladders and frames

### Strength Comparison, 4043 vs. 4943 (All weld metal, GMAW, no base metal dilution)

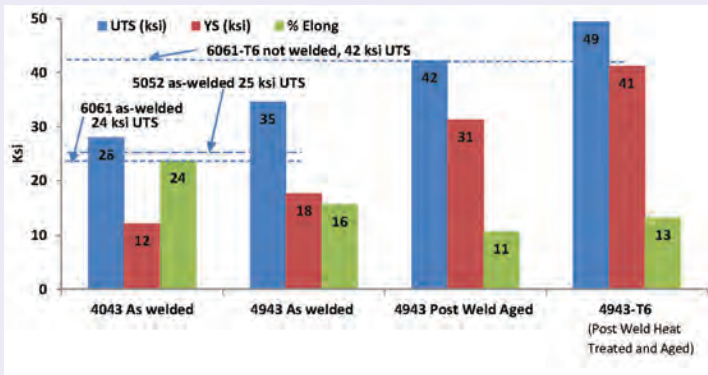

#### Fillet Weld Strength:

The most important benefit of 4943 is to provide consistently higher strength fillet welds. There are far more fillet welds than groove welds used in structural welded components and unlike full penetration groove weld transverse tensile strength, which is controlled by the base metal HAZ, fillet weld shear strength is directly controlled by the strength of the filler metal used during welding. Filler metal shear strength is proportional to filler metal tensile strength. Typical shear strength for 4943 is greater than 15.5 ksi (4043 published value is 11.5 ksi).

### Guidelines For Elevated Temperature Applications

Alcoa research engineers discovered that stress corrosion cracking (SCC) in 5xxx series alloys can be encountered when used in elevated temperature applications. The research and resultant field performance data shows that 5xxx series alloys with magnesium contents above 3% are susceptible to SCC when exposed to prolonged temperatures between 150 and 350 degrees F. With prolonged exposure to these temperatures, precipitates can form in the grain boundaries that are highly anodic to the aluminum-magnesium matrix. It is this continuous grain boundary network of precipitates that produces susceptibility to stress corrosion cracking (SCC) and the potential for premature component failure.

Base metal 5454 was specifically developed by Alcoa for good strength and ductility characteristics when used in elevated temperature applications. Filler metal ER5554 was developed to weld base metal 5454 and both alloys contain magnesium contents between 2.4% and 3.0%. Therefore, both alloys are suitable for elevated temperature applications and are not susceptible to SCC.

Filler metal ER4043 does not have magnesium added to its alloy composition and can be used to weld 5xxx series alloys with up to 2.5% magnesium (nominal) as well as other base metals suitable for elevated temperature applications such as the 1xxx, 3xxx and 6xxx base metals.

## Selecting The Correct Filler Metal To Match Anodized Color

If post-weld anodizing is to be performed it is important to select the correct filler metal to match color with a base metal after anodizing.

The classic example of what NOT to do is to weld 6xxx series base metals with 4xxx filler metals and then anodize the end product. The 6xxx series base metals will anodize bright and clear while the 4xxx filler metals anodize dark and gray in color because of the free silicon content in the 4xxx series alloys. Refer to the list of alloy chemistries on page 10 of this booklet and follow the recommendations in the column for post-anodized color. Also, evaluate the ratings for color match after anodizing in the aluminum filler metal selection chart in the back of this booklet.

## Non-Weldable Aluminum Base Metals (Arc Welding)

Aluminum base metals that are referred to as “non-weldable” are base metals that have an elevated solidification cracking tendency and in some cases have an increased susceptibility to stress corrosion cracking in the as-welded condition. These base metals are unsuitable for arc welding applications.

Some of the base metals that have these tendencies and susceptibilities are as follows:

### **6262 and 2011** (Used for screw machine stock applications.)

These two base metals have lead, bismuth, and/or tin added in small quantities to facilitate machinability. These small additions of low melting point metals seriously increase their solidification cracking tendency. Therefore, these base metals are typically mechanically fastened rather than welded.

### **2xxx series alloys containing, aluminum-copper-magnesium**

(Used for aerospace and other high performance applications.) Examples: 2017 and 2024

These types of base metals can be susceptible to stress corrosion cracking and premature failure if arc welded.

Note: There are other 2xxx series base metals such as 2219 which are aluminum-copper alloys with no magnesium added that are considered weldable.

### **7xxx series alloys, aluminum-zinc-copper-magnesium**

(Used for aerospace and other high performance applications.) Examples: 7075, 7178, 7050, and 7150

These types of base metals can be susceptible to stress corrosion cracking and premature failure if arc welded.

Note: There are other 7xxx series base metals such as 7005 which are aluminum-zinc-magnesium metals with no copper added that are considered weldable.

### **Explanation:**

In the heat affected zone of the non-weldable 2xxx and 7xxx series alloys, low melting point elements are preferentially precipitated into the grain boundaries which lowers and widens the solidification temperature range of the grain boundary. Consequently, when arc welding these types of base metals, the grain boundaries become the last to solidify and can easily crack due to solidification shrinkage stresses. In addition, the difference in galvanic potential between the grain boundaries and the remainder of the grain structure in these alloys is increased, making them more susceptible to stress corrosion cracking. These base metals are typically mechanically fastened rather than arc welded.

Note: Some of these base metals are presently being welded with the friction stir welding (FSW) process, which operates at lower temperatures than arc welding and does not melt the base metal during welding thereby eliminating solidification problems.



# Nominal Compositions Of Wrought Alloys And Typical Physical Properties



Typical Base Metal and Filler Metal Properties													
Alloy	AWS D1.2 Group	Weldability	Cu	Si	Mn	Mg	Zn	Cr	Zr	Melting Range °F	Density lb/in <sup>3</sup>	Post Anodized Color	% Al Min.
ER1100	F21	–	0.12	–	–	–	–	–	–	1190–1215	0.098	Yellow	99.00
2014		C	4.4	0.8	0.8	0.5	–	–	–	945–1180	0.101	Golden	–
2024		C	4.5	–	0.6	1.5	–	–	–	945–1180	0.101	Golden	–
2219 nl	M24	B	6.3	–	0.3	–	–	–	0.17	1010–1190	0.103	Golden	–
3003	M21	A	–	–	1.2	–	–	–	–	1190–1210	0.099	Clear	–
3004	M21	A	–	–	1.1	1.0	–	–	–	1165–1210	0.098	Clear	–
ER4043	F23	–	–	5.0	–	–	–	–	–	1065–1170	0.097	Gray	–
ER4047	F23	–	–	12.0	–	–	–	–	–	1070–1080	0.096	D. Gray	–
ER4643	F23	–	–	4.2	–	0.2	–	–	–	1065–1170	0.097	Gray	–
ER4943	F23	–	–	5.2	–	0.4	–	–	–	1065–1170	0.097	Gray	–
5005	M21	A	–	–	–	0.8	–	–	–	1170–1210	0.098	Clear	–
5050	M21	A	–	–	–	1.4	–	–	–	1155–1205	0.097	White	–
5052	M22	A	–	–	–	2.5	–	0.25	–	1125–1200	0.097	White	–
5083	M25	A	–	–	0.65	4.45	–	0.15	–	1065–1180	0.096	White	–
ER5183	F22	–	–	–	0.75	4.75	–	0.15	–	1075–1180	0.096	White	–
5086	M25	A	–	–	0.45	4.0	–	0.1	–	1085–1185	0.096	White	–
5087		–	–	–	0.90	4.85	–	0.15	0.15	1070–1175	0.096	White	–
ER5356	F22	–	–	–	0.12	5.0	–	0.12	–	1060–1175	0.096	White	–
5454	M22	A	–	–	0.8	2.8	–	0.1	–	1125–1200	0.096	White	–
5456	M25	A	–	–	0.8	5.2	–	0.1	–	1050–1180	0.096	White	–
ER5554	F22	–	–	–	0.75	2.7	–	0.12	–	1115–1195	0.096	White	–
ER5556	F22	–	–	–	0.75	5.1	–	0.12	–	1060–1175	0.096	White	–
6005	M23	A	0.5	0.75	–	0.5	–	–	–	1125–1210	0.097	Clear	–
6061	M23	A	0.25	0.6	–	1.0	–	0.20	–	1080–1205	0.098	Clear	–
6063	M23	A	–	0.4	–	0.7	–	0.20	–	1140–1210	0.097	Clear	–
6070		B	0.27	1.35	0.7	0.85	–	–	–	1050–1200	0.098	Clear	–
7075		C	1.60	–	–	2.5	5.6	0.30	–	890–1175	0.10	Brown	–

All ER-class alloys have a maximum Be content of 0.0003.  
nl – Also contains 0.10% Vanadium

A – Readily weldable

B – Weldable in most applications, requires a qualified welding procedure

C – Limited weldability, caution; consult reference document before welding

Typical Filler Metal Properties						
Alloy	Weld Ductility	Toughness Resistance	Resistance To	Min. Shear Strength		All Filler Metal Weld Typical Ultimate Tensile Strength (ksi)
	(% Elongation)	To Crack Growth	Solidification Cracking	Longitudinal	Transverse	
1100	High (55)	Good	Good	Low (7.5)	Low (7.5)	Low (13)
4043	Low (15)	Low	Very Good	Low (11.5)	Low (15.0)	Low (28)
4047	Low (13)	Low	Excellent	Low (11.5)	Low (15.0)	High (38)
4643	Low (15)	Low	Good	Med. (13.5)	Med. (20.0)	Med. (29)
4943	Low (15)	Low	Very Good	Med. (15.5)	Med. (23.0)	Med. (35)
5087	Good (25)	High	Good	High (20.0)	High (30.0)	High (42)
5183	Good (25)	High	Good	High (18.5)	High (28.0)	High (41)
5356	High (35)	V. High	Good	High (18.0)	High (26.0)	High (38)
5554	High (40)	V. High	Fair	Med. (17.0)	Med. (23.0)	Med. (33)
5556	Good (25)	High	Good	High (20.0)	High (30.0)	High (42)

# Weld Preparation & Treatments

## Cleaning The Base Metal Before Welding

Good cleaning practices are always important when welding aluminum. The level of cleanliness and metal preparation required for welding depends on the level of quality desired in the welds. Suitable preparation prior to welding is important when fabrications are required to meet the weld quality requirements of manufacturing codes such as AWS D1.2.

High quality welds are far more difficult to achieve in aluminum than in steel. Aluminum has a much greater potential to develop quality problems such as lack of fusion, lack of penetration, and porosity, than does steel. The tough oxide surface film on aluminum can create lack of fusion problems and must be controlled. The high thermal conductivity of aluminum can create lack of penetration problems. The high solubility of hydrogen in molten aluminum can create porosity problems and requires that all moisture and hydrocarbons be eliminated before welding. The thickness of the oxide film on aluminum must be controlled and prevented from hydrating due to the presence of excessive moisture.

## Metal Storage And Weld Joint Preparation - Do's And Don'ts

### Storage

- Store all welding wire and base metal in a dry location with a minimum temperature fluctuation. Welding wire should preferably be stored in a dry heated room or cabinet.
- Store metal vertically to minimize moisture condensation and absorption of water contamination between layers.
- Bring all filler and base metal materials into the welding area 24 hours prior to welding to allow them to come to room temperature.
- Keep welding wire covered at all times.

### Joint Preparation

- Don't use methods that leave a ground or smeared surface. For example, a circular sawed surface is weldable while a band sawed surface leaves a smeared surface that may result in lack of fusion and should be filed to remove smeared metal prior to welding. Using a coarse disc grinder is preferable to a wheel grinder, however, if possible avoid the use of any type of grinder.
- Don't use any lubricants in the joint preparation metal working process, if possible.
- Don't use chlorinated solvents in the welding area because they may form toxic gases in the presence of electric welding arcs.
- Don't use oxyfuel gas cutting, carbon arc cutting or gouging processes, or oxyfuel flames to preheat. These processes damage the heat affected area and promote the growth and hydration of the oxide film present on the surface.
- Use plasma arc cutting & gouging and laser cutting.
- Mechanically remove the plasma arc and laser cut edges from 2xxx, 6xxx and 7xxx series alloys. The melted edges of these alloys will contain detrimental solidification cracks and heat affected zone conditions. Remove a minimum of 1/8 inch of metal from the cut edge. Use mechanical metal removal methods that cut and remove metal chips.
- Prepare and clean the joint prior to assembly. Degrease the surfaces with a solvent.
- Use clean cloth such as cheese cloth or paper towels to solvent clean and dry a welding joint.
- Don't use shop rags to clean welding joints and do not use compressed air to blow off the joint. Compressed air contains moisture and oil contaminates.
- Stainless steel wire brush the joint only after solvent cleaning. Wire brushing prior to cleaning embeds hydrocarbons and other contaminates in the metal surface.
- Stainless steel wire brush all metal that has been etched. The by-product residuals from etching must be removed prior to welding.
- Clean all wire brushes and cutting tools frequently.

## Weld Backing

Temporary backing strips are usually made from copper, anodized aluminum, stainless steel, or various ceramic materials. They are used to control penetration and are removed after welding. Care must be taken to prevent melting the backing material into the weld puddle.

Permanent backing strips are always made from the same alloy as the base metal being welded. Refer to AWS D1.2 for backing strip removal requirements.

Typically no root opening is used when using temporary backing material. A root opening is typically used when using permanent backing material.

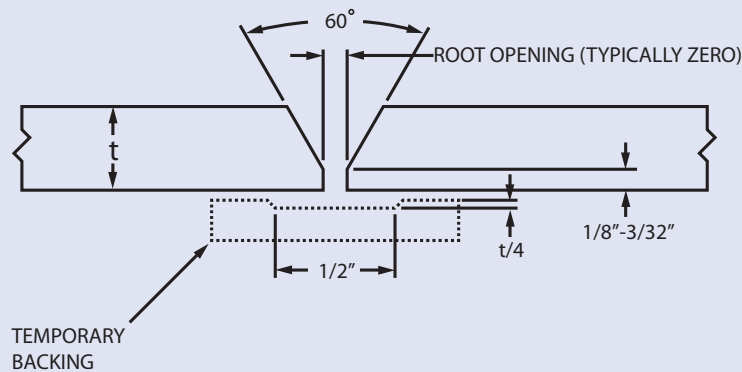

## Preheating And Interpass Temperatures

Preheating can be used to reduce the thermal effects of section size when welding base metals of dissimilar thicknesses. Heat treatable base metals and 5xxx base metals containing more than 3% Mg should not be subjected to preheating and interpass temperatures above 250° F (121° C) for more than 15 minutes. Refer to AWS D1.2.

## Post-Weld Heat Treatment And Age

When heat treatable aluminum alloys are welded, they lose a significant amount of their mechanical properties in the heat affected zone. If the base metal being welded is in the -T4 temper, much of the original strength can be recovered after welding by post-weld aging. If the base metal is welded in the -T6 temper it can be solution heat treated and aged after welding which will restore it to the -T6 temper. Depending on which filler metal is used for welding, post-weld heat treating and aging may cause problems. If the filler metal does not respond to heat treatment and aging the same way as the base metal, the weld joint may exhibit mechanical properties below those of the base metal. Due to stress concentrations in the weld itself, this is not a desirable condition. Therefore, if post-weld heat treatment and aging are performed, the filler metal selected is critical. Contact Hobart and get metallurgical advice on which filler metals are best suited for your application.

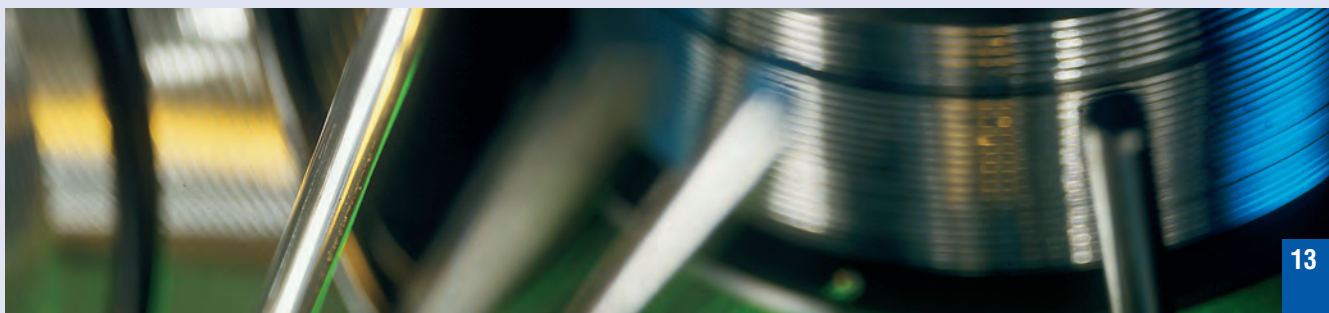

# Welding Procedures

## Electrodes For Aluminum TIG Welding

Tungsten electrodes as specified in AWS A5.12

Pure Tungsten (green)	Most commonly used, least expensive, low current capacity.
Thoriated (1% yellow, 2% red)	Recommended for DC welding, difficult to ball tip, high current carrying capacity, good arc starting, resistant to contamination, slightly radioactive.
Zirconiated (brown)	Commonly used and recommended for AC welding with the properties of both pure and thoriated but not radioactive.
Ceriated (gray)	Similar to the physical properties of thoriated but less problems for AC welding and not radioactive. Point stays sharp with inverter on AC.
Lanthanated (black)	Similar to the physical properties of thoriated but fewer problems for AC welding and not radioactive. Point stays sharp with inverter on AC.

Note: The electrode tip for pure and zirconiated is usually formed into a smooth hemisphere. The 2% Ceriated and 1 1/2 % Lanthanated Tungsten Electrodes have become the most popular for aluminum welding. These electrodes are ground to a blunt point, making sure to keep the grinding direction parallel to the length of the electrode.

## Shielding Gases Used For MIG And TIG Welding

MIG: 100% Argon – most commonly used

75% Helium & 25% Argon – Mixture used when deeper root penetration and reduced porosity are desired.

TIG: 100% Argon – most commonly used

25% Helium & 75% Argon – Mixture used when deeper root penetration and reduced porosity are desired.

Warning: Helium content greater than 25% may cause arc instability, when TIG welding.

Pure argon is the most commonly used shielding gas. It is economical, has good arc cleaning properties, and produces a clean weld. Argon is heavier than air and gives excellent shielding gas coverage in the flat position. The addition of helium increases the ionization potential and the thermal conductivity of the shielding gas which produces greater heat conducted to the base metal through the arc. This feature causes an increase in weld penetration, an increased width of the weld root, and reduced porosity in the weld bead. The negatives of argon-helium gas mixtures are higher required flow rates because of the lower density of the gas and increased cost. Helium also increases weld discoloration because more magnesium is burned in the arc at the higher arc temperatures. The argon gas shall have a minimum purity of 99.997% and a dew point of -76 degrees F or lower. Helium shall have a purity of 99.995 % and a dew point of -71 degrees F or lower.

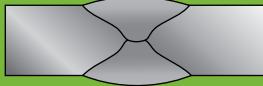
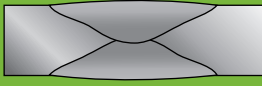
	Argon	Helium
		
Penetration	deep / narrow	wider / hotter
Mechanical properties	less affected	more affected
Welding travel speed	slower	faster
Weld appearance	rippled	smoother
Cleaning action	more	less
Weld appearance (color and smut)	brighter / cleaner	more smut
Arc stability	stable	less stable
Porosity	more	less



## MIG And TIG Joint Geometries

The drawings below illustrate typical joint geometries:

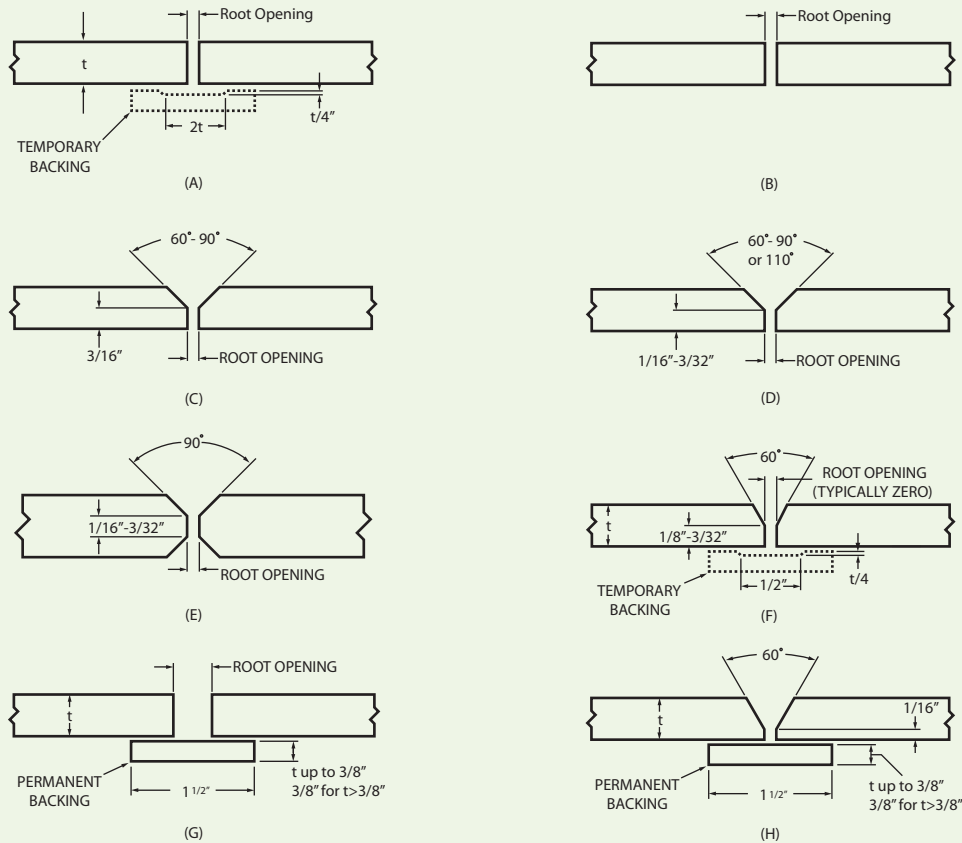

## MIG Equipment Set-Up Parameters

The chart below provides approximate welding parameters as a starting point only. Qualified welding procedures utilizing tested practices should be developed for actual production weldments.

Wire Diameter Inches	Base Material Thickness Inches	Amps 4xxx	Amps 5xxx	Volts 4xxx	Volts 5xxx	Wire Feed Speed (ipm)	
						4xxx	5xxx
0.030	1/16"	90	100	20	18	260	300
	3/32"	110	120	22	21	350	400
	1/8"	130	140	23	21	450	500
	3/16"	150	160	24	22	550	600
	1/4"	175	185	24	22	650	700
0.035	1/16"	90	100	23	21	300	350
	1/8"	130	140	24	22	400	450
	1/4"	170	180	25	23	500	600
3/64"	3/32"	110	120	25	24	170	220
	1/8"	150	160	26	25	270	330
	1/4"	190	220	26	25	320	370
	3/8"	220	230	27	25	390	450
1/16"	1/4"	200	210	26	24	170	200
	3/8"	230	240	27	25	200	230
	1/2"	260	270	28	26	240	270
	3/4"	280	290	29	27	260	300
	1.00"	300	310	30	28	280	320

## Typical MIG Parameters For Groove Welds In Aluminum

Metal Thickness (inches)	Weld Position <sup>1</sup>	Edge Preparation <sup>2</sup>	Joint Spacing (inches)	Weld Passes	Electrode Diameter (inches)	DC (EP) <sup>3</sup> (amps)	Arc Voltage <sup>3</sup> (volts)	Argon Gas Flow (cfh)	Arc Travel Speed (ipm/pass)	Approx. Electrode Consump. (lb/100ft)
1/16	F	A	None	1	.030	70-110	15-20	25	25-45	1.5
	F	G	3/32	1	.030	70-110	15-20	25	25-45	2
3/32	F	A	None	1	.030-3/64	90-150	18-22	30	25-45	1.8
	F,V,H,O	G	1/8	1	.030	110-130	18-23	30	23-30	2
1/8	F,V,H	A	0-3/32	1	.030-3/64	120-150	20-24	30	24-30	2
	F,V,H,O	G	3/16	1	.030-3/64	110-135	19-23	30	18-28	3
3/16	F,V,H	B	0-1/16	1F,1R	.030-3/64	130-175	23-26	35	24-30	4
	F,V,H	F	0-1/16	1	3/64	140-180	23-27	35	24-30	5
	O	F	0-1/16	2F	3/64	140-175	23-27	60	24-30	5
	F,V	H	3/32-3/16	2	3/64-1/16	140-185	23-27	35	24-30	8
	H,O	H	3/16	3	3/64	130-175	23-27	60	25-35	10
1/4	F	B	0-3/32	1F,1R	3/64-1/16	175-200	24-28	40	24-30	6
	F	F	0-3/32	2	3/64-1/16	185-225	24-29	40	24-30	8
	V,H	F	0-3/32	3F,1R	3/64	165-190	25-29	45	25-35	10
	O	F	0-3/32	3F,1R	3/64-1/16	180-200	25-29	60	25-35	10
	F,V	H	1/8-1/4	2-3	3/64-1/16	175-225	25-29	40	24-30	12
	O,H	H	1/4	4-6	3/64-1/16	170-200	25-29	60	25-40	12
3/8	F	C-90°	0-3/32	1F,1R	1/16	225-290	26-29	50	20-30	16
	F	F	0-3/32	2F,1R	1/16	210-275	26-29	50	24-35	18
	V,H	F	0-3/32	3F,1R	1/16	190-220	26-29	55	24-30	20
	O	F	0-3/32	5F,1R	1/16	200-250	26-29	80	25-40	20
	F,V	H	1/4-3/8	4	1/16	210-290	26-29	50	24-30	35
	O,H	H	3/8	8-10	1/16	190-260	26-29	80	25-40	50
3/4	F	C-60°	0-3/32	3F,1R	3/32	340-400	26-31	60	14-20	50
	F	F	0-1/8	4F,1R	3/32	325-375	26-31	60	16-20	70
	V,H,O	F	0-1/16	8F,1R	1/16	240-300	26-30	80	24-30	75
	F	E	0-1/16	3F,3R	1/16	270-330	26-30	60	16-24	70
	V,H,O	E	0-1/16	6F,6R	1/16	230-280	26-30	80	16-24	75

1 F = Flat; V = Vertical; H = Horizontal; O = Overhead.

2 See joint designs on page 14.

3 For 5xxx series electrodes use a welding current in the high side of the range and an arc voltage in the lower portion of the range.

1xxx, 2xxx, and 4xxx series electrodes would use the lower currents and higher arc voltages.

## Typical MIG Parameters For Fillet Welds In Aluminum

Metal Thickness <sup>1</sup> (inches)	Weld Position <sup>2</sup>	Weld Passes <sup>3</sup>	Electrode Diameter (inches)	DC, (EP) <sup>4</sup> (amps)	Arc Voltage <sup>4</sup> (volts)	Argon Gas Flow (cfh)	Arc Travel Speed (ipm/pass)	Approximate Electrode Consumption <sup>3</sup> (lb/100ft)
3/32	F,V,H,O	1	0.030	100-130	18-22	30	24-30	0.75
1/8	F	1	0.030-3/64	125-150	20-24	30	24-30	1
	V,H	1	0.030	110-130	19-23	30	24-30	1
	O	1	0.030-3/64	115-140	20-24	40	24-30	1
3/16	F	1	3/64	180-210	22-26	30	24-30	2.3
	V,H	1	0.030-3/64	130-175	21-25	35	24-30	2.3
	O	1	0.030-3/64	130-190	22-26	45	24-30	2.3
1/4	F	1	3/64-1/16	170-240	24-28	40	24-30	4
	V,H	1	3/64	170-210	23-27	45	24-30	4
	O	1	3/64-1/16	190-220	24-28	60	24-30	4
3/8	F	1	1/16	240-300	26-29	50	18-25	9
	H,V	3	1/16	190-240	24-27	60	24-30	9
	O	3	1/16	200-240	25-28	85	24-30	9
3/4	F	4	3/32	360-380	26-30	60	18-25	36
	H,V	4-6	1/16	260-310	25-29	70	24-30	36
	O	10	1/16	275-310	25-29	85	24-30	36

1. Metal thickness of 3/4 in. or greater for fillet welds sometimes employs a double bevel of 50 degrees or greater included angle with 3/32 to 1/8 in. land thickness on the abutting member.
2. F = Flat; V = Vertical; H = Horizontal; O = Overhead.
3. Number of weld passes and electrode consumption given for weld on one side only.
4. For 5xxx series electrodes use a welding current in the high side of the range given and an arc voltage in the lower portion of the range. 1xxx, 2xxx and 4xxx series electrodes would use the lower currents and higher arc voltages. These considerations constitute a basis for the filler metal groupings in AWS D1.2: F22 (5XXX), F23 (most 4XXX), F24, F25.

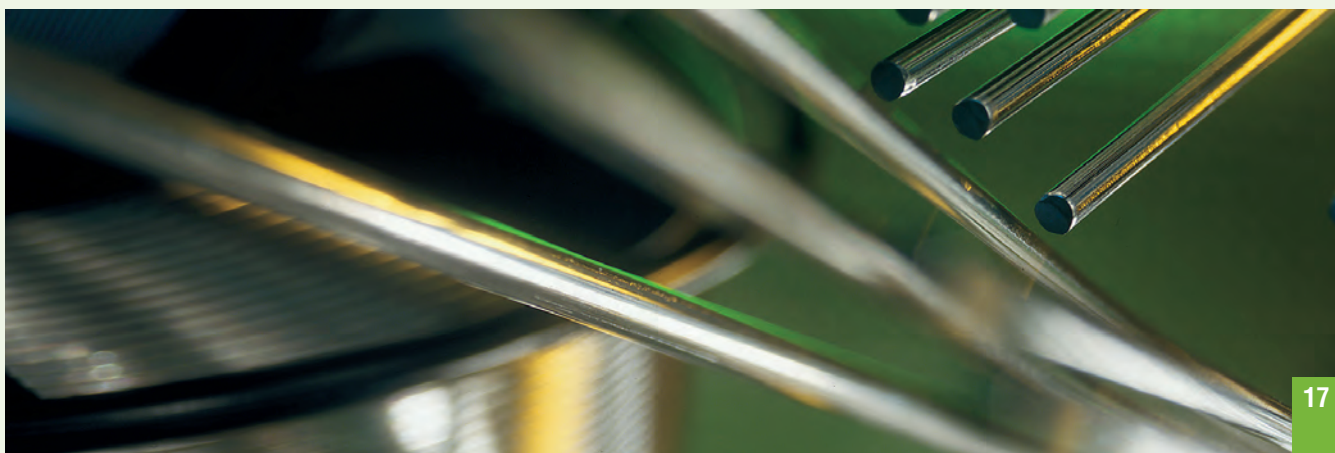

## Typical TIG Parameters For Groove Welds In Aluminum

Aluminum Thickness (inches)	Weld Position <sup>2</sup>	Edge Prep. <sup>3</sup>	Root Opening (inches)	Preheat (°F) <sup>4</sup>	Weld Passes	Filler Diameter (inches)	Tungsten Electrode Diameter (inches)	Gas Cup Inside Diameter (inches)	Argon (cfh)	AC (amps)	Arc Travel Speed (ipm)	Approx. Filler Rod Consumption (lb./100 ft)
1/16	F, V, H	A or B	0-1/16	None	1	3/32	1/16-3/32	3/8	20	70-100	8-10	0.5
	O	A or B	0-1/16	None	1	3/32	1/16	3/8	25	60-75	8-10	0.5
3/32	F	A or B	0-3/32	None	1	1/8	3/32-1/8	3/8	20	95-115	8-10	1
	V, H	A or B	0-3/32	None	1	3/32-1/8	3/32	3/8	20	85-110	8-10	1
	O	A or B	0-3/32	None	1	3/32-1/8	3/32-1/8	3/8	25	90-110	8-10	1
1/8	F	A or B	0-1/8	None	1-2	1/8-5/32	1/8	7/16	20	125-150	10-12	2
	V, H	A or B	0-3/32	None	1-2	1/8	1/8	7/16	20	110-140	10	2
	O	A or B	0-3/32	None	1-2	1/8-5/32	1/8	7/16	25	115-140	10-12	2
3/16 4.5	F	D-60°	0-1/8	None	2	5/32-3/16	5/32-3/16	7/16-1/2	25		170-190	10-12
	V	D-60°	0-3/32	None	2	5/32	5/32	7/16	25	160-175	10-12	4.5
	H	D-90°	0-3/32	None	2	5/32	5/32	7/16	25	155-170	10-12	5
	O	D-110°	0-3/32	None	2	5/32	5/32	7/16	30	165-180	10-12	6
1/4	F	D-60°	0-1/8	None	2	3/16	3/16-1/4	1/2	30	220-275	8-10	8
	V	D-60°	0-3/32	None	2	3/16	3/16	1/2	30	200-240	8-10	8
	H	D-90°	0-3/32	None	2-3	5/32-3/16	5/32-3/16	1/2	30	190-225	8-10	9
	O	D-110°	0-3/32	None	2	3/16	3/16	1/2	30	210-250	8-10	10
3/8	F	D-60°	0-1/8	Optional up to 250°F Max.	2	3/16-1/4	1/4	5/8	35	315-375	8-10	15.5
	F	E	0-3/32		2	3/16-1/4	1/4	5/8	35	340-380	8-10	14
	V	D-60°	0-3/32		3	3/16	3/16-1/4	5/8	35	260-300	8-10	19
	V, H, O	E	0-3/32		2	3/16	3/16-1/4	5/8	35	240-300	8-10	17
	H	D-90°	0-3/32		3	3/16	3/16-1/4	5/8	35	240-300	8-10	22
	O	D-110°	0-3/32		3	3/16	3/16-1/4	5/8	40	260-300	8-10	32

- 1 See also "Recommended Practices for Gas Shielded-Arc Welding of Aluminum and Aluminum Alloy Pipe," AWS D10.7.
- 2 F=Flat; V=Vertical; H=Horizontal; O=Overhead.
- 3 See joint designs on page 15.
- 4 Preheating at excessive temperatures or for extended periods of time will reduce weld strength. This is particularly true for base metals in heat-treated tempers.

## Typical TIG Parameters For Fillet Welds In Aluminum

Aluminum Thickness (inches)	Weld Position <sup>1</sup>	Preheat (°F) <sup>2</sup>	Weld Passes <sup>3</sup>	Filler Diameter (inches)	Tungsten Electrode Diameter (inches)	Gas Cup Inside Diameter (inches)	Argon Flow (cfh)	AC (amps)	Arc Travel Speed (ipm)	Approx. Filler Rod Consumption (lb./100 ft)
1/16	F, H, V	None	1	3/32	1/16-3/32	3/8	16	70-100	8-10	0.5
	O	None	1	3/32	1/16-3/32	3/8	20	65-90	8-10	0.5
3/32	F	None	1	3/32-1/8	1/8-5/32	3/8	18	110-145	8-10	0.75
	H, V	None	1	3/32	3/32-1/8	3/8	18	90-125	8-10	0.75
	O	None	1	3/32	3/32-1/8	3/8	20	110-135	8-10	0.75
1/8	F	None	1	1/8	1/8-5/32	7/16	20	135-175	10-12	1
	H, V	None	1	1/8	3/32-1/8	3/8	20	115-145	8-10	1
	O	None	1	1/8	3/32-1/8	7/16	25	125-155	8-10	1
3/16	F	None	1	5/32	5/32-3/16	1/2	25	190-245	8-10	2.5
	H, V	None	1	5/32	5/32-3/16	1/2	25	175-210	8-10	2.5
	O	None	1	5/32	5/32-3/16	1/2	30	185-225	8-10	2.5
1/4	F	None	1	3/16	3/16-1/4	1/2	30	240-295	8-10	4.5
	H, V	None	1	3/16	3/16	1/2	30	220-265	8-10	4.5
	O	None	1	3/16	3/16	1/2	35	230-275	8-10	4.5
3/8	F		2	3/16	1/4	5/8	35	325-375	8-10	9.5
	V	Optional up to 250°F	2	3/16	3/16-1/4	5/8	35	280-315	8-10	9.5
	H	Max.	3	3/16	3/16-1/4	5/8	35	270-300	8-10	9.5
	O		3	3/16	3/16-1/4	5/8	40	290-335	8-10	9.5

1 F=Flat; V=Vertical; H=Horizontal; O=Overhead.

2 Preheating at excessive temperatures or for extended periods of time will reduce weld strength. This is particularly true for base metals in heat-treated tempers.

3 Number of weld passes and electrode consumption given for weld on one side only.

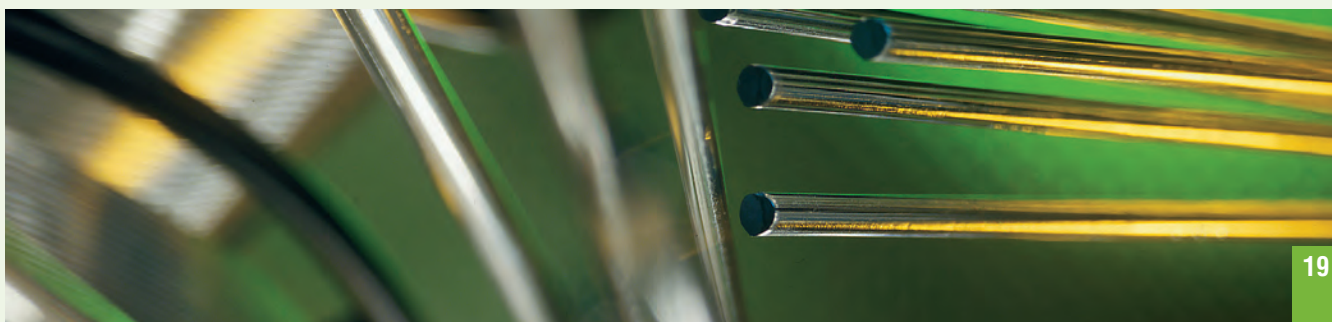

## Preferred Mode Of Metal Transfer To Be Used When MIG Welding Aluminum

### What is Metal Transfer?

**Metal Transfer** - The manner in which molten metal travels from the end of a consumable electrode across the welding arc to the workpiece. In MIG welding, the type of metal transfer employed is usually determined by the thickness of the material being welded and the size of the welding electrode being used and is directly influenced by current setting and shielding gas type employed during welding. The three principle modes of metal transfer are:

- 1. Short Circuit Transfer – Metal transfer in which molten metal from a consumable electrode is deposited during repeated short circuits.** This metal transfer which is sometimes known as short arc or dip transfer has been perfected for and is most widely used in the welding of thin gauge steels. Short circuit transfer produces a very low heat input and for this reason has the potential for producing incomplete fusion if used for aluminum. Short circuit transfer is not recommended for MIG welding of aluminum and has in the past been identified as such in technical publications and welding specifications.
- 2. Globular Transfer – The transfer of molten metal in large drops from a consumable electrode across the arc.** This transfer mode is not considered suitable for welding aluminum and is most predominantly used when welding carbon steel with CO<sub>2</sub> shielding gas.
- 3. Spray Transfer – Metal transfer in which molten metal from a consumable electrode is propelled accurately across the arc in small droplets.** When using argon, or an argon rich shielding gas with the MIG process the spray transfer mode can be achieved once the current increases above the globular-to-spray transition current. When we increase current to beyond the globular-to-spray transition current the metal transfer moves into spray transfer (The table below shows globular-to-spray transition currents for a selection of aluminum electrode diameters for welding aluminum). The spray transfer is a result of a pinch effect on the molten tip of the consumable welding wire. The pinch effect physically limits the size of the molten ball that can be formed on the end of the welding wire, and therefore only small droplets of metal are transferred rapidly through the welding arc from the wire to the workpiece. This transfer mode is characterized by its high heat input, very stable arc, smooth weld bead and very little if any spatter. Because spray transfer has a very high heat input which can overcome aluminum's high thermal conductivity, the spray transfer mode is recognized as the preferred mode of metal transfer for welding aluminum with the MIG process.

**Spray Transfer Transition Currents**

Wire Diameter inches (mm)	Shielding Gas	Spray Arc Transition Current
0.030 (0.8)	100% Argon	90 Amps ± 5 Amps
0.035 (0.9)	100% Argon	110 Amps ± 5 Amps
0.047 (1.2)	100% Argon	135 Amps ± 5 Amps
0.062 (1.6)	100% Argon	180 Amps ± 5 Amps

This table shows MIG globular-to-spray transition currents for a selection of aluminum electrode diameters for welding aluminum with pure argon shielding gas.



## Pulsed Spray Transfer MIG Welding Of Aluminum

Modern Pulsed MIG inverters have replaced conventional spray transfer MIG welders for many thin gauge aluminum applications, and they may also be a viable alternative in some conventional AC TIG applications. The pulsed MIG process makes this possible by providing more precise control of heat input, faster travel speeds, reduced potential for burn-through on thin gauge aluminum, and better control of the weld bead profile. *Some of the new pulsed MIG programs have been designed to produce welds with cosmetic profiles that are almost identical to the characteristic TIG weld profiles (see figure below).*

When considering a move to inverter pulsed MIG welding technology, evaluate these factors:

- 1 The ability to control heat input.** The pulses of peak current (which occur above the transition point) provide the good fusion associated with spray transfer, while the lower background current cools the weld puddle and allows it to freeze slightly to help prevent burn-through.
- 2 The ability to control bead profile.** Using a function called arc control, operators can adjust the width of the arc cone which lets them tailor the bead profile to the application. A wider bead can help tie-in both sides of a joint and a narrow bead helps provide good fusion at the root of a joint. A bead of the right size helps to eliminate excess heat input, over-welding, and post-weld grinding.
- 3 Superior arc starts.** A good pulsed MIG program for aluminum provides more energy at the start of the weld (which helps ensure good fusion) and then reduces energy to normal parameters for optimal welding characteristics.
- 4 Superior arc stops.** Today's pulsed MIG equipment provides the technology to ramp down to a cooler welding parameter to fill in the crater at the end of a weld. This helps to eliminate termination cracking which can be a serious issue when welding aluminum.
- 5 The ability to use a larger diameter wire to weld thin gauge material.** This can increase the deposition rate and aid feeding by using a stiffer wire, and can also save money on filler wire. The difference in cost between a 0.030" wire and a 0.047" wire, for instance, can be considerable.



Some of the new pulsed MIG programs have been designed to produce welds with cosmetic profiles that are almost identical to the characteristic TIG weld profiles.

**Note:** The top weld was produced with the Miller AlumaFeed™ System using a Profile Pulse™ program

## Obtaining A Stable Arc And Eliminating Erratic Feeding And Burnbacks

Most importantly, purchase Hobart products with controlled diameter, stiffness, cast, pitch, surface finish and low surface sliding friction. Secondly, always use a welding system that is designed specifically for welding aluminum like the Miller aluminum welding packages shown on pages 39 and 40 of this brochure. Welding systems like the Miller AlumaFeed have been specially developed and tested to provide high performance and to help eliminate the typical problems experienced when welding aluminum.

### Check List:

- Check and tighten electrical connections and grounding.
- Ensure that the base metal is not contaminated with water stains, moisture, heavy oxide, or hydrocarbon containing materials.
- Check that feed rolls, guides and contact tips meet Hobart's specified profile and surface polish recommendations. They must be free of burrs and machining marks. Use a push-pull wire feeder or spool gun for optimum feedability. See page 40 in this booklet.
- Match the contact tip size to the wire size being used (wire diameter + 10%).  
Caution: steel welding wires are produced to different sizes than aluminum. Using a contact tip designed for steel will cause excessive burn backs with aluminum wire because of inadequate diametrical clearance.
- Contact tips must be recessed in the gas cup 1/8 to 1/4 inch for proper gas cooling of the tip and spatter control. Do not use jogged contact tips.
- Prevent overheating of the gun and contact tip by operating at a reduced duty cycle or switching to a water cooled gun.

## Purchasing Contact Tips And Maintenance Suggestions:

Purchase contact tips with bore sizes that are 10% larger than the electrode diameter.

Warning: A 3/64" (0.047") diameter aluminum electrode is a different size than 0.045" diameter steel electrode and takes a different size tip. For instance a 0.052" diameter tip is the correct size for 3/64" aluminum wire.

Contact tips for steel are stamped 0.045" and are not to be used with an aluminum electrode. Purchase contact tips that have polished bores free from burrs on the inlet and exit ends.

- If the contact tip that you are using does have inlet and exit burrs, remove the burrs and polish the bore with a circular wire file.
- Recess the tip 1/8" to 1/4" into the gas cup to promote tip cooling and to reduce spatter and oxide accumulation that acts like burrs at the end of the contact tip.
- Replace all metallic wire guides with non-metallic material. Ask equipment manufacturers for their non-metallic guide kits.



## Drive Roll Design And Wire Feedability

All too often the incorrect choice of drive rolls is a major cause of aluminum welding wire feedability problems. The greatest majority of these problems are caused by aluminum wire shavings that originate from poor fitting and incorrectly designed drive rolls.

Listed below are suggestions on how to select the correct type and design of drive rolls:

### Improperly Designed Drive Rolls Can Produce Problems

- A rough surface finish produces fines and aluminum buildup in the groove. Sharp edges and misalignment of the rolls can shave the wire.
- Shavings and fines can cause plugged liners and tips, aluminum buildup on the feed rolls distorts the wire and can cause poor feedability and erratic arc stability.

### Recommended Design

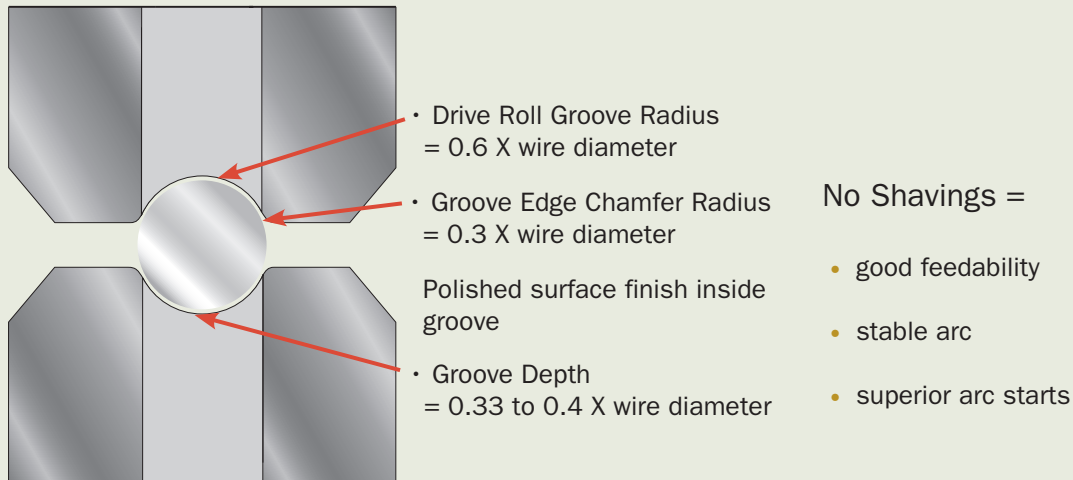

#### Note:

Polish all groove surfaces, ensure both rolls are aligned, and always use the lowest drive roll pressure capable of feeding the wire in order to prevent deformation of the wire during feeding.

## Weld Joint Porosity

**Porosity** — Cavity-type discontinuity formed by gas entrapment during solidification.

Producing a weld with low porosity is the responsibility of both the electrode manufacturer and the welder. The electrode manufacturer must supply an electrode that is contamination free and has been tested to show that it is indeed capable of meeting the low porosity standards of AWS A5.10. The welder must incorporate the practices and procedures of codes like AWS D1.2 to ensure that porosity is not introduced into the weld pool. Before welding, process engineers must determine which porosity standard of the applicable code the welded structure is required to meet.

All weld porosity results from the absorption of hydrogen during melting and the expulsion of hydrogen during solidification of the weld pool. The solubility of hydrogen in aluminum increases dramatically after the material reaches its liquid stage. When the aluminum is taken to temperatures above its melting point it becomes very susceptible to hydrogen absorption (see hydrogen solubility chart below). The hydrogen can then form bubbles in the molten aluminum as it solidifies and these bubbles are then trapped in the metal causing porosity.

The cause of porosity in aluminum is hydrogen. The sources of hydrogen that create porosity are:

- Hydrocarbons – In the form of paint, oil, grease, other lubricants and contaminants
- Hydrated aluminum oxide – Aluminum oxide can absorb moisture and become hydrated - the hydrated oxide will release hydrogen when subjected to heat during welding
- Moisture (H<sub>2</sub>O) – Moisture within the atmosphere can be a serious cause of porosity under certain circumstances - see the calculation of dew point table on page 25. Moisture from other external sources such as compressed air, contaminated shielding gas or from pre-cleaning operations must also be considered.

Note: Hydrogen gas from these sources can become trapped within the weld deposit and create porosity

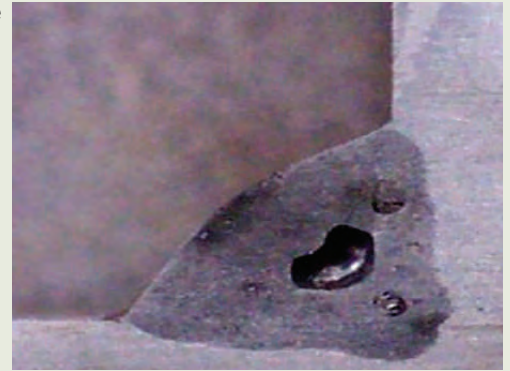

Macroetch of fillet weld showing large irregular shaped porosity.

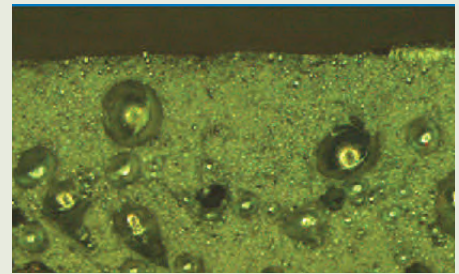

Scattered porosity found in the internal structure of an aluminum weld after nick-break testing.

### Hydrogen Solubility in Aluminum

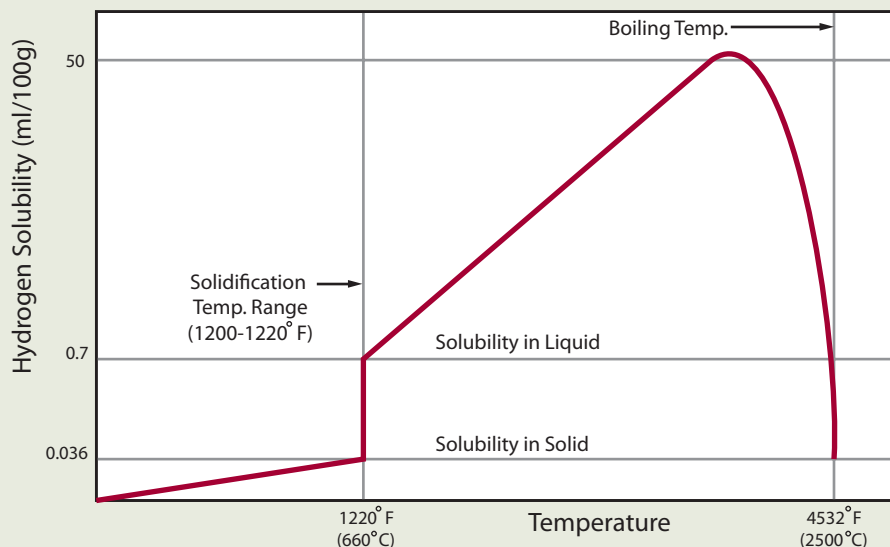

## Tips For Reducing Weld Joint Porosity

### Some Methods that can be used to Help Meet Low Porosity Standards.

When experiencing porosity problems the first course of action is to identify the source of hydrogen that is responsible for producing the porosity.

- Purchase Hobart MAXAL Mig and MAXAL Tig brand electrodes and rods that have been diamond shaved to eliminate harmful oxides, manufactured with procedures to provide low residual hydrogen containing compounds and then have been weld tested to the stringent AWS A5.10 standard.
- Purchase low dew point shielding gases (Argon or Argon/Helium mixtures). Helium mixtures reduce porosity.
- Clean base metals by solvent cleaning or etching and then stainless steel wire brushing prior to assembling the weld joint. A number of commercial cleaners are available but not all are suitable for this cleaning operation. The solvent must completely evaporate before welding.
- Use shielding gas flow rates and purge cycles recommended for the welding procedure and position being used.
- Monitor torch angle to ensure air is not being aspirated into the protective inert gas shield. The standard forehand angle is 10° to 15° from perpendicular.
- Increase gas cup size and gas flow rate, if required.
- Ensure that the base metal and electrode are not wet with condensation. Bring the metal in from a cooler plant location (outside for example) and allow it to sit in the welding area for 24 hours before welding. Put spacers between the base metal members (plates for example) to allow air to circulate. Allow the welding material to reach room temperature prior to welding. Do not attempt to dry metal with an oxyfuel torch since it will only add moisture to the metal surface and further hydrate the surface oxide already present.
- Store unpackaged electrode and rods in a heated cabinet or room to prevent them from cycling through dew points, creating hydrated oxide on their surface. See page 25 (calculation of dew point chart).
- Do not weld in drafty conditions.
- Avoid excessive spatter buildup inside gas nozzle.
- Use the correct contact tip to work distance.
- Avoid exhaust contamination from compressed air tools.
- Do not use anti-spatter compounds.
- Check for water leaks in water-cooled welding systems.
- Check for cooling system shut off capability between duty cycles.
- Check for inadequately pure shielding gas (as supplied). Argon should be 99.997% pure (-76°F or lower) dew point. Helium should be 99.995% pure (-71°F or lower) dew point.
- Check for imperfections within the gas delivery line such as leaks.
- Prevent hydrated aluminum oxide.
- Avoid cutting fluids and saw blade lubricants.
- Avoid grinding disc debris.

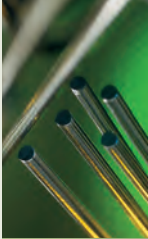

## Calculation of Dew Point

Air Temp F	Relative Humidity %									
	100	90	*80	70	60	50	40	30	20	10
110	110°F	106°F	102°F	98°F	93°F	87°F	80°F	72°F	60°F	41°F
100	100°F	97°F	93°F	89°F	84°F	78°F	71°F	63°F	52°F	32°F
90	90°F	87°F	83°F	79°F	74°F	68°F	62°F	54°F	43°F	32°F
80	80°F	77°F	73°F	69°F	65°F	59°F	53°F	45°F	35°F	
*70	70°F	67°F	63°F	59°F	55°F	50°F	44°F	37°F		
60	60°F	57°F	53°F	50°F	45°F	41°F	35°F			
50	50°F	46°F	44°F	40°F	36°F					
40	40°F	37°F	34°F							
32	32°F									
	<b>Calculated Dew Point</b>									

**Warning:** If the filler metal or base metal is below the calculated Dew Point condensation will form on the material causing weld discontinuities.

### How to read the chart:

Read the Air Temp in the left hand column and humidity along the top of the chart.

\*For example: If the air temperature in the welding area is 70F and the humidity is **80%**, the intersection of the two shows the dew point in the area to be 63F. If the metal brought into the welding area is below 63F, moisture will condense on the metal causing welding quality problems.

### One of the most common mistakes that aluminum welding fabricators make is best described with the following example.

Take a large aluminum fabricator located in a warm climate near the ocean.

At night, the building where welding of components is conducted cools down considerably. During the night there is a light rain and the next morning the relative humidity of the air outside is high (80%). In the morning the welders come to work and the doors are closed. The temperature in the manufacturing area has slowly cooled down to 60 degrees F. All of the aluminum in the factory including the welding wire is also 60 degrees F.

Then, someone decides to get some warmer fresh air in the factory and throws the large overhead doors open. In comes the very warm air from outside and now you have 80 degree F air with 80% relative humidity hitting metal that is 20 degrees colder. If you look at the chart above you can see that for an air temperature of 80 degrees F and a relative humidity of 80% , the metal can only be a maximum of 7 degrees F colder than the ambient air or you will cross the dew point and visible moisture will condense out of the air onto the metal. Once this has happened you have to stop welding until the metal is dried. Remember that moisture hydrates the aluminum oxide present on all aluminum and may cause irreparable damage.

## How To Avoid Cracking In Aluminum Alloys

The majority of aluminum base metals can be successfully arc welded without cracking related problems, however, using the most appropriate filler alloy and conducting the welding operation with an appropriately developed and tested welding procedure is significant to success. (For information on exceptions to this statement see page 9 “Non-Weldable Aluminum Base Metals”)

### The Primary Cracking Mechanism in Aluminum Welds (Hot Cracking)

Hot cracking is the cause of most cracking in aluminum weldments. Hot cracking is a high-temperature cracking mechanism and is mainly a function of how metal alloy systems solidify. There are three areas that can significantly influence the probability for hot cracking in an aluminum welded structure:

1. Susceptible base material chemistry that effects the probability of cracking.
2. Selection and use of the most appropriate filler metal to help prevent the formation of a crack sensitive chemistry.
3. Choosing the most appropriate joint design that will provide the required dilution of filler metal and base metal in order to avoid a crack sensitive chemistry in the weld.

### Hot Crack Sensitivity Curves

Aluminum crack sensitivity curve diagrams are a very helpful tool for understanding why aluminum welds crack and how the choice of filler alloy and joint design can influence crack sensitivity. The diagram shows the effects of four different alloy additions - Silicon (Si), Copper (Cu), Magnesium (Mg), and Magnesium Silicide (Mg<sub>2</sub>Si) – on the crack sensitivity of aluminum. The crack sensitivity curves reveal that with the addition of small amounts of alloying elements, the crack sensitivity becomes more severe, reaches a maximum, and then falls off to relatively low levels. After studying the crack sensitivity curves, it is easy to recognize that most of the aluminum base alloys considered unweldable autogenously (without filler alloy addition) have chemistries at or near the peaks of crack sensitivity. Additionally, the chart shows that alloys that display low cracking characteristics have chemistries well away from the crack sensitivity peaks.

### Controlling Hot Crack Sensitivity in the Weld

Based on this information, it is clear that crack sensitivity of an aluminum base alloy is primarily dependent on its chemistry. Utilizing these same principals, it can be concluded that the crack sensitivity of an aluminum weld, which is generally comprised of both base alloy and filler alloy, is also dependent on its chemistry. With the knowledge of the importance of chemistry on crack sensitivity of an aluminum weld, two fundamental principles apply that can reduce the incidence for hot cracking. First, when welding base alloys that have low crack sensitivity, always use a filler alloy of similar chemistry. Second, when welding base alloys that have high crack sensitivity use a filler alloy with a different chemistry than that of the base alloy to create a weld metal chemistry that has low crack sensitivity. When considering the welding of the more commonly used 5xxx series (Al-Mg) and the 6xxx series (Al-Mg-Si) aluminum base alloys, these principles are clearly illustrated.

### The 5xxx Series Alloys (Al-Mg)

The majority of the 5xxx base metals, which contain around 5% Mg, (5086, 5083) show low crack sensitivity. These base metals are easy to weld with a filler metal that has Mg content similar to the base metal. This will usually provide a weld with excellent crack resistance. These alloys should not be welded with a 4xxx series filler alloy as excessive amounts of magnesium silicide can form in the weld and produce a joint with undesirable properties. There are base alloys within the 5xxx group, such as 5052, that have a Mg content that falls very close to the crack sensitivity peak. In the case of these alloys, definitely avoid welding autogenously. The Mg base alloys like 5052 with nominal Mg contents up to 2.5%, can be welded with both the 4xxx filler alloys, such as 4043 or 4047 and the 5xxx filler alloys such as 5356.

Solidification Cracking Curves

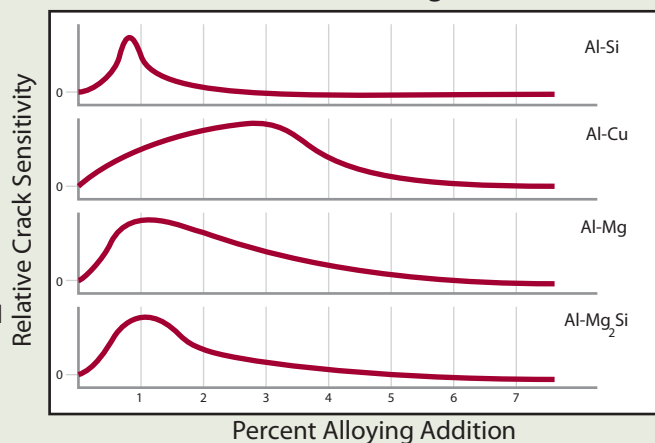

## The 6xxx Series Alloys (Al-Mg-Si)

The aluminum/magnesium/silicon base alloys (6xxx series) are of a chemistry that makes them crack sensitive because the majority of these alloys contain approximately 1.0% Magnesium Silicide ( $Mg_2Si$ ), which falls close to the peak of the solidification crack sensitivity curve. The  $Mg_2Si$  content of these materials is the primary reason there are no 6xxx series filler alloys. Using a 6xxx series filler alloy or autogenously welding would invariably produce cracking problems in the weld. During arc welding, the cracking tendency of these alloys is adjusted to acceptable levels by the dilution of the base material with excess magnesium (by use of the 5xxx series Al-Mg filler alloys) or excess silicon (by use of the 4xxx series Al-Si filler alloys). Particular care is necessary when TIG welding on thin sections of this type of material. It is often possible to produce a weld, particularly on outside corner joints, without adding filler material by melting both edges of the base material together. These types of techniques should be avoided as the absence of filler metal will produce welds that are extremely susceptible to cracking.

## The Effect of Welding the 6xxx Series Base Metals without Filler Metal Addition (Autogenously)

Below we see two welds made on a 6061-T6 plate one weld with a 4043 filler alloy and one weld without any filler alloy added.

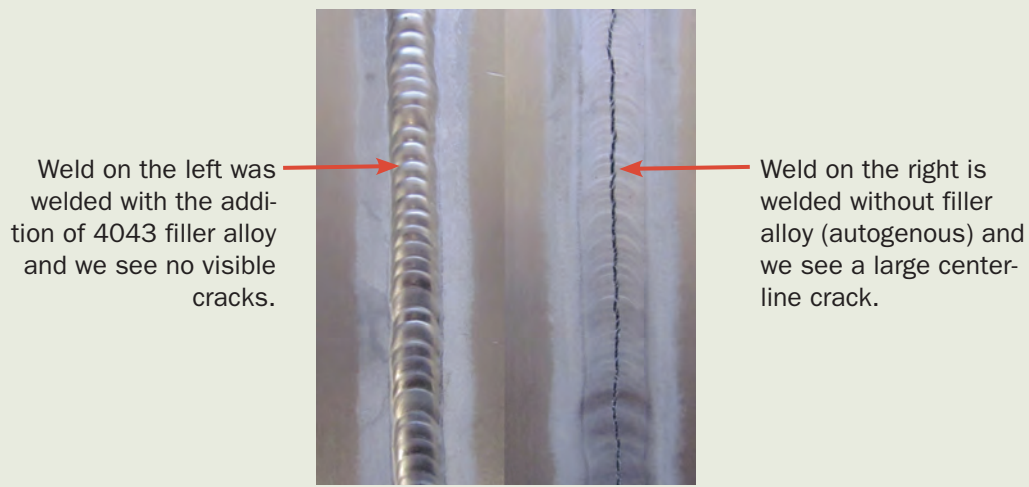

### Visual Inspection of two welds made with the TIG process on base alloy 6061-T6

Note: the extent of cracking within a weld without filler metal will be dependant on the degree of shrinkage stress that is developed during the welding operation. The addition of filler metal lowers the crack sensitivity of the weld and dramatically reduces the probability of hot cracking.

## The Effect of Weld Joint Design on Hot Crack Sensitivity:

When arc welding these base metals the addition of filler metal is required in order to produce a chemistry in the weld that will create consistent crack free welds.

- a. Weld joint designed with no bevel resulting in significant base metal melting



20% Filler Metal – 5356 (5% Mg)  
80% Base Metal – 6061 (1% Mg) } 1.8% Mg (crack-sensitive)  
No Bevel

- b. Weld joint designed with a bevel resulting in reduced base metal melting



60% Filler Metal – 5356 (5% Mg)  
40% Base Metal – 6061 (1% Mg) } 3.4% Mg (Not crack-sensitive)  
Beveled

**Note:** If we check the hot crack sensitivity curves, on page 26, we will see that 1.8% Mg has high crack sensitivity and 3.4% Mg has comparatively low crack sensitivity. (On this premise it is safe to say that the weld with the square edge preparation is very likely to crack.)

## The Secondary Cracking Mechanism in Aluminum Welds (Stress Cracking)

- **Problem:** Excessive shrinkage rates during weld solidification and further cooling.  
**Solution:** The filler metal choice has an effect on shrinkage stress. Silicon filler metals (4xxx) have lower solidification and reduced cooling shrinkage rates than Mg filler alloys. Therefore, 4xxx filler alloys have lower shrinkage stresses and produce reduced stress cracking.
- **Problem:** Excessive base metal melting and increased shrinkage stresses resulting from too slow a travel speed.  
**Solution:** Increase travel speed to narrow the heat affected zone and reduce melting.
- **Problem:** A fillet weld that is too small or concave may not withstand shrinkage stresses, and crack.  
**Solution:** Increase fillet size and/or adjust weld profile.
- **Problem:** A weldment that is highly restrained during the welding process may develop excessive residual stresses which may result in welding cracking.  
**Solution:** Remove excessive restraint and/or apply a compressive force during welding.
- **Problem:** Termination cracking at the end of the weld bead (crater cracks).  
**Solution:** Termination cracks can be reduced by increasing travel speed at the termination of the weld, by doubling back for a short distance at the end of the weld or by re-arc-ing the wire several times into the puddle to add additional weld metal to the solidifying weld pool. Welding equipment with a Crater Fill feature is the best method of preventing this problem. For this reason Miller aluminum welding packages are provided with crater fill as a standard feature (see page 39 and 40).

## Weld Discoloration, Spatter And Black Smut

4xxx series filler metals produce less weld discoloration, spatter and smut than 5xxx series filler metals. The Magnesium in 5xxx alloys vaporizes in the arc and condenses as a black powder next to the weld bead. The Mg in 5xxx alloys has a lower vapor pressure than either silicon or aluminum when melted in the arc. This lower vapor pressure of Mg increases vaporization and causes some disintegration of the transferring droplet as separation from the tip of the electrode occurs. Small spatter and vaporized Mg are thrown outside of the arc plasma column. Increased black smut and spatter are encountered next to the weld bead with 5xxx filler metal alloys.

Hobart manufactures all of its products to minimize weld discoloration, spatter, and smut from contamination.

Introduction of oxygen into the shielding gas envelope via air, moisture, and contaminants will increase the burning (oxidation) of the filler metal producing discoloration, spatter, and smut.

### To Minimize Weld Discoloration, Spatter and Black Smut:

- Use a 4xxx filler alloy vs 5xxx.
- Air contains both oxygen and moisture which causes weld discoloration and smut buildup.

To minimize air in the shielding gas do the following:

- Decrease gun angle (the typical forehand angle is 10°-15° from perpendicular).
- Increase gas cup size.
- Hold gas cup closer to base metal.
- Shield arc from drafts.
- Clean spatter buildup from gas cup.
- Check gun and hoses for water leaks.
- Shut the welding gun's cooling water off when the gun is not in use.



- Keep electrode covered while on the welding machine or in storage to minimize oxidation, moisture condensation, and other contamination.
- Degrease base metal with the correct solvents.
- Solvent clean and stainless steel brush or etch and stainless steel brush the base metal weld joint prior to fit-up to remove water stains and heavy oxides. Stainless steel brushing should only be done after solvent cleaning. Stainless steel brushing prior to solvent cleaning traps hydrocarbons in the base metal surface.

## Weld Bead Root Penetration And Fusion

Penetration and fusion are controlled by the welder, the weld joint design, the weld procedure, the welding equipment, and the shielding gas characteristics.

### To Increase Root Penetration and Fusion:

- Increase welding amperage and reduce arc travel speed (while staying in front of the puddle).
- Decrease arc length and/or increase amperage to increase penetration.
- For better fusion, solvent clean and then wire brush base metal prior to fit-up to remove hydrocarbons and oxides. Fusion will not occur across an oxide barrier.
- Remove all edges that have been cut with a band saw.
- For heat treatable aluminum alloys, remove all edges that have been cut by melting.
- Use stringer beads, do not weave.
- Redesign the weld joint to improve access to the root, incorporate a 60° bevel to allow better penetration and wider fusion in the weld root.

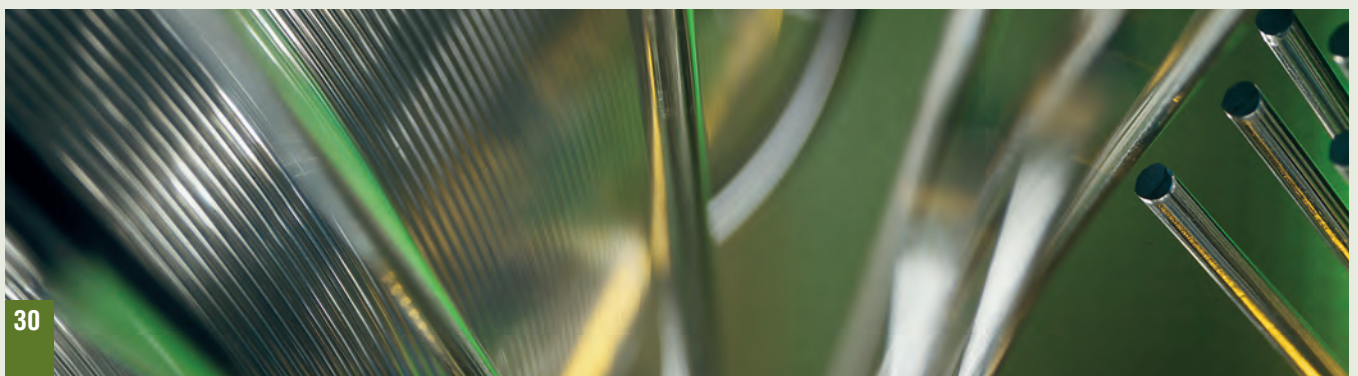



## Weld Bead Contour and Penetration

The Aluminum Association deals briefly with this subject in their publication entitled, *Welding Aluminum: Theory and Practice*. They state that the welder learns to set the correct arc length mostly by sight and sound, which is true. But, we have expanded on this subject here in order to provide a better understanding of the science involved and to give more guidance on what the effects are of changing the voltage and amperage in the welding process.

The voltage, amperage, and travel speed selected to make a MIG weld determines the shape, size, and penetration of the weld bead. The shape, size, and penetration of the weld bead required for a specific welded component varies based on the weld joint design, section sizes of the components being welded and on the mechanical strength requirements of the finished weldment. Other considerations such as visual requirements are also to be considered. Describing the numerous physical effects of varying arc voltage and amperage during welding is best done using a chart. We have done this by assuming that the travel speed is held constant. The results shown in the chart are governed by a simple electrical formula which reads as follows:

$$\text{Volts} \times \text{Amps} = \text{Watts (heat)}$$







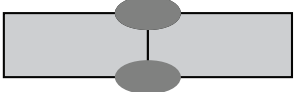
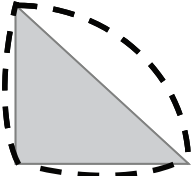
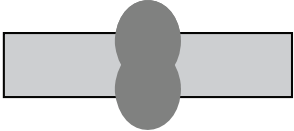

This formula says that the total heat in the weld is the product of the volts and amps selected. Voltage controls the length of the arc. As the voltage is increased, the arc length increases. As the arc length is increased, the weld bead penetration is decreased, and the weld bead profile becomes lower and wider. With increasing arc length, droplet transfer becomes less stable at the electrode tip, expelling spatter particles from the plasma column. Amperage also has an effect on weld penetration. As the amperage is increased, the weld bead penetration is increased. In the following chart, we have listed the various welding characteristics in the left hand column and in the next two columns we show the effects of varying voltage and varying amperage. A practical application of this information is encountered when welding with the Mg based 5xxx series filler metals versus the Si based 4xxx series filler metals. Because the Mg carries less heat to the base plate than the Si in these alloys, the 5xxx filler metals are welded with a shorter arc length. For 5xxx series electrodes use a welding current in the high side of the range with an arc voltage in the lower side of the range giving a crackling sound when welding. For the 4xxx series electrodes use lower currents and higher arc voltages giving a humming sound when welding. When welding with the 1xxx and 2xxx series electrodes use the same general practice as for the 4xxx series electrodes.

Welding Characteristic	Lower Voltage	Higher Voltage
Arc length	Shorter	Longer
Weld bead height	Higher	Lower
Weld bead width	Narrower	Wider
Weld bead penetration	Deeper	Shallower
Weld bead surface porosity	More	Less
Arc sound	Crackling	Humming
Spatter	Less	More

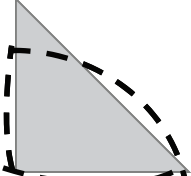
Welding Characteristic	Lower Heat Input	Higher Heat Input
Arc voltage/amperage	Lower	Higher
Weld bead surface	Rippled	Smoother
Weld bead root porosity	More	Less
Weld bead penetration	Shallower	Deeper
Smut	Less	More

# Solving Weld Profile Problems

## Weldment Profile Problems per AWS D1.2

Fillet	Butt	Effect on Weldment	Remedies and Corrections
		Reduced weld strength and increased sensitivity to crack propagation	<ul style="list-style-type: none"> <li>• Increase heat and/or decrease arc length, decreasing travel speed, forehand torch angle</li> </ul>
		Reduced fatigue strength	<ul style="list-style-type: none"> <li>• Increase arc length and/or torch angle</li> </ul>
		Reduced mechanical properties	<ul style="list-style-type: none"> <li>• Decrease travel speed and/or arc length</li> </ul>
		Reduced mechanical properties	<ul style="list-style-type: none"> <li>• Change torch angle and/or torch position</li> <li>• Decrease arc length</li> <li>• Match base metals with equal thermal conductivities</li> <li>• Concentrate the arc on the base metal with the higher thermal conductivity</li> </ul>
		Reduced mechanical properties & fatigue strength	<ul style="list-style-type: none"> <li>• Change torch position to compensate for dissimilar section thicknesses or dissimilar thermal conductivity sections</li> </ul>
		Reduced fatigue strength	<ul style="list-style-type: none"> <li>• Increase welding heat</li> <li>• Use correct torch angle</li> <li>• Wire brush to remove heavy oxide layers</li> </ul>

### Simple procedure for inspecting weld profiles by macro etching



- Band saw and belt sand a cross sectional sample of the weld joint.
- Heat up sample in hot water. Spray the cross section with Easy Off oven cleaner.
- Let stand for 5 minutes and rinse.

Note: *Easy Off* oven cleaner contains caustic soda which etches the cross section of the sample showing the weld bead profile and penetration.

# The Guided Bend Test

Passing the guided bend test during welding procedure and welder performance qualification can depend on how the test is performed just as much as the quality of the weld. If a guided bend test is not conducted correctly for aluminum, the test can fail no matter how good the weld is. Problems associated with not passing the guided bend test are most often the result of not following the test method instructions of the welding code correctly. The areas that are most often responsible for this problem are as follows:

- 1 Using the plunger type rather than the wraparound guided bend jig** - The AWS D1.2 code is very clear in stating that the wraparound bend jig is the preferred method of bend testing aluminum weldments and even provides an explanation in the commentary as to why. The plunger-type test jig may prove suitable for some of the low strength base materials. However, it is MAXAL's opinion that the wraparound bend jig should be used for all aluminum alloys.
- 2 Incorrect Preparation of the Bend Test Samples** - This may be as simple as not applying the required radius to the edges of the test specimen or producing specimens of an incorrect size. However, it is most often associated with not applying the alloy specific special bending conditions contained within the code. This paragraph is entitled – Special Bending Conditions – M23, M24, M27 Base Metal, and F23 Filler Metal. If the instructions contained within the special bending requirements paragraph of the AWS D1.2 Code are not followed you may experience major problems during bend testing. Because of very different as-welded mechanical properties within the different groups of materials (aluminum alloys), different alloy groups must be tested in very different ways. Some of the variations that are alloy-group specific are: reducing the specimen thickness to 1/8 inch prior to bending, subjecting the specimen to heat-treatment after welding in order to anneal the specimen prior to testing, the use of alloy-specific and temper condition bend diameters, and even a restriction associated with the maximum amount of time permitted to elapse prior to testing is applied to one particular alloy group. Unfortunately, not following these special requirements correctly and consequently not applying the correct requirements to the specific alloy being tested appears to be one of the primary causes for failing guided bend tests conducted on samples that appear to be of sound integrity.

## Guided Bend Testing

### Corner Radius & Sample Thickness

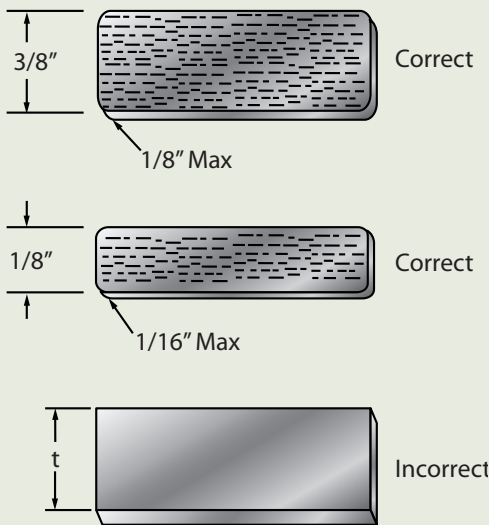

### Wraparound Guided Bend Jig

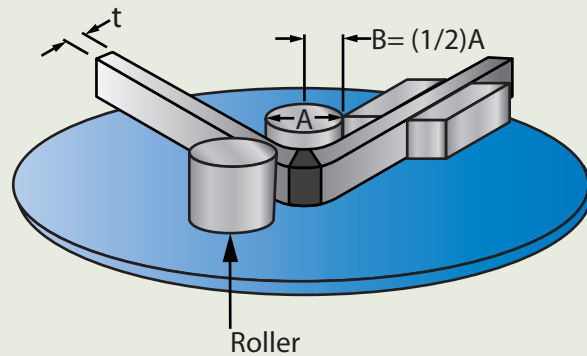

THICKNESS	A	B	MATERIALS
3/8"	1 - 1/2"	3/4"	M21 & M22
t	4t	2t	
1/8"	2 - 1/16"	1 - 1/32"	M23 & F23
t (<1/8)	16-1/2t	8-1/4t	
3/8"	2 - 1/2"	1 - 1/4"	M25
t	6-2/3t	3-1/3t	
3/8"	3"	1 - 1/2"	M24 & M27
t	8t	4t	

## The Transverse Tension Test

The transverse tension test is a standard method of testing prescribed by welding codes and standards for welding procedure qualification (WPS) of groove welds. The most common problems associated with failing the transverse tension test are associated with not understanding how aluminum base alloys can lose strength through exposure to high temperature during arc welding. Aluminum base alloys are divided into two types, the “heat treatable” and the “non-heat treatable” alloys. When we arc weld the non-heat treatable materials we change the heat affected zone (HAZ) section of the base material from a typically strain hardened condition to an annealed condition. This loss of strength in the non-heat treatable materials is not usually a problem when qualifying welding procedures as this reduced value is the value used as the minimum strength requirement by the welding code.

The problem of reducing the HAZ strength to below what is acceptable by the welding code is common when qualifying a WPS that is using a heat treatable base metal. A base material such as 6061-T6 that is in a solution heat-treated and artificially aged condition can have its strength seriously reduced during arc welding. If we overheat the HAZ of this type of material during welding, we can quite easily reduce the strength in this area to a value below that of the minimum tensile strength requirement specified by the code. Some of the areas that need to be considered in order to reduce the potential for overheating and the consequent test failure are as follows:

- 1 The code will typically provide minimum dimensions for groove weld test plate size. You must comply with this requirement; in fact, if practical, use a larger test sample than specified. This will provide for superior heat sink capacity and lower the possibility of excessive overheating and prolonged time at temperature within the heat-affected zone.
- 2 Comply with the preheating and interpass temperature requirements of the code, which for this type of material specifies 250 deg F as the maximum preheat and interpass temperature. Try to conduct the certification testing without preheating, or at lower preheating temperatures (150 deg F), and allow the base material to cool to well below the maximum interpass temperature before welding is resumed.
- 3 A major contributor to the overall heat input of a weld is the travel speed during the welding process. For this reason, it is preferable to select a welding sequence and technique which makes use of faster stringer beads, do not use slower weaving techniques.

Minimum Tensile Strength for Welding Procedure Qualification			
Material	Alloy and Temper	Product Thickness	Minimum Tensile Strength (Ksi)
M25	5083-0	Sheet 0.051-1.500	40
	5083-H112	Plate 0.051-1.500	40
	5083-H116	Plate 1.50-3.000	39
M23	6061 - T4, T451	All Thru 3.000	24
	6061 - T51, T6		
	6061 - T62, T651		

**Note:** These figures are extracted from the AWS D1.2 Structural Welding Code for Aluminum Welding – Tensile Strength of Aluminum Alloys Table.

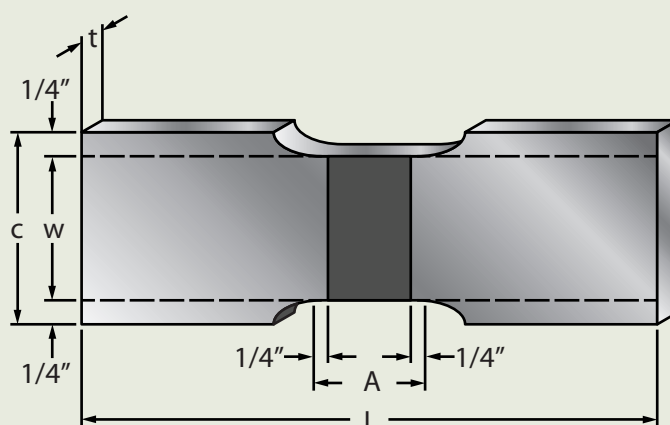

Test Plate
A - Reduced Length
L - Length
W - Reduced Width
C - Grip Width
t - Thickness

# Specifications, Codes & Certifications

## Chemistry Certifications: AWS Classifications

### Alloy Classification Chemistry Requirements to AWS Specifications

AWS A5.10 establishes specific chemistry requirements for MIG and TIG consumables. These have been evaluated to establish safety criteria for each alloy. The designation of ER for MIG products and R for TIG products establishes the specification chemistry limits that have been approved for each welding consumable. Some aluminum alloys are approved for TIG welding processes and not for MIG processes. The MIG process produces more metallic vapors than the TIG process and therefore has more restrictions on chemistries. AWS A5.10 identifies these analysis limits as ALLOY CLASSIFICATIONS.

### Typical Test Report (AWS A5.01)

A non-standard term which does not have a consistent definition. See Certificate of Compliance or Certificate of Conformance.

### Certificate of Compliance (COC)

A statement that the product meets the requirement of the AWS specification/classification. The Maxal certificates of compliance include a chemical analysis of a similar lot processed in the year. Maxal certificates of compliance can be found at [maxal.com](http://maxal.com).

### Certified Material Test Report (CMTR)

A test report where there is specific reference to the tests being conducted on the actual material supplied. The CMTR may contain results of some or all of the tests required for classification, or other tests as agreed upon by the purchaser and supplier. See Annex D of AWS A5.01 for more details. Maxal Certified Material Test Reports specific to every lot shipped can be found at [maxal.com](http://maxal.com).



## American Welding Society Control Documents

### Weld Wire Purchasing • Weld Wire Manufacturing • Welding Aluminum Structures

The American Welding Society has three specifications that work hand-in-hand to insure the correct materials are purchased, manufactured, tested, qualified, and welded into structures that meet the requirements of the consumer.

- AWS A5.01 The specification for purchasing aluminum welding electrode and rods to meet the manufacturer's requirements for the end product being welded.
- AWS A5.10 The specification standard that controls the manufacturing, testing, chemical composition, packaging, and identification of all aluminum filler metals.
- AWS D1.2 The code that controls welder and welding procedure qualification and quality requirements of the weldment.

#### AWS A5.01 Procurement Guidelines for Consumables

The requirements for each welded structure must be fully determined by the purchaser. The AWS A5.01 specification allows manufacturers to purchase aluminum electrode and rods to four lot classifications (S1 through S4). Each classification ensures that the producer of the consumable meets specific requirements. Classification S1 is the lot requirement as specified in the electrode manufacturer's quality assurance manual. S2 through S4 specifies items such as production sequences and heat or controlled chemistry reporting of alloy composition analysis, etc. The specification specifies various levels of testing for the consumable. The levels of testing vary from Schedule F through K. Schedule F is the consumable manufacturer's base standard. Levels G through K give other specific requirements. One of the most frequently used schedules for critical, dynamically loaded weldments is schedule J. Schedule J requires that each lot of material shipped per the requirements of this specification be tested to the usability test found in AWS A5.10 (weld test and x-ray for MIG electrode or bead on plate test for TIG rods).

#### AWS A5.10 Specification for Bare Aluminum and Aluminum Alloy Welding Electrodes and Rods

This specification provides requirements governing the manufacture, alloy classification, identification, testing procedures and requirements, and packaging of aluminum electrodes and rods. The customer specifies the product requirements in AWS A5.01. The consumable manufacturer produces the product to the order requirements ensuring conformance to AWS A5.10 and identifies the product classification on the product label. Key elements of the A5.10 specification are the product quality test procedures and quality requirements. For example, the test procedures for 1/16 inch diameter and smaller electrodes state that they are to be welded in the overhead weld position to maximize the capture of porosity generated by the welding electrode. This ensures a very thorough testing of the electrode's quality when radiographically tested.

#### AWS D1.2 Structural Welding Code - Aluminum

All manufacturers of aluminum structures should consider using this code for the control of their welding operations. D1.2 provides the manufacturer with three fundamental requirements for establishing a quality control system. The three fundamentals are qualified welding procedures, requirements for qualifying welders, and acceptance criteria for the production and inspection of weld quality. Quality and inspection standards are provided for statically and cyclically loaded structures. It is critical that the manufacturer understand the customer's purchase order requirements for the welded structures he is producing and establish the required quality control system for his welding operation to meet those requirements.

#### Quality Assurance Through AWS Specifications Conformance

The AWS specifications establish a complete system from order requirements to final fabricated product to ensure that the critical characteristics of the end product are met. The AWS specifications play a fundamental role in this supply chain process to assure consistent quality performance on everyone's part. Purchase of high quality Hobart aluminum welding consumables plays a major part in meeting the requirements of any aluminum welding fabricators quality assurance system.

## Welding Design Information and Technical Assistance

### American Welding Society [www.aws.org](http://www.aws.org)

550 LeJeune Road, Miami, FL 33126

- AWS A5.01/A5.01M, Procurement Guidelines for Consumables
- AWS A5.10/A5.10M, Specification for Bare Aluminum and Aluminum Alloy Welding Electrodes and Rods
- AWS D1.2/D1.2M, Structural Welding Code – Aluminum
- AWS D10.7/D10.7M, Guide for Gas Shielded Arc Welding of Aluminum and Aluminum Alloy Pipe
- AWS, Welding Aluminum – Questions and Answers
- AWS, Pocket Handbook: GMAW of Aluminum
- AWS, Welding Handbook

### The Aluminum Association [www.aluminum.org](http://www.aluminum.org)

1525 Wilson Boulevard, Suite 600, Arlington, VA 22209

- Welding Aluminum Theory and Practice
- International Alloy Designations and Chemical Composition Limits for Wrought Aluminum and Wrought Aluminum Alloys
- Aluminum Brazing Handbook
- Aluminum Design Manual, Specification and Guidelines for Aluminum Structures
- Aluminum Soldering Handbook
- Aluminum Standards and Data
- Designation System for Aluminum Finishes
- Designation and Chemical Composition Limits for Aluminum Alloys in the Form of Castings and Ingots
- Forming and Machining Aluminum
- Guidelines for Use of Aluminum with Food and Chemicals

### American National Standards Institute (ANSI) [www.ansi.org](http://www.ansi.org)

25 West 3rd Street, 4th Floor, New York, NY 10036-7046

- ANSI H35.1/H35.1(M), Alloy and Temper Designations for Aluminum

### American Society for Testing and Materials (ASTM) [www.astm.org](http://www.astm.org)

100 Bar Harbor Drive, West Conshohocken, PA 19428-2959

- ASTM B 918-01, Standard Practice for Heat Treatment of Wrought Aluminum Alloys
- ASTM E 142, Standard Method for Controlling Quality of Radiographic Testing

### ASM International [www.asminternational.org](http://www.asminternational.org)

9639 Kisman Road, Materials Park, OH 44073-0002

- ASM Aluminum: Properties and Physical Metallurgy
- ASM Specialty Handbook – Aluminum and Aluminum Alloys

## Conversion Tables

Approximate conversion values for English to metric and metric to English

To Convert From English to Metric	Multiply By Divide By	To Convert From Metric to English
inches	2.540	centimeters
inches	25.40	millimeters
feet	0.3048	meters
yards	0.9144	meters
ounces (adp)	28.35	grams
troy ounces	31.10	grams
pounds (adp)	0.4536	kilograms
short tons	0.9071	metric tons
fluid ounces	29.57	milliliters
quarts	0.9464	liters
gallons	3.785	liters
pounds/in <sup>2</sup>	0.006895	Newtons/mm <sup>2</sup> (MPa)
1 metric ton = 2,205 lbs.		

Fraction	Decimal	Millimeters	Aluminum Feet Per lb.	Aluminum Feet Per kg.	Approximate Wire Gauge
—	.023	0.6	2083	4592 (1400 m)	23
—	.030	0.8	1215	2678 (816 m)	20 1/2
—	.035	0.9	900	1984 (605 m)	19
—	.040	1.0	704	1552 (473 m)	18
3/64	.047	1.2	520	1146 (349 m)	17
—	.059	1.5	308	679 (207 m)	15
1/16	.062	1.6	290	639 (195 m)	14
—	.079	2.0	172	379 (116 m)	12
3/32	.093	2.4	130	287 (87 m)	11
1/8	.125	3.2	70	154 (47 m)	8
5/32	.156	4.0	45	99 (30 m)	6 1/2
3/16	.187	4.7	31	68 (21 m)	4 1/2
1/4	.250	6.3	20	44 (13 m)	2



### Traceability of Electrode and Rod

- Traceability to lot heat chemistries of the metal
- Traceability to conformance of AWS A5.10 and A5.01 requirements
- Traceability to conformance of MAXAL's quality control system requirements
- TIG rods embossed with alloy designation

### Certifications and Society Approvals

- ISO 9001 certified production facility
- MSDS information sheet contained in each package
- Each spool identified with appropriate multilingual warning labels
- All products fabricated to the AWS A5.10 standard and A5.01 class S1, schedule F and also schedules G-K and class S2, S3, and S4 are all available on request
- ABS (American Bureau of Ships) society approval
- CWB (Canadian Welding Bureau) society certification to the AWS A5.10 standard
- CE, CPD, DB, vdTUV

### Quality of Electrode and Rod

- Maximized electrode feedability through precise diameter size control, wire columnar strength control and low surface sliding friction
- Maximized welding consistency through specific controlled chemistries and wire diameter control to 1/10th of the AWS standard
- Minimized welding porosity through process control and x-ray testing
- Minimized welding smut, spatter and weld discoloration through electrode surface oxide and cleanliness control
- Optimized packaging - plastic wrapped electrodes and rods in unique high strength reusable cartons

### Customer Support

- Same day shipment from inventory
- Competitive product pricing
- Large finished goods inventory
- Technical brochure
- Training seminars (next page)
- Technically trained sales network
- Factory based welding engineers and metallurgists available for assistance and problem solving

For more information, go to the Hobart web site at [www.hobartbrothers.com](http://www.hobartbrothers.com)

### The Hobart Statement of Limited Liability

*Taking into consideration the effects of design criterion, the suitability of design for the end use, the variability of the physical and mechanical properties of aluminum alloys and the many variables present in the welding fabrication process itself, MAXAL provides the information in this booklet as a general guide only. MAXAL recommends that all welding specifications, practices and procedures be thoroughly tested for their intended use before being put into service. The information in this booklet is presented as a general guideline only. Hobart makes no warranties expressed or implied with regard to this information.*

# Advanced Aluminum Welding Technology Seminar

This seminar is offered by Hobart Aluminum Industry Experts

## Course Overview:

To provide professionals, active in the design and fabrication of aluminum structures, educational support in the areas of welding technology associated with designing and welding of aluminum structures. This will include a detailed evaluation of the many aluminum alloys, their characteristics and applications, metallurgical considerations, welding procedure development, welding processes, weld design, weld discontinuities, trouble shooting welding problems and quality control.

## Course Outline – Theory

Take away every usable **FACT** about welding aluminum

### Introduction:

- Industry trends
- Characteristics of aluminum
- Applications
- MAXAL's guide for aluminum Welding

### Codes and Standards:

- Review of AA and AWS publications
- Alloy & temper designation system

### Metallurgy:

- History of aluminum production
- Alloy system characteristics of element additions
- Effect of alloying elements on structure
- Weld bead, fusion zone and heat affected zone

### Weld Preparation:

- Metal storage considerations
- Dew point calculations

- Cutting, thermal and mechanical
- Cleaning techniques

### Welding Processes and Procedures:

#### GMAW (MIG) Welding

- Feedability
- Polarity/arc cleaning
- Metal transfer modes
- Power sources

#### GTAW (TIG) Welding

- Polarity
- Wave formation, square wave
- Tungsten electrode selection

### Design and Performance:

- Corrosion types and performance
- Elevated temperature performance
- Strength performance, tensile and shear
- Weld joint design
- Toughness/elasticity/ductility
- Fatigue performance

- Post anodize color matching

### Filler Metal Selection:

- Weld metal properties
- How to use the MAXAL filler metal selection chart
- Case studies

### Weld Discontinuities - Cause and Correction:

- Weld cracking
- Porosity
- Inadequate fusion and penetration

### AWS/D1.2

### Structural Welding Code - Aluminum:

- Structural design
- Procedure qualification
- Performance qualification
- Fabrication and inspection

## Course Outline – Practical

Experience the practical **FEEL** of a successful aluminum weld

### Welding Procedures:

- Safety procedures
- WPS preparation
- Sample preparation
- Pre-weld inspection
- Welding machine set up

### Fillet Welds & Groove Welds:

- Select base and filler metal
- Prepare and clean base metal
- Review and select equipment settings

### Welding, Testing and Inspection:

- Create weldments
- Record settings, practice and produce samples
- Visually inspect weldments
- Perform a fillet weld fracture test and inspection
- Perform a fillet weld macroetch specimen and inspection
- Perform a groove weld guided bend test (Root and face bends)
- Evaluation of radiographic (X-ray) inspection



For more information and registration information contact Peggy Moehn. Email [peggy.moehn@MillerWelds.com](mailto:peggy.moehn@MillerWelds.com) or Tel. 920-735-4101

# Miller Solutions Made for Aluminum



Miller offers a complete line of welding equipment that is easy to use and provides advanced features for welding aluminum such as hot start and crater fill parameters. This equipment with its superior puddle control and consistent arc quality is designed to produce x-ray quality welds for your aluminum welding needs.

Miller built the first TIG welders in 1946, invented AC Squarewave technology in 1976 and has continued to lead the industry ever since. Miller TIG inverters provide superior arc performance that allows TIG perfection time and time again. Aluminum MIG applications provide increased productivity. Miller has designed MIG equipment that feeds aluminum consistently, offers excellent arc performance and is easy to use. Through superior controls and equipment design, Pulsed MIG has also become very easy to use and to train operators to make quality welds. In addition, the appearance of Pulsed MIG welds in some applications can rival that of a TIG weld.

**MRO and Sign Applications:** Our welding machines are rugged and reliable with simplified control panels, easy maintenance features and unrivaled quality, making aluminum welding profitable.

**Pipe, Tube, Plate and HVAC Fabrication Applications:** Our advanced features give you the precision you need at a price you can afford.

**Ships/Boats, Emergency Vehicles, Aerospace and Trailer Applications:** Whether you're doing a high volume of aluminum welding or performing high quality welds, Miller aluminum machines offer the most controlled arcs in the industry—helping you to reach your production goals with ease, and the portability you demand.

**Automotive and Automation Applications:** Productivity is key when implementing a newly automated system or expanding an existing operation. Miller high volume production aluminum welders will meet your needs today.

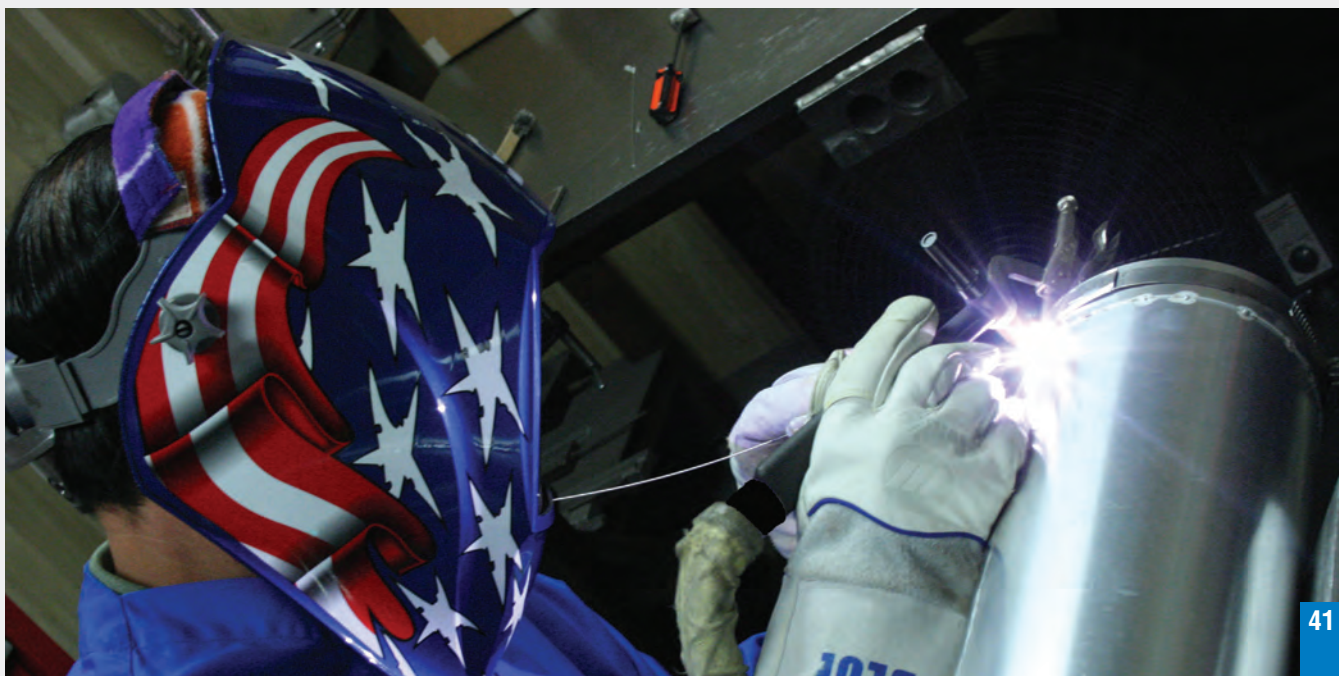

## Industrial Aluminum MIG Solutions



### Millermatic® 350P

Cost effective, light industrial all-in-one MIG/Pulsed MIG solution with easy-to-use interface for aluminum and steel wire welding on material up to 1/2 inch thick. Features built-in running gear for mobility.



### AlumaFeed™ Synergic Aluminum System

Dedicated industrial-fabrication aluminum welding solution with advanced welding features that can handle larger weldments. Its lightweight push-pull feeder can easily be carried up to 135 feet from the power source for added portability.



### Invision™ MPA Plus System

Versatile industrial advanced system for large, high-duty cycle aluminum and steel weldments. Features push and/or push-pull benchtop feeder for easy switchover between solid, aluminum and tubular wires.

## Industrial Aluminum TIG Solutions



### Dynasty® 200, 350, 700

Dynasty welders feature advanced inverter technology for the most flexible AC/DC TIG/STICK solutions in the welding industry. Compact, mobile designs offer superior arc performance and puddle control that set new standards for productivity and weld quality, while providing electrical savings and lowering the cost of operations.

*For the highest-quality aluminum welds—there's only one choice: Miller*

**MillerWelds.com**



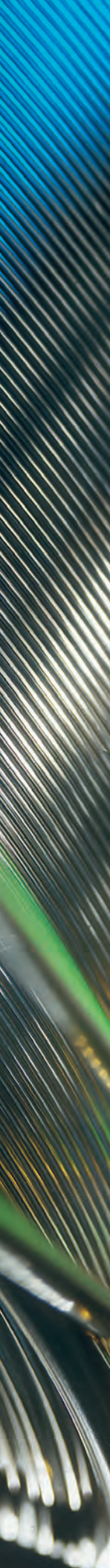
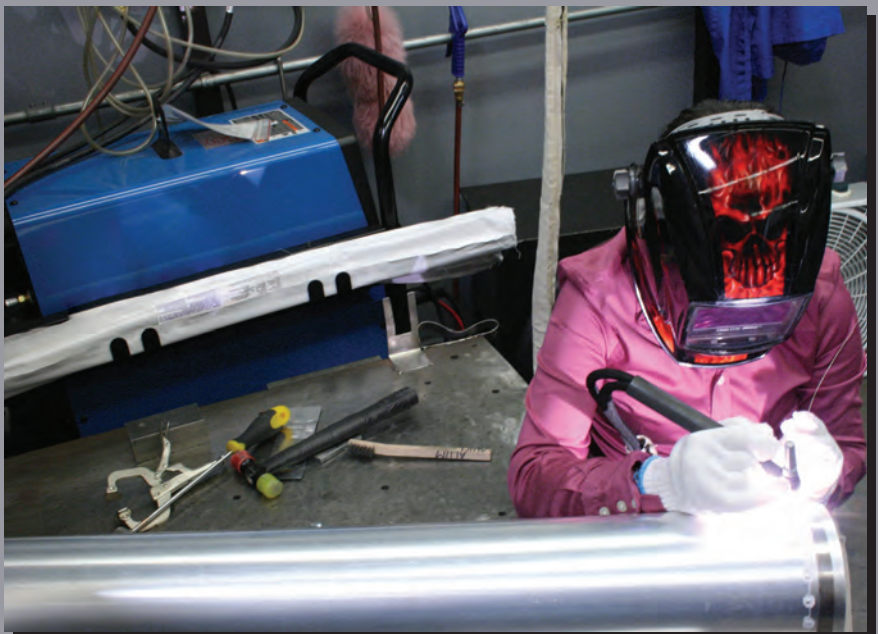

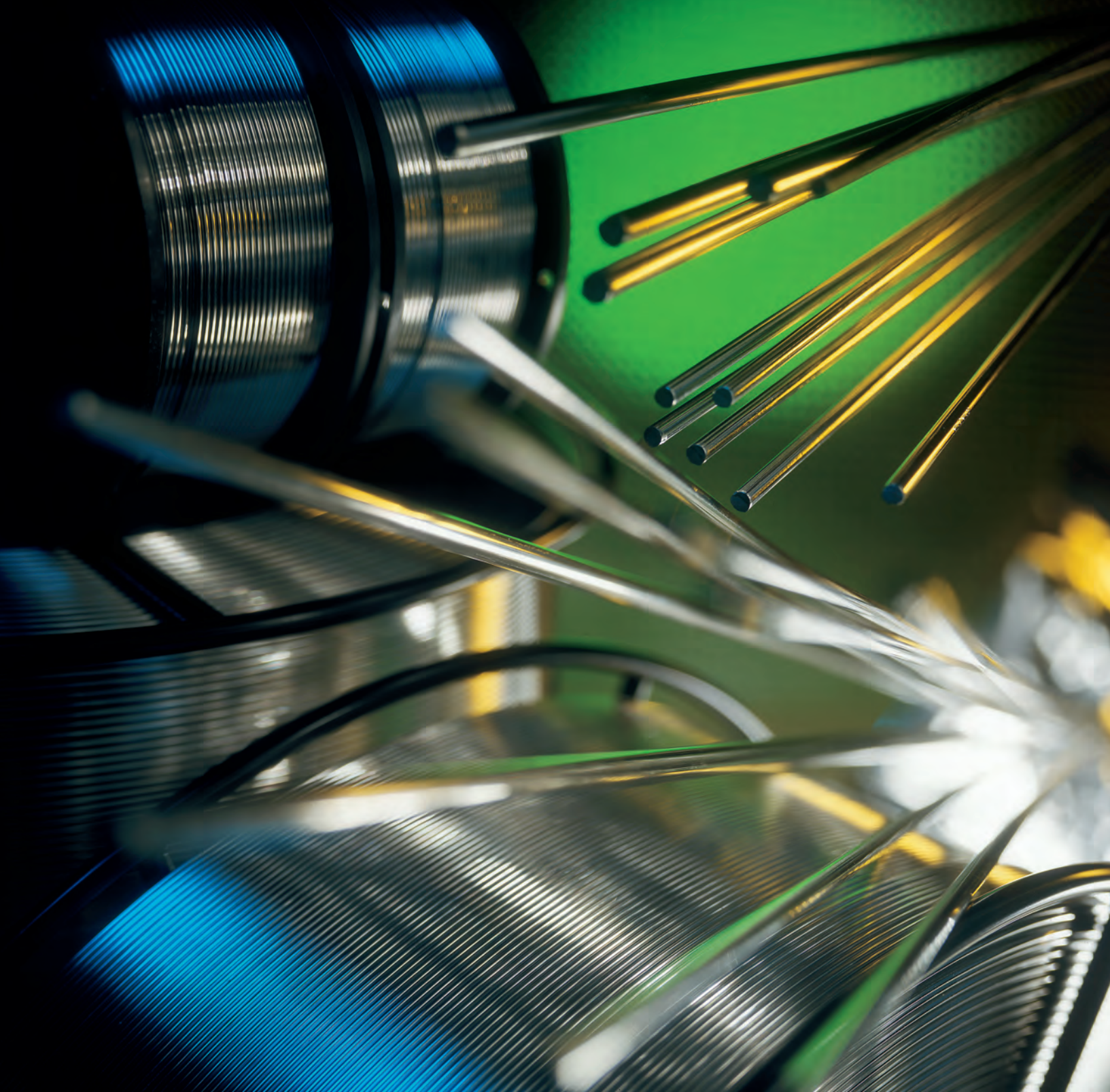

**The Welder's Choice for  
Quality Aluminum Weld Wire**

**HobartBrothers.com**

©2019 Hobart Brothers LLC.  
Hobart and the Hobart logo are trademarks of Illinois Tool Works, Inc.

**To place an order:  
Hobart Brothers LLC  
Phone: 800-424-1543  
Fax: 800-541-6607**

**For technical assistance:  
877-629-2564**

HOB-ALU 102513

\$15 USD