

Series 30™

Medium-Duty Single-Stage Pressure Regulators

Quick Specs

Applications

Farm and ranch
Construction and fabrication
Heavy equipment
Shipbuilding
Scrap and salvage

Oxy-Fuel Processes

Cutting, heating, welding and brazing

Gas Service

Oxygen, acetylene, LP gas, argon/nitrogen, carbon dioxide and hydrogen/methane

Max. Delivery Pressure

Cylinder: Up to 150 psig (10 bar)
Purge: 450 psig (31 bar)

Max. Inlet Pressure

Cylinder: 400 or 3,000 psig (28 or 207 bar)
Purge: 3,000 psig (207 bar)

Outlet Connection

Cylinder: 9/16"-18 LH or RH "B" or 5/8"-18 RH internal
Purge: 7/16"-20 RH external flare

CGA Inlet Connection

Cylinder: 200, 300, 320, 350, 510, 520, 540 or 580
Purge: 580

Regulator Body Inlet

1/4" NPT

Temperature Range

-20° – +140°F (-29° – +60°C)

Net Weight

1.5 lb. (0.68 kg)

Accurate pressure control. Reliable for daily use.



30-15-510



Sure Seat™

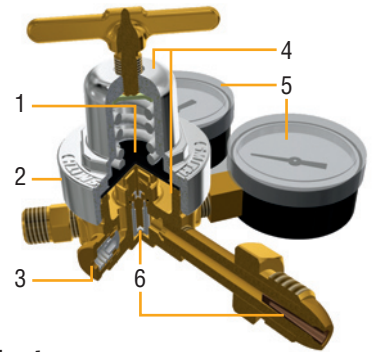

Features

- 1. Neoprene composite diaphragm** resists corrosion for extended service life.
- 2. Color-coded labels** supply performance capabilities, easy gas service identification and technical information.
- 3. External relief valve** protects regulator from damage due to inadvertent high-pressure surge. Relief valve will release excessive pressure and automatically reset.
- 4. Brass body and nickel-plated bonnet** protect against corrosion.
- 5. Easy-to-read 2-inch gauges with shatter-resistant polycarbonate lens covers.**
- 6. Dual filters including Sure Seat** protect high-pressure seat from debris for reliable operation and long service life.



Warrantied for three years, parts and labor.



Underwriters Laboratories (UL) Listed



Miller Electric Mfg. LLC

An ITW Welding Company
1635 West Spencer Street
P.O. Box 1079
Appleton, WI 54912-1079 USA

Equipment Sales US and Canada

Phone: 866-931-9730
FAX: 800-637-2315
International Phone: 920-735-4554
International FAX: 920-735-4125

MillerWelds.com



Purge Regulator



30-450-580

This regulator is used with nitrogen in HVAC systems to test and locate leaks or purge refrigerant lines and equipment for installation and repair. Compact for limited space.

Performance Data

These flow charts are used to determine whether or not your regulator has the flow capability necessary for your application.

How to use a flow chart:

There are multiple ways to use a flow chart. Each method relies on a pair of known values for inlet pressure, outlet pressure, or flow rate to determine the third. For example, if the inlet and outlet pressures are known and you wish to know the flow rate, the following steps may be used:

1. Identify curve corresponding to the system's inlet pressure. Different colors or symbols may be used to differentiate one inlet pressure from another.
2. Find desired outlet pressure on vertical axis.
3. Move horizontally across the chart until the line corresponding to the desired outlet pressure intersects the curve corresponding to the inlet pressure.
4. Read the flow rate marked along the horizontal axis.

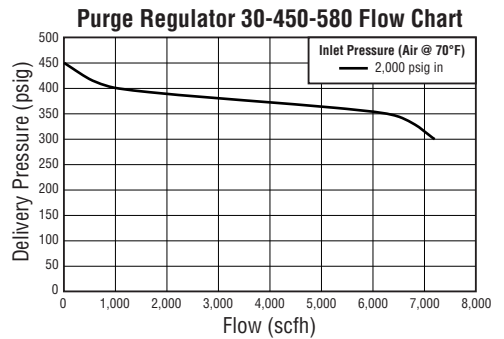
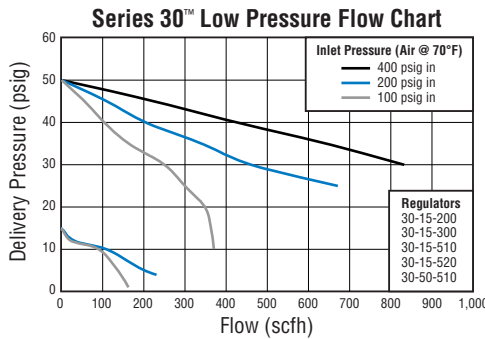
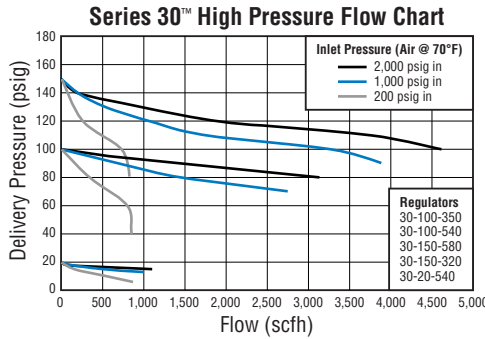

Ordering Information

Stock No.	Gas Service	Inlet Gauge	Outlet Gauge	Max. Delivery Pressure	Max. Inlet Pressure	Outlet Connection	Inlet Connection
Cylinder Regulators							
30-100-540	Oxygen	0–4,000 psig (0–280 bar)	0–150 psig (0–10 bar)	100 psig (7 bar)	3,000 psig (207 bar)	9/16"-18 RH "B"	CGA 540
30-20-540			0–30 psig (0–2 bar)	20 psig (1.4 bar)			
30-15-510	Acetylene	0–400 psig (0–28 bar)	0–30 psig (0–2 bar)	15 psig (1 bar)	400 psig (28 bar)	9/16"-18 LH "B"	CGA 510
30-15-300							CGA 300
30-15-520							CGA 520
30-15-200							CGA 200
30-50-510	LP gas *	0–400 psig (0–28 bar)	0–60 psig (0–4 bar)	50 psig (3 bar)	400 psig (28 bar)	9/16"-18 LH "B"	CGA 510
30-100-350	Hydrogen/methane	0–4,000 psig (0–280 bar)	0–150 psig (0–10 bar)	100 psig (7 bar)	3,000 psig (207 bar)	9/16"-18 LH "B"	CGA 350
30-150-580	Argon/nitrogen	0–4,000 psig (0–280 bar)	0–200 psig (0–14 bar)	150 psig (10 bar)	3,000 psig (207 bar)	5/8"-18 RH internal	CGA 580
30-150-320	CO ₂	0–4,000 psig (0–280 bar)	0–200 psig (0–14 bar)	150 psig (10 bar)	3,000 psig (207 bar)	5/8"-18 RH internal	CGA 320
Twin Packs — Consist of 30-100-540 oxygen regulator and either 30-15-510 (HTP2) or 30-15-300 (HTP5) acetylene regulator							
HTP2	Oxygen/acetylene	0–4,000 psig (0–280 bar)/ 0–400 psig (0–28 bar)	0–150 psig (0–10 bar)/ 0–30 psig (0–2 bar)	100 psig (7 bar)/ 15 psig (1 bar)	3,000 psig (207 bar)/ 400 psig (28 bar)	9/16"-18 RH "B"/ 9/16"-18 LH "B"	CGA 540/ CGA 510
HTP5							
Purge Regulator							
30-450-580	Nitrogen	0–4,000 psig (0–280 bar)	0–600 psig (0–40 bar)	450 psig (31 bar)	3,000 psig (207 bar)	7/16"-20 external flare fitting	CGA 580

*Propane, propylene or natural gas.

Distributed by:

