

Heating Tips

Quick Specs	Typical Applications	Oxy-Fuel Processes	Fuel Gases	Tip Types	Gas Mixing
	Shipbuilding Railroad Salvage Pipeline	Farm and ranch Metal fabrication Construction and demolition	Heating Brazing Soldering	Specialty Heavy-duty Medium-duty Standard-duty	In the tip

Quick concentrated heat for maximum performance.

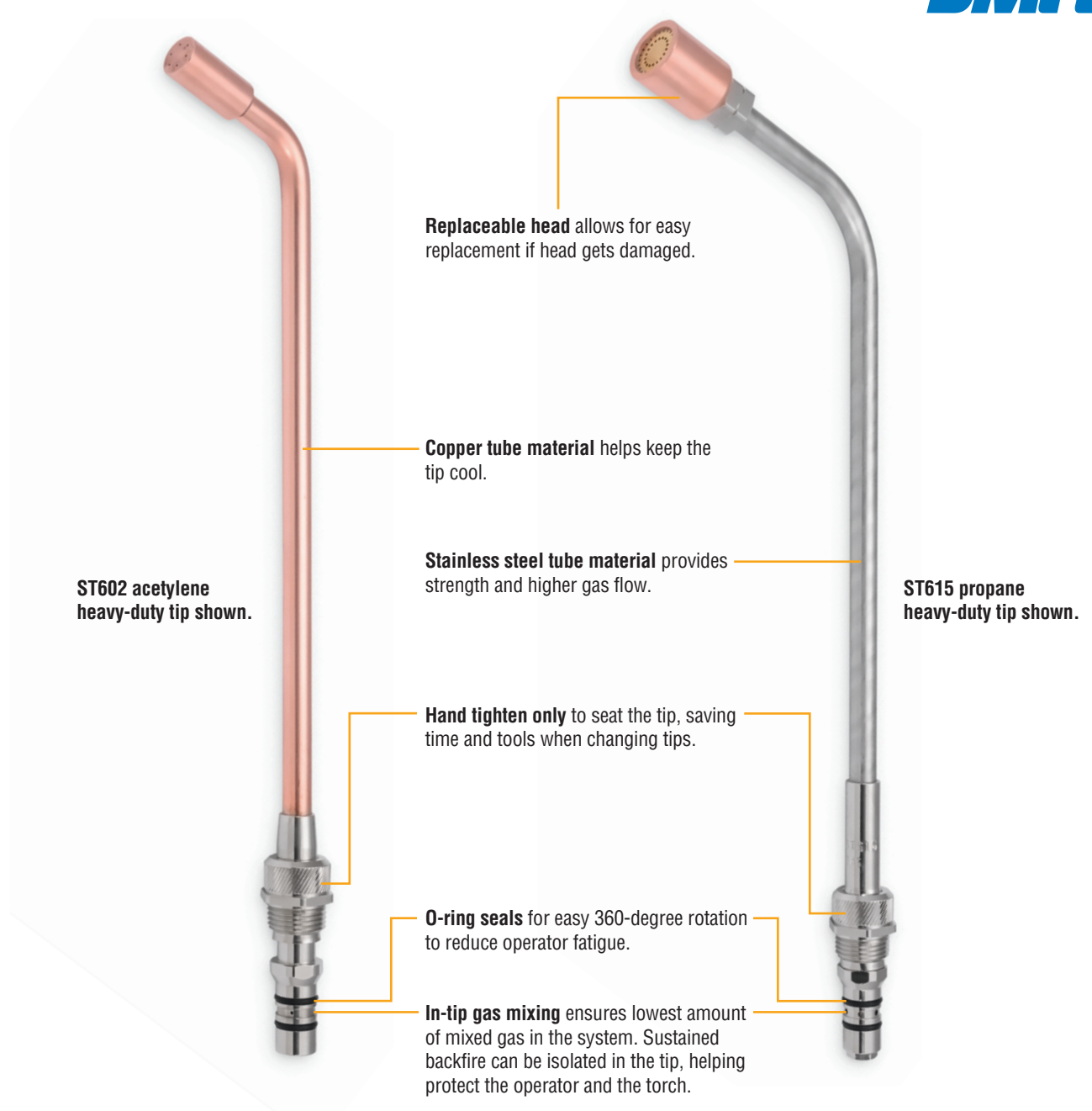

Miller Electric Mfg. LLC
 An ITW Welding Company
 1635 West Spencer Street
 P.O. Box 1079
 Appleton, WI 54912-1079 USA

Equipment Sales US and Canada
 Phone: 866-931-9730
 FAX: 800-637-2315
 International Phone: 920-735-4554
 International FAX: 920-735-4125

MillerWelds.com



ST600 Series Heavy-Duty Heating Tips (Acetylene)

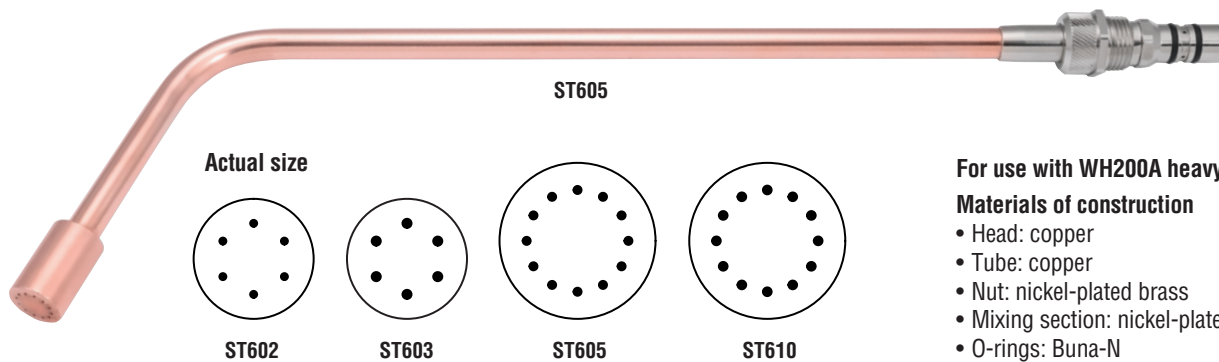

For use with WH200A heavy-duty torch handle.

Materials of construction

- Head: copper
- Tube: copper
- Nut: nickel-plated brass
- Mixing section: nickel-plated brass
- O-rings: Buna-N

Gas Service	Stock No.	Average Btu/Hour	Pressure (psig)		Gas Consumption (scfh)		Drill Size	Overall Length	350 Cubic Foot Fuel Cylinders Required
			Oxygen	Acetylene	Oxygen	Acetylene			
Acetylene	ST602	41,160	15	15	31	28	64	16 in. (406 mm)	1
	ST603	73,500	15	15	55	50	56	16 in. (406 mm)	1
	ST605	141,120	15	15	96	87	57	19 in. (483 mm)	2
	ST610	220,500	15	15	150	136	54	19 in. (483 mm)	3

ST600 Series Heavy-Duty Heating Tips (Propane/Natural Gas)

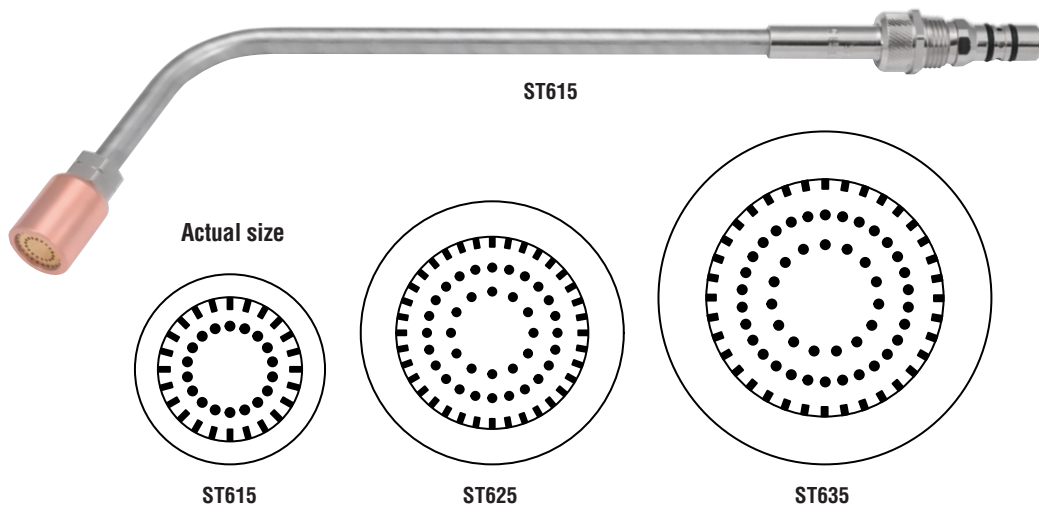

For use with WH200A heavy-duty torch handle.

Materials of construction

- Head shell: copper
- Head insert: brass
- Head nut: nickel-plated brass
- Tube: stainless steel
- Nut: nickel-plated brass
- Mixing section: nickel-plated brass
- O-rings: Buna-N

Gas Service	Stock No.	Average Btu/Hour	Pressure (psig)		Gas Consumption (scfh)		Overall Length	Head Number
			Oxygen	Fuel Gas	Oxygen	Fuel Gas		
Propane/ natural gas	ST615	244,000	23-65	10-28 (propane)	225-535	70-160 (propane)	15.5 in. (394 mm)	1495
		155,145	18-55	10-28 (natural gas)	175-450	92-267 (natural gas)		
	ST625	455,000	50-110	17-28 (propane)	480-1,000	140-280 (propane)	31.5 in. (800 mm)	1504
		313,950	43-80	18-28 (natural gas)	390-785	200-450 (natural gas)		
	ST635*	614,195	70-115	18-40 (propane)	670-1,580	185-480 (propane)	31.5 in. (800 mm)	1499

*ST635 requires 3/8 inch (10 mm) I.D. hose and 40-50-510 propane cylinder regulator.

ST800 Series Heavy-Duty Heating Tips (Propylene)

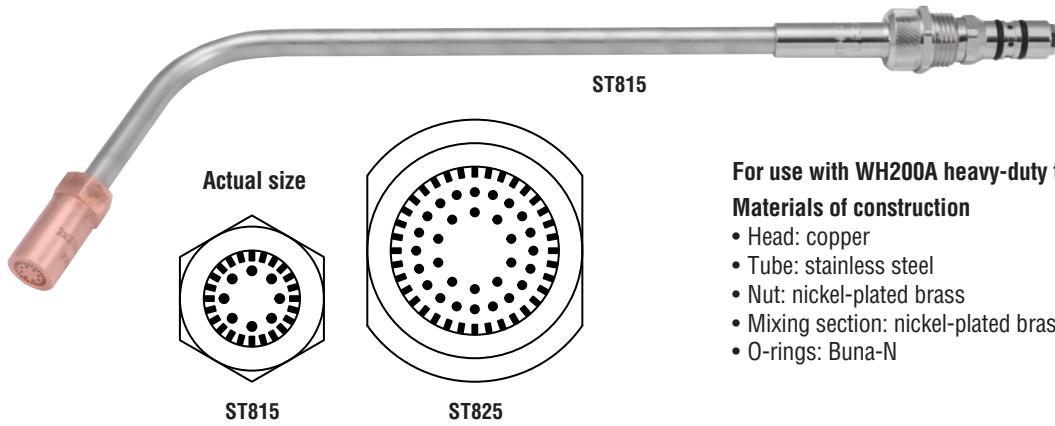

For use with WH200A heavy-duty torch handle.

Materials of construction

- Head: copper
- Tube: stainless steel
- Nut: nickel-plated brass
- Mixing section: nickel-plated brass
- O-rings: Buna-N

Gas Service	Stock No.	Average Btu/Hour	Pressure (psig)		Gas Consumption (scfh)		Overall Length	Torch Head Number
			Oxygen	Propylene	Oxygen	Propylene		
Propylene	ST815	273,000	37-77	13-37	390-655	120-235	16 in. (406 mm)	4642
	ST825	830,000	60-110	20-35	580-1,500	225-525	16 in. (406 mm)	4639

SC Series Heavy-Duty Special-Purpose Tips (Acetylene or Propane)

Actual size

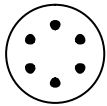

SC83

SC83 materials of construction

- Body: tellurium copper
- Seat: graphite
- Seat collar: brass

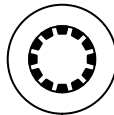

SC112

SC112 materials of construction

- Insert: brass
- Sleeve: brass
- Shell: nickel-plated tellurium copper
- Seat: graphite
- Seat collar: brass

For use with the following torches:

Cutting torches: SC220, SC225, SC229, SC229S, SC360, SC365, SC369, SC925, SC929, SC930, SC935, SC939, SC940, SC945, SC949, SC960, SC965, SC969

Machine torches: SC770, SC772A

Gas Service	Stock No.	Average Btu/Hour	Pressure (psig)		Gas Consumption (scfh)		Drill Size	Overall Length	Fuel Cylinders Required
			Oxygen	Fuel Gas	Oxygen	Fuel Gas			
Acetylene	SC83	76,440	15	10 (acetylene)	58	52 (acetylene)	56	3.5 in. (89 mm)	2 (350 cu. ft. cylinders)
Propane	SC112	312,250	60	25 (propane)	495	125 (propane)	Slots	3.5 in. (89 mm)	2 (100 lb. cylinders)

MT600 Series Medium-Duty Heating Tips (Acetylene)

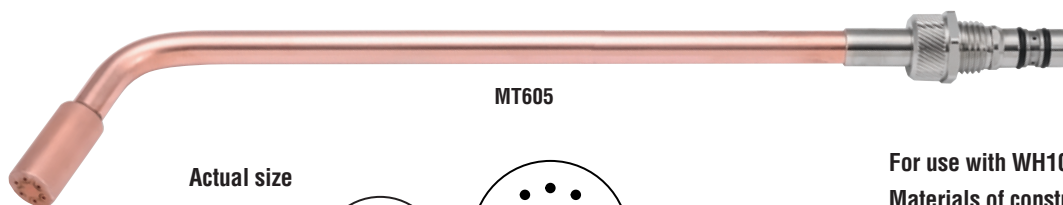

MT605

Actual size

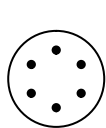

MT603

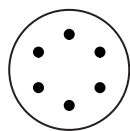

MT605

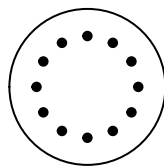

MT610

For use with WH100 medium-duty torch handle.

Materials of construction

- Head: copper
- Tube: copper
- Nut: nickel-plated brass
- Mixing section: nickel-plated brass
- O-rings: Buna-N

Gas Service	Stock No.	Average Btu/Hour	Pressure (psig)		Gas Consumption (scfh)		Drill Size	Overall Length	350 Cubic Foot Fuel Cylinders Required
			Oxygen	Acetylene	Oxygen	Acetylene			
Acetylene	MT603	41,160	15	15	31	28	64	10 in. (254 mm)	1
	MT605	74,970	15	15	57	51	56	16 in. (406 mm)	1
	MT610	132,300	15	15	100	90	57	18 in. (457 mm)	2

MT805 and MT615 Medium-Duty Heating Tips (Propane/Natural Gas/Propylene)

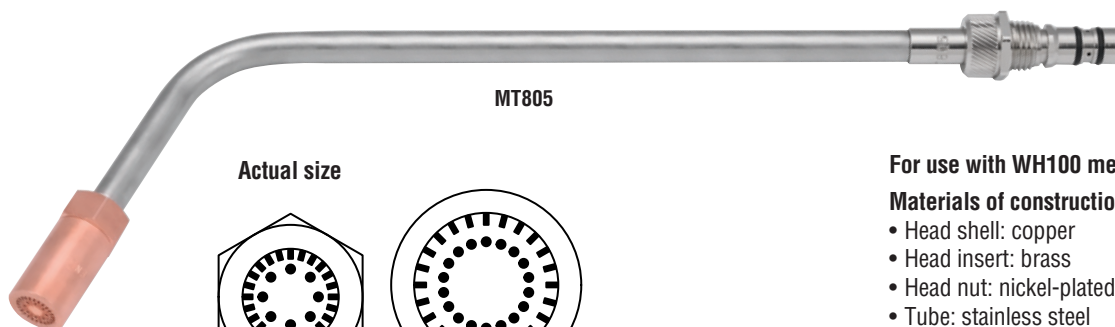

MT805

Actual size

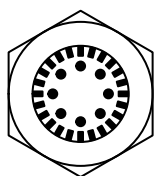

MT805

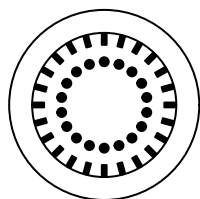

MT615

For use with WH100 medium-duty torch handle.

Materials of construction

- Head shell: copper
- Head insert: brass
- Head nut: nickel-plated brass
- Tube: stainless steel
- Nut: nickel-plated brass
- Mixing section: nickel-plated brass
- O-rings: Buna-N

Gas Service	Stock No.	Average Btu/Hour	Pressure (psig)		Gas Consumption (scfh)		Overall Length	Head Number
			Oxygen	Fuel Gas	Oxygen	Fuel Gas		
Propane/ natural gas	MT805	208,000	50-60	20-25 (propane)	206-230	80-100 (propane)	14 in. (356 mm)	4642
	MT615	269,000	20-60	10-25 (propane)	225-535	70-160 (propane)		14 in. (356 mm)
		182,000	15-50	10-25 (natural gas)	175-450	96-267 (natural gas)		
Propylene	MT805	280,000	50-60	20-25 (propylene)	242-270	120-135 (propylene)	14 in. (356 mm)	4642
	MT615	280,000	20-60	10-25 (propylene)	235-430	100-160 (propylene)	14 in. (356 mm)	1495

AT605 Standard-Duty Heating Tip (Acetylene)



For use with AW1A standard-duty torch handle.

Materials of construction

- Head: copper
- Tube: copper
- Nut: nickel-plated brass
- Mixing section: nickel-plated brass
- O-rings: Buna-N

Gas Service	Stock No.	Average Btu/Hour	Pressure (psig)		Gas Consumption (scfh)		Drill Size	Overall Length	200 Cubic Foot Fuel Cylinders Required
			Oxygen	Acetylene	Oxygen	Acetylene			
Acetylene	AT605	42,630	15	15	32	29	64	10 in. (254 mm)	1

AT60 Standard-Duty Heating Tip (Acetylene)

Actual size

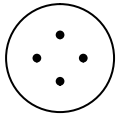

For use with AW1A standard-duty torch handle.

AT60 materials of construction

- Tube: copper
- Nut: nickel-plated brass
- Mixing section: nickel-plated brass
- O-rings: Buna-N

13716 materials of construction

- Outer sheel: copper
- Insert: brass

LT100 series materials of construction

- Brass



Gas Service	Stock No.	Tip End	Average Btu/Hour	Pressure (psig)		Gas Consumption (scfh)		Overall Length (not including tip end)
				Oxygen	Acetylene	Oxygen	Acetylene	
Acetylene	AT60	13716	24,990	17	17	17	17	5.6 in. (142 mm)
		LT103	6,320	10	10	4.3	4.3	
		LT104	13,230	10	10	9	9	
		LT106	24,990	10	10	17	17	

AT61 Standard-Duty Heating Tip (Propane/Natural Gas)

Actual size



For use with AW1A standard-duty torch handle.

AT61 materials of construction

- Tube: copper
- Nut: nickel-plated brass
- Mixing section: nickel-plated brass
- O-rings: Buna-N

13715 materials of construction

- Outer sheel: copper
- Insert: brass

NE154 materials of construction

- Brass



Gas Service	Stock No.	Tip End	Average Btu/Hour	Pressure (psig)		Gas Consumption (scfh)		Overall Length (not including tip end)
				Oxygen	Propane/Natural Gas	Oxygen	Propane/Natural Gas	
Propane/natural gas	AT61	13715	29,980	38	12	38	12	5.6 in. (142 mm)
		NE154	27,480	10	10	38	11	

AT600 and AT600X6 Standard-Duty Heating Tips (Acetylene/Propane/Natural Gas)



Actual size

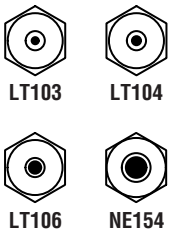

AT600 and AT600X6 Heating Tips			
Gas Service	Stock No.	Overall Length with Tip Ends	Tip Ends
Acetylene	AT600	13.8 in. (351 mm)	LT103, LT104, LT106
	AT600X6	9.8 in. (249 mm)	
Propane/natural gas	AT600	13.8 in. (351 mm)	NE154
	AT600X6	9.8 in. (249 mm)	

Note: Use LT100 series tip ends for acetylene (LT103 tip ends are included with AT600 and AT600X6) and NE154 tip ends for propane/natural gas (see chart below).

For use with AW1A standard-duty torch handle.

AT600 and AT600X6 materials of construction

- Tip nut: nickel-plated brass
- Tube: nickel-plated copper
- Mixing section: nickel-plated brass
- O-rings: Buna-N

LT100 series and NE154 materials of construction

- Brass

Gas Service	Stock No.	Btu per Hour	Pressure (psig)		Gas Consumption (scfh)		Brazing Capacity Copper Pipe Diameter	Drill Size
			Oxygen	Fuel Gas	Oxygen	Fuel Gas		
Acetylene	LT103	12,600	10	10 (acetylene)	8.6	8.6 (acetylene)	1/2–3/4 in. (12–19 mm)	63
	LT104	26,400	10	10 (acetylene)	18	18 (acetylene)	5/8–1 in. (16–25 mm)	56
	LT106	50,000	10	10 (acetylene)	34	34 (acetylene)	3/4–1-1/2 in. (19–38 mm)	52
Propane/natural gas	NE154	55,000	10	10 (propane/natural gas)	76	22 (propane/natural gas)	7/8–1-5/8 in. (22–41 mm)	36

Ordering Information

Heating Tips	Stock No.	Description	Qty.	Price
Heavy-Duty Heating Tips				
ST600 Series Heating Tips (for use with WH200A torch handle)	ST602	For acetylene, see page 2		
	ST603	For acetylene, see page 2		
	ST605	For acetylene, see page 2		
	ST610	For acetylene, see page 2		
	ST615	For propane/natural gas, see page 2		
	ST625	For propane/natural gas, see page 2		
	ST635	For propane, see page 2		
ST800 Series Heating Tips (for use with WH200A torch handle)	ST815	For propylene, see page 3		
	ST825	For propylene, see page 3		
SC Series Special-Purpose Tips (for use with cutting or machine torches)	SC83	For acetylene, see page 3		
	SC112	For propane, see page 3		
Medium-Duty Heating Tips				
MT600 Series Heating Tips (for use with WH100 torch handle)	MT603	For acetylene, see page 4		
	MT605	For acetylene, see page 4		
	MT610	For acetylene, see page 4		
	MT615	For propane/natural gas/propylene, see page 4		
MT805 Heating Tip (for use with WH100 torch handle)	MT805	For propane/natural gas/propylene, see page 4		
Standard-Duty Heating Tips				
AT Series Heating Tips (for use with AW1A torch handle)	AT605	For acetylene, see page 5		
	AT60	For acetylene, see page 5		
	AT61	For propane/natural gas, see page 5		
	AT600	For acetylene/propane/natural gas, see page 6		
	AT600X6	For acetylene/propane/natural gas, see page 6		
Replacement Parts				
Tip Ends	LT103	For acetylene, see page 6		
	LT104	For acetylene, see page 6		
	LT106	For acetylene, see page 6		
	NE154	For propane/natural gas, see page 6		

Date:

Total Quoted Price:

Distributed by:

