

# Series 31

## Medium-Duty Single-Stage Flow Gauge Regulators

### Quick Specs

#### Applications

Welding services  
Heavy fabrication  
Manufacturing  
Shipbuilding

#### Processes

MIG (GMAW)  
TIG (GTAW)

**Gas Service** Argon, argon/CO<sub>2</sub> mix, CO<sub>2</sub>

**Flow Range** 10–50 scfh (5–25 lpm)

**Max. Inlet Pressure** 3,000 psig (207 bar)

**Outlet Connection** 5/8"-18 RH internal

**CGA Inlet Connection** 320 or 580

**Regulator Body Inlet** 1/4" NPT

**Temperature Range** -20°–+140°F (-29°–+60°C)

Compact, precise flow control. Reliable for daily use.



31-50-580



Sure Seat™

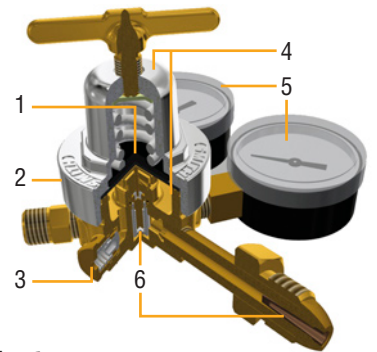

### Features

- 1. Neoprene composite diaphragm** resists corrosion for extended service life.
- 2. Color-coded labels** supply performance capabilities, easy gas service identification and technical information.
- 3. External relief valve** protects regulator from damage due to inadvertent high-pressure surge. Relief valve will release excessive pressure and automatically reset.
- 4. Brass body and nickel-plated bonnet** protect against corrosion.
- 5. Easy-to-read 2-inch gauges with shatter-resistant polycarbonate lens covers.**
- 6. Dual filters including Sure Seat** protect high-pressure seat from debris for reliable operation and long service life.



Warrantied for three years, parts and labor.



Underwriters Laboratories (UL) Listed



#### Miller Electric Mfg. LLC

An ITW Welding Company  
1635 West Spencer Street  
P.O. Box 1079  
Appleton, WI 54912-1079 USA

#### Equipment Sales US and Canada

Phone: 866-931-9730  
FAX: 800-637-2315  
International Phone: 920-735-4554  
International FAX: 920-735-4125

#### MillerWelds.com



## Performance Data

These flow charts are used to determine whether or not your regulator has the flow capability necessary for your application.

### How to use a flow chart:

There are multiple ways to use a flow chart. Each method relies on a pair of known values for inlet pressure, outlet pressure, or flow rate to determine the third. For example, if the inlet and outlet pressures are known and you wish to know the flow rate, the following steps may be used:

1. Identify curve corresponding to the system's inlet pressure. Different colors or symbols may be used to differentiate one inlet pressure from another.
2. Find desired outlet pressure on vertical axis.
3. Move horizontally across the chart until the line corresponding to the desired outlet pressure intersects the curve corresponding to the inlet pressure.
4. Read the flow rate marked along the horizontal axis.

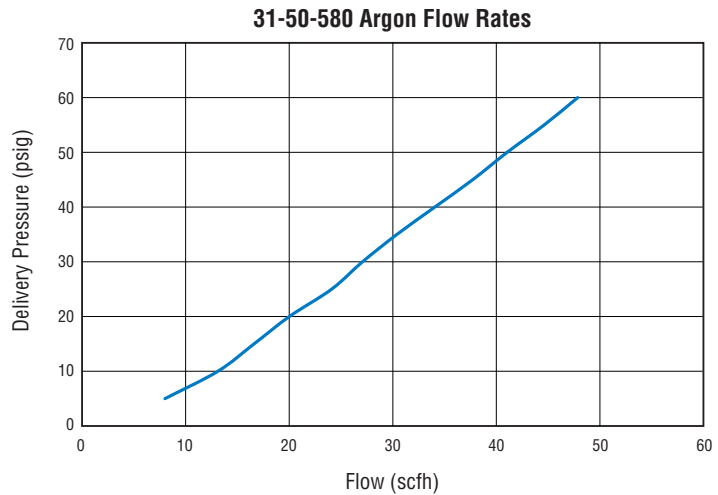

## Ordering Information

Stock No.	Gas Service	Inlet Gauge	Outlet Gauge	Flow Range	Max. Inlet Pressure	Outlet Connection	Inlet Connection
<b>Flow Gauge Regulators</b>							
31-50-580	Argon, argon/CO <sub>2</sub> mix	0–4,000 psig (0–280 bar)	0–50 scfh (0–25 lpm)	10–50 scfh (5–25 lpm)	3,000 psig (207 bar)	5/8"-18 RH internal	CGA 580
31-50-580-6*							CGA 320
31-50-320	CO <sub>2</sub>						

\*Flow gauge regulator with 6-feet x 1/4-inch inert hose and fittings.

Distributed by:

