

# WELDING POSITIONS



The standardized alphanumeric system shown below is used to specify a fillet weld or a groove weld, and whether the weld is to take place in the flat, horizontal, vertical or overhead position. Knowing this alphanumeric system will help you make the right weld every time.

## Fillet Weld

## Groove Weld

Flat Position

>> 1F

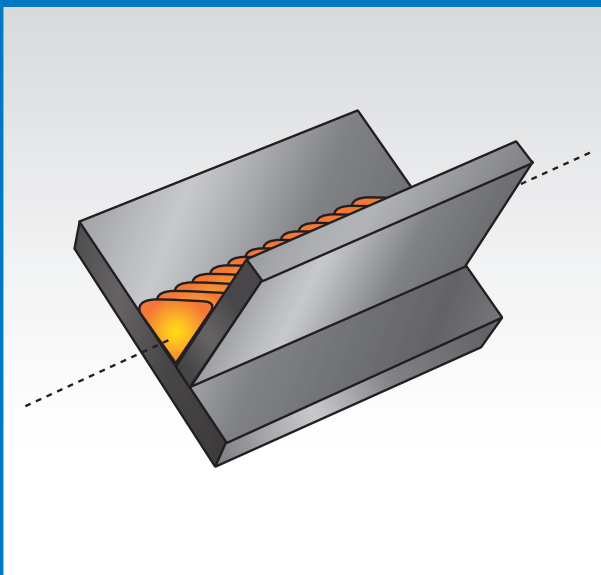

>> 1G

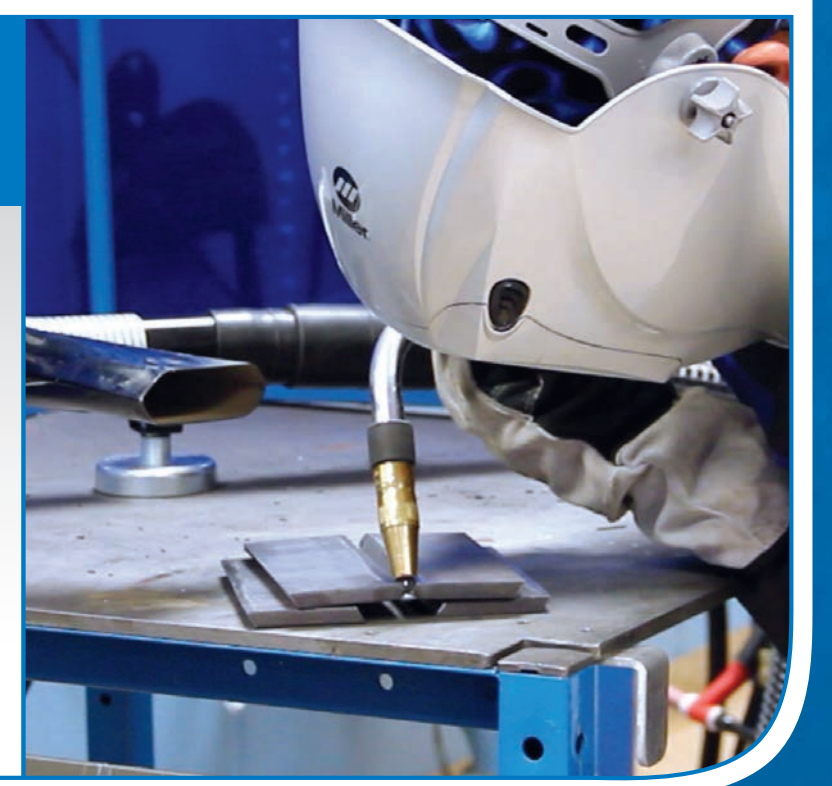
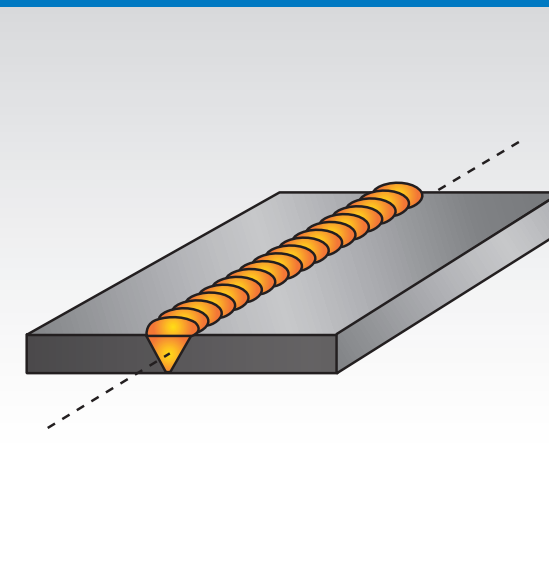

Horizontal Position

>> 2F

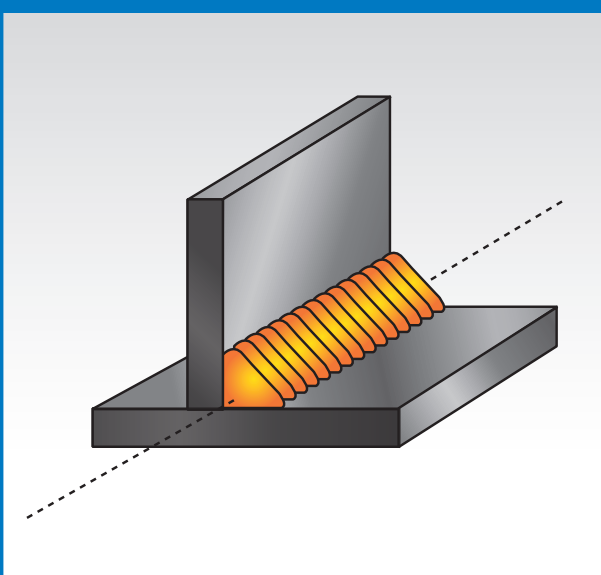

>> 2G

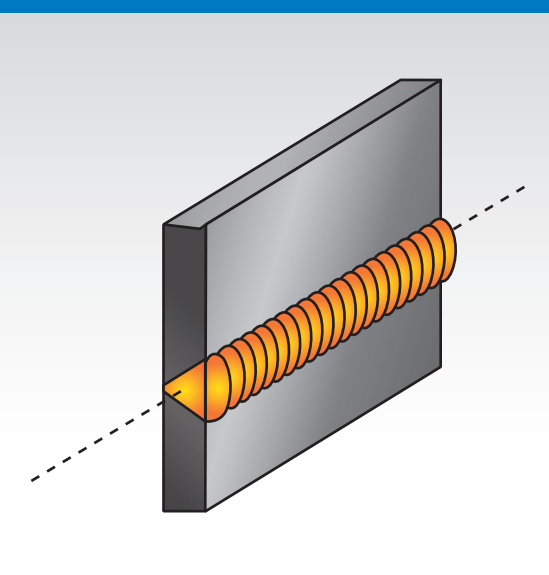

Vertical Position

>> 3F

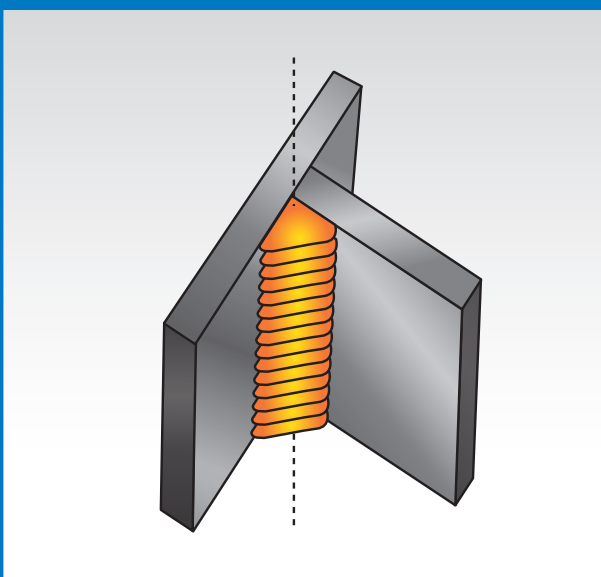

>> 3G

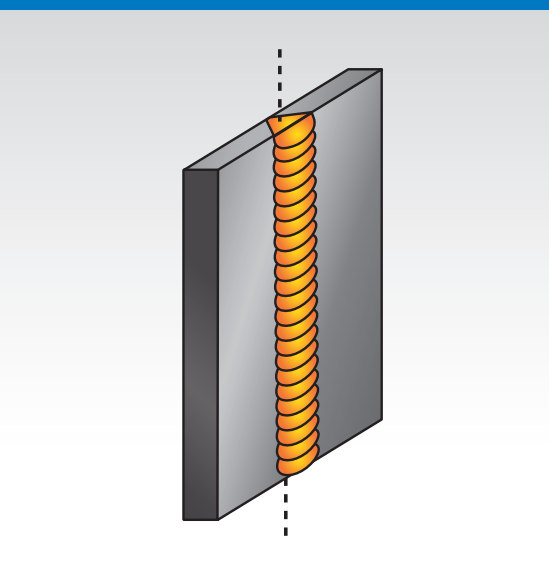

Overhead Position

>> 4F

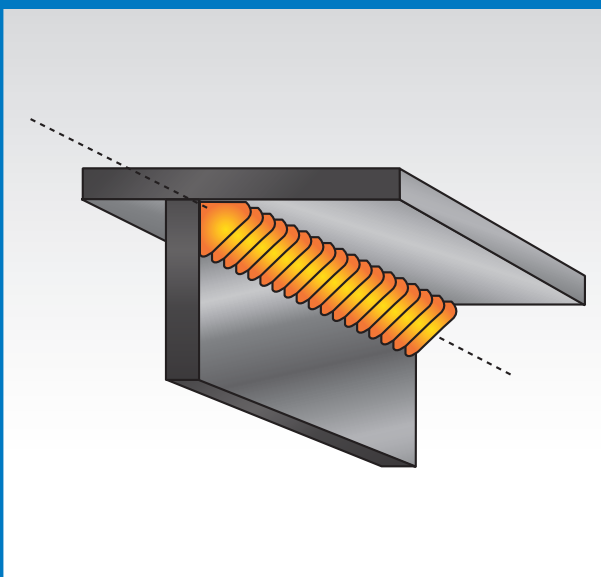

>> 4G

