



OM-1320

196 846G

September 2001

Processes



MIG (GMAW) Welding

Flux Cored (FCAW) Welding

Description



Arc Welding Power Source
and Wire Feeder

Millermatic[®] 250X

With Meters

And M-25 Gun

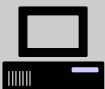
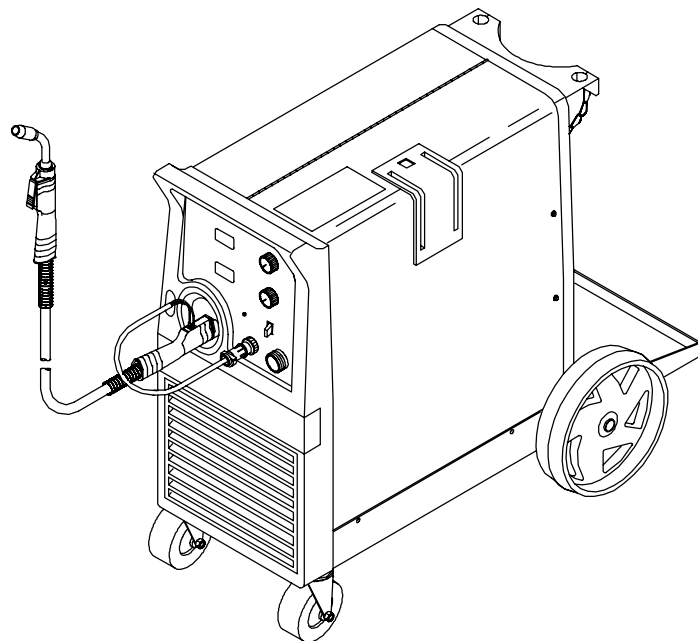

Visit our website at
www.MillerWelds.com

OWNER'S MANUAL

MANUAL DEL OPERADOR

(cuando disponible) sigue al manual en inglés

From Miller to You

Thank you and congratulations on choosing Miller. Now you can get the job done and get it done right. We know you don't have time to do it any other way.

That's why when Niels Miller first started building arc welders in 1929, he made sure his products offered long-lasting value and superior quality. Like you, his customers couldn't afford anything less. Miller products had to be more than the best they could be. They had to be the best you could buy.



Today, the people that build and sell Miller products continue the tradition. They're just as committed to providing equipment and service that meets the high standards of quality and value established in 1929.

This Owner's Manual is designed to help you get the most out of your Miller products. Please take time to read the Safety precautions. They will help you protect yourself against potential hazards on the worksite.



Miller is the first welding equipment manufacturer in the U.S.A. to be registered to the ISO 9001 Quality System Standard.

We've made installation and operation quick and easy. With Miller you can count on years of reliable service with proper maintenance. And if for some reason the unit needs repair, there's a Troubleshooting section that will help you figure out what the problem is. The parts list will then help you to decide which exact part you may need to fix the problem. Warranty and service information for your particular model are also provided.



Miller Electric manufactures a full line of welders and welding related equipment. For information on other quality Miller products, contact your local Miller distributor to receive the latest full line catalog or individual catalog sheets. **To locate your nearest distributor or service agency call 1-800-4-A-Miller, or visit us at www.MillerWelds.com on the web.**



Working as hard as you do – every power source from Miller is backed by the most hassle-free warranty in the business.

Miller offers a *Technical Manual* which provides more detailed service and parts information for your unit. To obtain a *Technical Manual*, contact your local distributor. Your distributor can also supply you with *Welding Process Manuals* such as SMAW, GTAW, GMAW, and GMAW-P.



TABLE OF CONTENTS

WARNING

This product, when used for welding or cutting, produces fumes or gases which contain chemicals known to the State of California to cause birth defects and, in some cases, cancer. (California Health & Safety Code Section 25249.5 et seq.)

The following terms are used interchangeably throughout this manual:
MIG = GMAW

SECTION 1 – SAFETY PRECAUTIONS - READ BEFORE USING	1
1-1. Symbol Usage	1
1-2. Arc Welding Hazards	1
1-3. Additional Symbols For Installation, Operation, And Maintenance	3
1-4. Principal Safety Standards	3
1-5. EMF Information	4
SECTION 1 – CONSIGNES DE SECURITE – LIRE AVANT UTILISATION	5
1-1. Signification des symboles	5
1-2. Dangers relatifs au soudage à l'arc	5
1-3. Dangers supplémentaires en relation avec l'installation, le fonctionnement et la maintenance	7
1-4. Principales normes de sécurité	8
1-5. Information sur les champs électromagnétiques	8
SECTION 2 – INSTALLATION	9
2-1. Specifications	9
2-2. Welding Power Source Duty Cycle And Overheating	9
2-3. Welding Gun Duty Cycle And Overheating	10
2-4. Volt-Ampere Curves	10
2-5. Installing Work Clamp	11
2-6. Installing Welding Gun	11
2-7. Connecting A Spoolmatic 30A Gun	11
2-8. Setting Gun Polarity For Wire Type	12
2-9. Installing Gas Supply	12
2-10. Installing Wire Spool and Adjusting Hub Tension	13
2-11. Positioning Jumper Links	13
2-12. Electrical Service Guide	14
2-13. Selecting A Location And Connecting Input Power	14
2-14. Threading Welding Wire	15
2-15. Weld Parameter	16
2-16. Using Gun/Cable Holder	18
SECTION 3 – OPERATION	19
3-1. Controls	19
3-2. Voltmeter And Wire Feed Speed Meter Operation	20
SECTION 4 – MAINTENANCE & TROUBLESHOOTING	21
4-1. Routine Maintenance	21
4-2. Circuit Breaker CB1	21
4-3. Unit Overload	21
4-4. Replacing Gun Contact Tip	22
4-5. Changing Drive Roll and Wire Inlet Guide	22
4-6. Aligning Drive Rolls and Wire Guide	23
4-7. Cleaning Or Replacing Gun Liner	24
4-8. Replacing Switch And/Or Head Tube	25
4-9. Troubleshooting	26
SECTION 5 – ELECTRICAL DIAGRAM	27
SECTION 6 – PARTS LIST	28
WARRANTY	

SECTION 1 – SAFETY PRECAUTIONS - READ BEFORE USING

som_nd_4/98

1-1. Symbol Usage



Means Warning! Watch Out! There are possible hazards with this procedure! The possible hazards are shown in the adjoining symbols.

▲ Marks a special safety message.

☞ Means "Note"; not safety related.



This group of symbols means Warning! Watch Out! possible ELECTRIC SHOCK, MOVING PARTS, and HOT PARTS hazards. Consult symbols and related instructions below for necessary actions to avoid the hazards.

1-2. Arc Welding Hazards

▲ The symbols shown below are used throughout this manual to call attention to and identify possible hazards. When you see the symbol, watch out, and follow the related instructions to avoid the hazard. The safety information given below is only a summary of the more complete safety information found in the Safety Standards listed in Section 1-4. Read and follow all Safety Standards.

▲ Only qualified persons should install, operate, maintain, and repair this unit.

▲ During operation, keep everybody, especially children, away.



ELECTRIC SHOCK can kill.

Touching live electrical parts can cause fatal shocks or severe burns. The electrode and work circuit is electrically live whenever the output is on. The input power circuit and machine internal circuits are also

live when power is on. In semiautomatic or automatic wire welding, the wire, wire reel, drive roll housing, and all metal parts touching the welding wire are electrically live. Incorrectly installed or improperly grounded equipment is a hazard.

- Do not touch live electrical parts.
- Wear dry, hole-free insulating gloves and body protection.
- Insulate yourself from work and ground using dry insulating mats or covers big enough to prevent any physical contact with the work or ground.
- Do not use AC output in damp areas, if movement is confined, or if there is a danger of falling.
- Use AC output ONLY if required for the welding process.
- If AC output is required, use remote output control if present on unit.
- Disconnect input power or stop engine before installing or servicing this equipment. Lockout/tagout input power according to OSHA 29 CFR 1910.147 (see Safety Standards).
- Properly install and ground this equipment according to its Owner's Manual and national, state, and local codes.
- Always verify the supply ground – check and be sure that input power cord ground wire is properly connected to ground terminal in disconnect box or that cord plug is connected to a properly grounded receptacle outlet.
- When making input connections, attach proper grounding conductor first – double-check connections.
- Frequently inspect input power cord for damage or bare wiring – replace cord immediately if damaged – bare wiring can kill.
- Turn off all equipment when not in use.
- Do not use worn, damaged, undersized, or poorly spliced cables.
- Do not drape cables over your body.

- If earth grounding of the workpiece is required, ground it directly with a separate cable.
- Do not touch electrode if you are in contact with the work, ground, or another electrode from a different machine.
- Use only well-maintained equipment. Repair or replace damaged parts at once. Maintain unit according to manual.
- Wear a safety harness if working above floor level.
- Keep all panels and covers securely in place.
- Clamp work cable with good metal-to-metal contact to workpiece or worktable as near the weld as practical.
- Insulate work clamp when not connected to workpiece to prevent contact with any metal object.
- Do not connect more than one electrode or work cable to any single weld output terminal.

SIGNIFICANT DC VOLTAGE exists after removal of input power on inverters.

- Turn Off inverter, disconnect input power, and discharge input capacitors according to instructions in Maintenance Section before touching any parts.

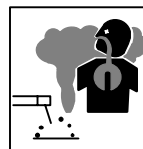

FUMES AND GASES can be hazardous.

Welding produces fumes and gases. Breathing these fumes and gases can be hazardous to your health.

- Keep your head out of the fumes. Do not breathe the fumes.
- If inside, ventilate the area and/or use exhaust at the arc to remove welding fumes and gases.
- If ventilation is poor, use an approved air-supplied respirator.
- Read the Material Safety Data Sheets (MSDSs) and the manufacturer's instructions for metals, consumables, coatings, cleaners, and degreasers.
- Work in a confined space only if it is well ventilated, or while wearing an air-supplied respirator. Always have a trained watch-person nearby. Welding fumes and gases can displace air and lower the oxygen level causing injury or death. Be sure the breathing air is safe.
- Do not weld in locations near degreasing, cleaning, or spraying operations. The heat and rays of the arc can react with vapors to form highly toxic and irritating gases.
- Do not weld on coated metals, such as galvanized, lead, or cadmium plated steel, unless the coating is removed from the weld area, the area is well ventilated, and if necessary, while wearing an air-supplied respirator. The coatings and any metals containing these elements can give off toxic fumes if welded.



ARC RAYS can burn eyes and skin.

Arc rays from the welding process produce intense visible and invisible (ultraviolet and infrared) rays that can burn eyes and skin. Sparks fly off from the weld.

- Wear a welding helmet fitted with a proper shade of filter to protect your face and eyes when welding or watching (see ANSI Z49.1 and Z87.1 listed in Safety Standards).
- Wear approved safety glasses with side shields under your helmet.
- Use protective screens or barriers to protect others from flash and glare; warn others not to watch the arc.
- Wear protective clothing made from durable, flame-resistant material (leather and wool) and foot protection.



WELDING can cause fire or explosion.

Welding on closed containers, such as tanks, drums, or pipes, can cause them to blow up. Sparks can fly off from the welding arc. The flying sparks, hot workpiece, and hot equipment can cause fires and burns. Accidental contact of electrode to metal objects can cause sparks, explosion, overheating, or fire. Check and be sure the area is safe before doing any welding.

- Protect yourself and others from flying sparks and hot metal.
- Do not weld where flying sparks can strike flammable material.
- Remove all flammables within 35 ft (10.7 m) of the welding arc. If this is not possible, tightly cover them with approved covers.
- Be alert that welding sparks and hot materials from welding can easily go through small cracks and openings to adjacent areas.
- Watch for fire, and keep a fire extinguisher nearby.
- Be aware that welding on a ceiling, floor, bulkhead, or partition can cause fire on the hidden side.
- Do not weld on closed containers such as tanks, drums, or pipes, unless they are properly prepared according to AWS F4.1 (see Safety Standards).
- Connect work cable to the work as close to the welding area as practical to prevent welding current from traveling long, possibly unknown paths and causing electric shock and fire hazards.
- Do not use welder to thaw frozen pipes.
- Remove stick electrode from holder or cut off welding wire at contact tip when not in use.
- Wear oil-free protective garments such as leather gloves, heavy shirt, cuffless trousers, high shoes, and a cap.
- Remove any combustibles, such as a butane lighter or matches, from your person before doing any welding.

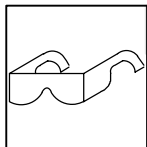

FLYING METAL can injure eyes.

- Welding, chipping, wire brushing, and grinding cause sparks and flying metal. As welds cool, they can throw off slag.
- Wear approved safety glasses with side shields even under your welding helmet.



BUILDUP OF GAS can injure or kill.

- Shut off shielding gas supply when not in use.
- Always ventilate confined spaces or use approved air-supplied respirator.



HOT PARTS can cause severe burns.

- Do not touch hot parts bare handed.
- Allow cooling period before working on gun or torch.

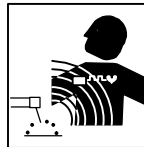

MAGNETIC FIELDS can affect pacemakers.

- Pacemaker wearers keep away.
- Wearers should consult their doctor before going near arc welding, gouging, or spot welding operations.

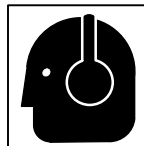

NOISE can damage hearing.

Noise from some processes or equipment can damage hearing.

- Wear approved ear protection if noise level is high.

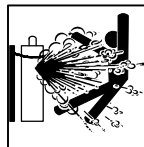

CYLINDERS can explode if damaged.

Shielding gas cylinders contain gas under high pressure. If damaged, a cylinder can explode. Since gas cylinders are normally part of the welding process, be sure to treat them carefully.

- Protect compressed gas cylinders from excessive heat, mechanical shocks, slag, open flames, sparks, and arcs.
- Install cylinders in an upright position by securing to a stationary support or cylinder rack to prevent falling or tipping.
- Keep cylinders away from any welding or other electrical circuits.
- Never drape a welding torch over a gas cylinder.
- Never allow a welding electrode to touch any cylinder.
- Never weld on a pressurized cylinder – explosion will result.
- Use only correct shielding gas cylinders, regulators, hoses, and fittings designed for the specific application; maintain them and associated parts in good condition.
- Turn face away from valve outlet when opening cylinder valve.
- Keep protective cap in place over valve except when cylinder is in use or connected for use.
- Read and follow instructions on compressed gas cylinders, associated equipment, and CGA publication P-1 listed in Safety Standards.

1-3. Additional Symbols For Installation, Operation, And Maintenance



FIRE OR EXPLOSION hazard.

- Do not install or place unit on, over, or near combustible surfaces.
- Do not install unit near flammables.
- Do not overload building wiring – be sure power supply system is properly sized, rated, and protected to handle this unit.



MOVING PARTS can cause injury.

- Keep away from moving parts such as fans.
- Keep all doors, panels, covers, and guards closed and securely in place.



FALLING UNIT can cause injury.

- Use lifting eye to lift unit only, NOT running gear, gas cylinders, or any other accessories.
- Use equipment of adequate capacity to lift and support unit.
- If using lift forks to move unit, be sure forks are long enough to extend beyond opposite side of unit.

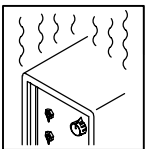

OVERUSE can cause OVERHEATING

- Allow cooling period; follow rated duty cycle.
- Reduce current or reduce duty cycle before starting to weld again.
- Do not block or filter airflow to unit.

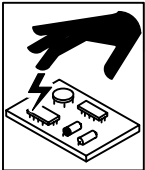

STATIC (ESD) can damage PC boards.

- Put on grounded wrist strap BEFORE handling boards or parts.
- Use proper static-proof bags and boxes to store, move, or ship PC boards.



MOVING PARTS can cause injury.

- Keep away from moving parts.
- Keep away from pinch points such as drive rolls.



WELDING WIRE can cause injury.

- Do not press gun trigger until instructed to do so.
- Do not point gun toward any part of the body, other people, or any metal when threading welding wire.

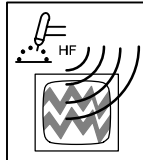

H.F. RADIATION can cause interference.

- High-frequency (H.F.) can interfere with radio navigation, safety services, computers, and communications equipment.
- Have only qualified persons familiar with electronic equipment perform this installation.
- The user is responsible for having a qualified electrician promptly correct any interference problem resulting from the installation.
- If notified by the FCC about interference, stop using the equipment at once.
- Have the installation regularly checked and maintained.
- Keep high-frequency source doors and panels tightly shut, keep spark gaps at correct setting, and use grounding and shielding to minimize the possibility of interference.

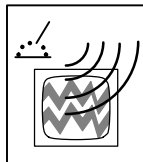

ARC WELDING can cause interference.

- Electromagnetic energy can interfere with sensitive electronic equipment such as computers and computer-driven equipment such as robots.
- Be sure all equipment in the welding area is electromagnetically compatible.
- To reduce possible interference, keep weld cables as short as possible, close together, and down low, such as on the floor.
- Locate welding operation 100 meters from any sensitive electronic equipment.
- Be sure this welding machine is installed and grounded according to this manual.
- If interference still occurs, the user must take extra measures such as moving the welding machine, using shielded cables, using line filters, or shielding the work area.

1-4. Principal Safety Standards

Safety in Welding and Cutting, ANSI Standard Z49.1, from American Welding Society, 550 N.W. LeJeune Rd, Miami FL 33126

Safety and Health Standards, OSHA 29 CFR 1910, from Superintendent of Documents, U.S. Government Printing Office, Washington, D.C. 20402.

Recommended Safe Practices for the Preparation for Welding and Cutting of Containers That Have Held Hazardous Substances, American Welding Society Standard AWS F4.1, from American Welding Society, 550 N.W. LeJeune Rd, Miami, FL 33126

National Electrical Code, NFPA Standard 70, from National Fire Protection Association, Batterymarch Park, Quincy, MA 02269.

Safe Handling of Compressed Gases in Cylinders, CGA Pamphlet P-1, from Compressed Gas Association, 1235 Jefferson Davis Highway, Suite 501, Arlington, VA 22202.

Code for Safety in Welding and Cutting, CSA Standard W117.2, from Canadian Standards Association, Standards Sales, 178 Rexdale Boulevard, Rexdale, Ontario, Canada M9W 1R3.

Safe Practices For Occupation And Educational Eye And Face Protection, ANSI Standard Z87.1, from American National Standards Institute, 1430 Broadway, New York, NY 10018.

Cutting And Welding Processes, NFPA Standard 51B, from National Fire Protection Association, Batterymarch Park, Quincy, MA 02269.

1-5. EMF Information

Considerations About Welding And The Effects Of Low Frequency Electric And Magnetic Fields

Welding current, as it flows through welding cables, will cause electromagnetic fields. There has been and still is some concern about such fields. However, after examining more than 500 studies spanning 17 years of research, a special blue ribbon committee of the National Research Council concluded that: "The body of evidence, in the committee's judgment, has not demonstrated that exposure to power-frequency electric and magnetic fields is a human-health hazard." However, studies are still going forth and evidence continues to be examined. Until the final conclusions of the research are reached, you may wish to minimize your exposure to electromagnetic fields when welding or cutting.

To reduce magnetic fields in the workplace, use the following procedures:

1. Keep cables close together by twisting or taping them.
2. Arrange cables to one side and away from the operator.
3. Do not coil or drape cables around your body.
4. Keep welding power source and cables as far away from operator as practical.
5. Connect work clamp to workpiece as close to the weld as possible.

About Pacemakers:

Pacemaker wearers consult your doctor first. If cleared by your doctor, then following the above procedures is recommended.

SECTION 1 – CONSIGNES DE SECURITE – LIRE AVANT UTILISATION

som _nd_fre 4/98

1-1. Signification des symboles



Signifie Mise en garde ! Soyez vigilant ! Cette procédure présente des risques de danger ! Ceux-ci sont identifiés par des symboles adjacents aux directives.

▲ Identifie un message de sécurité particulier.

Signifie NOTA ; n'est pas relatif à la sécurité.



Ce groupe de symboles signifie Mise en garde ! Soyez vigilant ! Il y a des risques de danger reliés aux CHOCS ÉLECTRIQUES, aux PIÈCES EN MOUVEMENT et aux PIÈCES CHAUDES. Reportez-vous aux symboles et aux directives ci-dessous afin de connaître les mesures à prendre pour éviter tout danger.

1-2. Dangers relatifs au soudage à l'arc

▲ Les symboles présentés ci-après sont utilisés tout au long du présent manuel pour attirer votre attention et identifier les risques de danger. Lorsque vous voyez un symbole, soyez vigilant et suivez les directives mentionnées afin d'éviter tout danger. Les consignes de sécurité présentées ci-après ne font que résumer l'information contenue dans les normes de sécurité énumérées à la section 1-4. Veuillez lire et respecter toutes ces normes de sécurité.

▲ L'installation, l'utilisation, l'entretien et les réparations ne doivent être confiés qu'à des personnes qualifiées.

▲ Au cours de l'utilisation, tenir toute personne à l'écart et plus particulièrement les enfants.



UN CHOC ÉLECTRIQUE peut tuer.

Un simple contact avec des pièces électriques peut provoquer une électrocution ou des blessures graves. L'électrode et le circuit de soudage sont sous tension dès que l'appareil est sur ON. Le circuit d'entrée et les circuits internes de l'appareil sont également sous tension à ce moment-là. En soudage semi-automatique ou automatique, le fil, le dévidoir, le logement des galets d'entraînement et les pièces métalliques en contact avec le fil de soudage sont sous tension. Des matériels mal installés ou mal mis à la terre présentent un danger.

- Ne jamais toucher les pièces électriques sous tension.
- Porter des gants et des vêtements de protection secs ne comportant pas de trous.
- S'isoler de la pièce et de la terre au moyen de tapis ou d'autres moyens isolants suffisamment grands pour empêcher le contact physique éventuel avec la pièce ou la terre.
- Ne pas se servir de source électrique à courant électrique dans les zones humides, dans les endroits confinés ou là où on risque de tomber.
- Se servir d'une source électrique à courant électrique UNIQUEMENT si le procédé de soudage le demande.
- Si l'utilisation d'une source électrique à courant électrique s'avère nécessaire, se servir de la fonction de télécommande si l'appareil en est équipé.
- Couper l'alimentation ou arrêter le moteur avant de procéder à l'installation, à la réparation ou à l'entretien de l'appareil. Déverrouiller l'alimentation selon la norme OSHA 29 CFR 1910.147 (voir normes de sécurité).
- Installer et mettre à la terre correctement cet appareil conformément à son manuel d'utilisation et aux codes nationaux, provinciaux et municipaux.
- Toujours vérifier la terre du cordon d'alimentation – Vérifier et s'assurer que le fil de terre du cordon d'alimentation est bien raccordé à la borne de terre du sectionneur ou que la fiche du cordon est raccordée à une prise correctement mise à la terre.
- En effectuant les raccordements d'entrée fixer d'abord le conducteur de mise à la terre approprié et contre-vérifier les connexions.
- Vérifier fréquemment le cordon d'alimentation pour voir s'il n'est pas endommagé ou dénudé – remplacer le cordon immédiatement s'il est endommagé – un câble dénudé peut provoquer une électrocution.
- Mettre l'appareil hors tension quand on ne l'utilise pas.
- Ne pas utiliser des câbles usés, endommagés, de grosseur insuffisante ou mal épissés.
- Ne pas enrouler les câbles autour du corps.
- Si la pièce soudée doit être mise à la terre, le faire directement avec un câble distinct.
- Ne pas toucher l'électrode quand on est en contact avec la pièce, la terre ou une électrode provenant d'une autre machine.

- N'utiliser qu'un matériel en bon état. Réparer ou remplacer sur-le-champ les pièces endommagées. Entretien l'appareil conformément à ce manuel.
- Porter un harnais de sécurité quand on travaille en hauteur.
- Maintenir solidement en place tous les panneaux et capots.
- Fixer le câble de retour de façon à obtenir un bon contact métal-métal avec la pièce à souder ou la table de travail, le plus près possible de la soudure.
- Isoler la pince de masse quand pas mis à la pièce pour éviter le contact avec tout objet métallique.

Il y a DU COURANT CONTINU IMPORTANT dans les convertisseurs après la suppression de l'alimentation électrique.

- Arrêter les convertisseurs, débrancher le courant électrique, et décharger les condensateurs d'alimentation selon les instructions indiquées dans la partie entretien avant de toucher les pièces.

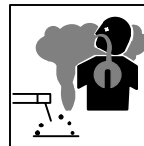

LES FUMÉES ET LES GAZ peuvent être dangereux.

Le soudage génère des fumées et des gaz. Leur inhalation peut être dangereuse pour votre santé.

- Eloigner votre tête des fumées. Ne pas respirer les fumées.
- A l'intérieur, ventiler la zone et/ou utiliser un échappement au niveau de l'arc pour l'évacuation des fumées et des gaz de soudage.
- Si la ventilation est insuffisante, utiliser un respirateur à alimentation d'air homologué.
- Lire les spécifications de sécurité des matériaux (MSDSs) et les instructions du fabricant concernant les métaux, les consommables, les revêtements, les nettoyants et les dégraissants.
- Travailler dans un espace fermé seulement s'il est bien ventilé ou en portant un respirateur à alimentation d'air. Demander toujours à un surveillant dûment formé de se tenir à proximité. Des fumées et des gaz de soudage peuvent déplacer l'air et abaisser le niveau d'oxygène provoquant des blessures ou des accidents mortels. S'assurer que l'air de respiration ne présente aucun danger.
- Ne pas souder dans des endroits situés à proximité d'opérations de dégraissage, de nettoyage ou de pulvérisation. La chaleur et les rayons de l'arc peuvent réagir en présence de vapeurs et former des gaz hautement toxiques et irritants.
- Ne pas souder des métaux munis d'un revêtement, tels que l'acier galvanisé, plaqué en plomb ou au cadmium à moins que le revêtement n'ait été enlevé dans la zone de soudure, que l'endroit soit bien ventilé, et si nécessaire, en portant un respirateur à alimentation d'air. Les revêtements et tous les métaux renfermant ces éléments peuvent dégager des fumées toxiques en cas de soudage.



LES RAYONS DE L'ARC peuvent provoquer des brûlures dans les yeux et sur la peau.

Le rayonnement de l'arc du procédé de soudage génère des rayons visibles et invisibles intenses (ultraviolets et infrarouges) susceptibles de provoquer des brûlures dans les yeux et sur la peau. Des étincelles sont projetées pendant le soudage.

- Porter un casque de soudage muni d'un écran de filtre approprié pour protéger votre visage et vos yeux pendant le soudage ou pour regarder (voir ANSI Z49.1 et Z87.1 énuméré dans les normes de sécurité).
- Porter des protections approuvés pour les oreilles si le niveau sonore est trop élevé.
- Utiliser des écrans ou des barrières pour protéger des tiers de l'éclair et de l'éblouissement; demander aux autres personnes de ne pas regarder l'arc.
- Porter des vêtements de protection constitué dans une matière durable, résistant au feu (cuir ou laine) et une protection des pieds.



LE SOUDAGE peut provoquer un incendie ou une explosion.

Le soudage effectué sur des conteneurs fermés tels que des réservoirs, tambours ou des conduites peut provoquer leur éclatement. Des étincelles peuvent être projetées de l'arc de soudure. La projection d'étincelles, des pièces chaudes et des équipements chauds peut provoquer des incendies et des brûlures. Le contact accidentel de l'électrode avec des objets métalliques peut provoquer des étincelles, une explosion, un surchauffement ou un incendie. Avant de commencer le soudage, vérifier et s'assurer que l'endroit ne présente pas de danger.

- Se protéger et d'autres personnes de la projection d'étincelles et de métal chaud.
- Ne pas souder dans un endroit là où des étincelles peuvent tomber sur des substances inflammables.
- Déplacer toutes les substances inflammables à une distance de 10,7 m de l'arc de soudage. En cas d'impossibilité les recouvrir soigneusement avec des protections homologués.
- Des étincelles et des matériaux chauds du soudage peuvent facilement passer dans d'autres zones en traversant de petites fissures et des ouvertures.
- Surveiller tout déclenchement d'incendie et tenir un extincteur à proximité.
- Le soudage effectué sur un plafond, plancher, paroi ou séparation peut déclencher un incendie de l'autre côté.
- Ne pas effectuer le soudage sur des conteneurs fermés tels que des réservoirs, tambours, ou conduites, à moins qu'ils n'aient été préparés correctement conformément à AWS F4.1 (voir les normes de sécurité).
- Brancher le câble sur la pièce le plus près possible de la zone de soudage pour éviter le transport du courant sur une longue distance par des chemins inconnus éventuels en provoquant des risques d'électrocution et d'incendie.
- Ne pas utiliser le poste de soudage pour décongeler des conduites gelées.
- En cas de non utilisation, enlever la baguette d'électrode du porte-électrode ou couper le fil à la pointe de contact.
- Porter des vêtements de protection dépourvus d'huile tels que des gants en cuir, une chemise en matériau lourd, des pantalons sans revers, des chaussures hautes et un couvre chef.
- Avant de souder, retirer toute substance combustible de vos poches telles qu'un allumeur au butane ou des allumettes.

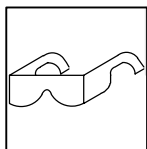

DES PARTICULES VOLANTES peuvent blesser les yeux.

- Le soudage, l'écaillage, le passage de la pièce à la brosse en fil de fer, et le meulage génèrent des étincelles et des particules métalliques volantes. Pendant la période de refroidissement des soudures, elles risquent de projeter du laitier.
- Porter des lunettes de sécurité avec écrans latéraux ou un écran facial.



LES ACCUMULATIONS DE GAZ risquent de provoquer des blessures ou même la mort.

- Fermer l'alimentation du gaz protecteur en cas de non utilisation.
- Veiller toujours à bien aérer les espaces confinés ou se servir d'un respirateur d'adduction d'air homologué.



DES PIÈCES CHAUDES peuvent provoquer des brûlures graves.

- Ne pas toucher des parties chaudes à mains nues
- Prévoir une période de refroidissement avant d'utiliser le pistolet ou la torche.

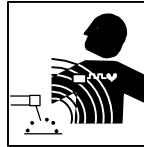

LES CHAMPS MAGNÉTIQUES peuvent affecter les stimulateurs cardiaques.

- Porteurs de stimulateur cardiaque, restez à distance.
- Les porteurs d'un stimulateur cardiaque doivent d'abord consulter leur médecin avant de s'approcher des opérations de soudage à l'arc, de gougeage ou de soudage par points.

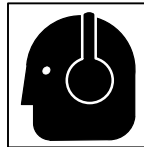

LE BRUIT peut affecter l'ouïe.

Le bruit des processus et des équipements peut affecter l'ouïe.

- Porter des protections approuvés pour les oreilles si le niveau sonore est trop élevé.

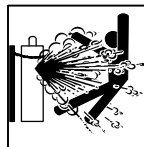

Si des BOUTEILLES sont endommagées, elles pourront exploser.

Des bouteilles de gaz protecteur contiennent du gaz sous haute pression. Si une bouteille est endommagée, elle peut exploser. Du fait que les bouteilles de gaz font normalement partie du procédé de soudage, les manipuler avec précaution.

- Protéger les bouteilles de gaz comprimé d'une chaleur excessive, des chocs mécaniques, du laitier, des flammes ouvertes, des étincelles et des arcs.
- Placer les bouteilles debout en les fixant dans un support stationnaire ou dans un porte-bouteilles pour les empêcher de tomber ou de se renverser.
- Tenir les bouteilles éloignées des circuits de soudage ou autres circuits électriques.
- Ne jamais placer une torche de soudage sur une bouteille à gaz.
- Une électrode de soudage ne doit jamais entrer en contact avec une bouteille.
- Ne jamais souder une bouteille pressurisée – risque d'explosion.
- Utiliser seulement des bouteilles de gaz protecteur, régulateurs, tuyaux et raccords convenables pour cette application spécifique; les maintenir ainsi que les éléments associés en bon état.
- Ne pas tenir la tête en face de la sortie en ouvrant la soupape de la bouteille.
- Maintenir le chapeau de protection sur la soupape, sauf en cas d'utilisation ou de branchement de la bouteille.
- Lire et suivre les instructions concernant les bouteilles de gaz comprimé, les équipements associés et les publications P-1 CGA énumérées dans les normes de sécurité.

1-3. Dangers supplémentaires en relation avec l'installation, le fonctionnement et la maintenance



Risque D'INCENDIE OU D'EXPLOSION.

- Ne pas placer l'appareil sur, au-dessus ou à proximité de surfaces inflammables.
- Ne pas installer l'appareil à proximité de produits inflammables
- Ne pas surcharger l'installation électrique – s'assurer que l'alimentation est correctement dimensionnée et protégée avant de mettre l'appareil en service.



LA CHUTE DE L'APPAREIL peut blesser.

- Utiliser l'anneau de levage uniquement pour soulever l'appareil, NON PAS les chariot, les bouteilles de gaz ou tout autre accessoire.
- Utiliser un engin d'une capacité appropriée pour soulever l'appareil.
- En utilisant des fourches de levage pour déplacer l'unité, s'assurer que les fourches sont suffisamment longues pour dépasser du côté opposé de l'appareil.

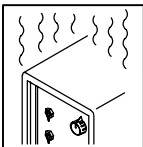

L'EMPLOI EXCESSIF peut SURCHAUFFER L'ÉQUIPEMENT.

- Prévoir une période de refroidissement, respecter le cycle opératoire nominal.
- Réduire le courant ou le cycle opératoire avant de recommencer le soudage.
- Ne pas obstruer les passages d'air du poste.

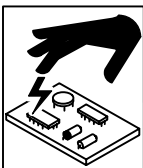

LES CHARGES ÉLECTROSTATIQUES peuvent endommager les circuits imprimés.

- Établir la connexion avec la barrette de terre avant de manipuler des cartes ou des pièces.
- Utiliser des pochettes et des boîtes antistatiques pour stocker, déplacer ou expédier des cartes de circuits imprimés.



DES ORGANES MOBILES peuvent provoquer des blessures.

- Ne pas s'approcher des organes mobiles.
- Ne pas s'approcher des points de coincement tels que des rouleaux de commande.



LES FILS DE SOUDAGE peuvent provoquer des blessures.

- Ne pas appuyer sur la gachette avant d'en avoir reçu l'instruction.
- Ne pas diriger le pistolet vers soi, d'autres personnes ou toute pièce mécanique en engageant le fil de soudage.



DES ORGANES MOBILES peuvent provoquer des blessures.

- Rester à l'écart des organes mobiles comme le ventilateur.
- Maintenir fermés et fixement en place les portes, panneaux, recouvrements et dispositifs de protection.

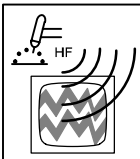

LE RAYONNEMENT HAUTE FRÉQUENCE (H.F.) risque de provoquer des interférences.

- Le rayonnement haute fréquence peut provoquer des interférences avec les équipements de radio-navigation et de communication, les services de sécurité et les ordinateurs.
- Demander seulement à des personnes qualifiées familiarisées avec des équipements électroniques de faire fonctionner l'installation.
- L'utilisateur est tenu de faire corriger rapidement par un électricien qualifié les interférences résultant de l'installation.
- Si le FCC signale des interférences, arrêter immédiatement l'appareil.
- Effectuer régulièrement le contrôle et l'entretien de l'installation.
- Maintenir soigneusement fermés les portes et les panneaux des sources de haute fréquence, maintenir les éclateurs à une distance correcte et utiliser une terre et un blindage pour réduire les interférences éventuelles.

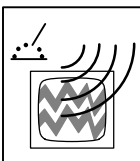

LE SOUDAGE À L'ARC risque de provoquer des interférences.

- L'énergie électromagnétique risque de provoquer des interférences pour l'équipement électronique sensible tel que les ordinateurs et l'équipement commandé par ordinateur tel que les robots.
- Veiller à ce que tout l'équipement de la zone de soudage soit compatible électromagnétiquement.
- Pour réduire la possibilité d'interférence, maintenir les câbles de soudage aussi courts que possible, les grouper, et les poser aussi bas que possible (ex. par terre).
- Veiller à souder à une distance de 100 mètres de tout équipement électronique sensible.
- Veiller à ce que ce poste de soudage soit posé et mis à la terre conformément à ce mode d'emploi.
- En cas d'interférences après avoir pris les mesures précédentes, il incombe à l'utilisateur de prendre des mesures supplémentaires telles que le déplacement du poste, l'utilisation de câbles blindés, l'utilisation de filtres de ligne ou la pose de protecteurs dans la zone de travail.



LES CHAMPS MAGNÉTIQUES peuvent affecter les stimulateurs cardiaques.

- Porteurs de stimulateur cardiaque, restez à distance.
- Les porteurs d'un stimulateur cardiaque doivent d'abord consulter leur médecin avant de s'approcher des opérations de soudage à l'arc, de gougeage ou de soudage par points.

1-4. Principales normes de sécurité

Safety in Welding and Cutting, norme ANSI Z49.1, de l'American Welding Society, 550 N.W. Lejeune Rd, Miami FL 33126

Safety and Health Standards, OSHA 29 CFR 1910, du Superintendent of Documents, U.S. Government Printing Office, Washington, D.C. 20402.

Recommended Safe Practice for the Preparation for Welding and Cutting of Containers That Have Held Hazardous Substances, norme AWS F4.1, de l'American Welding Society, 550 N.W. Lejeune Rd, Miami FL 33126

National Electrical Code, NFPA Standard 70, de la National Fire Protection Association, Batterymarch Park, Quincy, MA 02269.

Safe Handling of Compressed Gases in Cylinders, CGA Pamphlet P-1, de la Compressed Gas Association, 1235 Jefferson Davis Highway, Suite 501, Arlington, VA 22202.

Règles de sécurité en soudage, coupage et procédés connexes, norme CSA W117.2, de l'Association canadienne de normalisation, vente de normes, 178 Rexdale Boulevard, Rexdale (Ontario) Canada M9W 1R3.

Safe Practices For Occupation And Educational Eye And Face Protection, norme ANSI Z87.1, de l'American National Standards Institute, 1430 Broadway, New York, NY 10018.

Cutting and Welding Processes, norme NFPA 51B, de la National Fire Protection Association, Batterymarch Park, Quincy, MA 02269.

1-5. Information sur les champs électromagnétiques

Données sur le soudage électrique et sur les effets, pour l'organisme, des champs magnétiques basse fréquence

Le courant de soudage, pendant son passage dans les câbles de soudage, causera des champs électromagnétiques. Il y a eu et il y a encore un certain souci à propos de tels champs. Cependant, après avoir examiné plus de 500 études qui ont été faites pendant une période de recherche de 17 ans, un comité spécial ruban bleu du National Research Council a conclu: "L'accumulation de preuves, suivant le jugement du comité, n'a pas démontré que l'exposition aux champs magnétiques et champs électriques à haute fréquence représente un risque à la santé humaine". Toutefois, des études sont toujours en cours et les preuves continuent à être examinées. En attendant que les conclusions finales de la recherche soient établies, il vous serait souhaitable de réduire votre exposition aux champs électromagnétiques pendant le soudage ou le coupage.

Afin de réduire les champs électromagnétiques dans l'environnement de travail, respecter les consignes suivantes :

- 1 Garder les câbles ensemble en les torsadant ou en les attachant avec du ruban adhésif.
- 2 Mettre tous les câbles du côté opposé de l'opérateur.
- 3 Ne pas courber pas et ne pas entourer pas les câbles autour de votre corps.
- 4 Garder le poste de soudage et les câbles le plus loin possible de vous.
- 5 Relier la pince de masse le plus près possible de la zone de soudure.

Consignes relatives aux stimulateurs cardiaques :

Les personnes qui portent un stimulateur cardiaque doivent avant tout consulter leur docteur. Si vous êtes déclaré apte par votre docteur, il est alors recommandé de respecter les consignes ci-dessus.

SECTION 2 – INSTALLATION

2-1. Specifications

Rated Output		Max. Open-Circuit Voltage	Amps Input at Rated Output, 50 or 60 Hz, Single-Phase						
			200 (208) V	230 V	400 V	460 V	575 V	KVA	KW
250 A at 28 VDC, 40% Duty Cycle	200 A at 28 VDC, 60% Duty Cycle	38	48 2.3*	42 2*	24 1.2*	21 1*	17 0.8*	9.8 0.46*	7.5 0.13*



Wire Type and Diameter			Wire Feed Speed 25–700 IPM (.65–17.8 m/min)	Dimensions H: 32 in (813 mm) W: 19 in (483 mm) D: 39 in (991 mm)	Net Weight 212 lb (96 kg)
Solid Steel	Stainless Steel	Flux Cored			
.023 – .045 in (0.6 – 1.2 mm)	.023 – .035 in (0.6 – 0.9 mm)	.030 – .045 in (0.8 – 1.2 mm)			

* While idling

Operating Temperature Range – –20C to +40C

Storage Temperature Range – -30C to + 50C

2-2. Welding Power Source Duty Cycle And Overheating

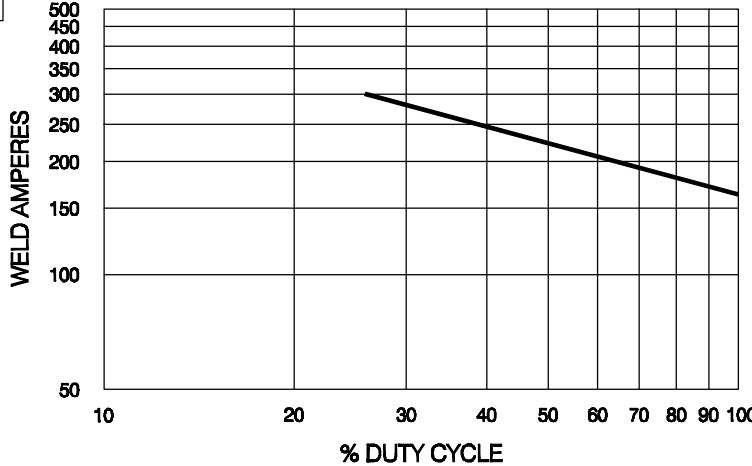

Duty Cycle is percentage of 10 minutes that unit can weld at rated load without overheating.

If unit overheats, thermostat(s) opens, output stops, and cooling fan runs. Wait fifteen minutes for unit to cool. Reduce amperage or voltage, or duty cycle before welding.

▲ Exceeding duty cycle can damage unit and void warranty.

60% Duty Cycle At 200 Amperes

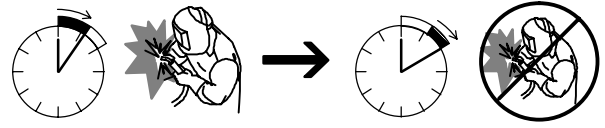

6 Minutes Welding 4 Minutes Resting

40% Duty Cycle At 250 Amperes

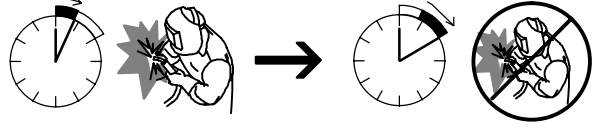

4 Minutes Welding 6 Minutes Resting

Overheating

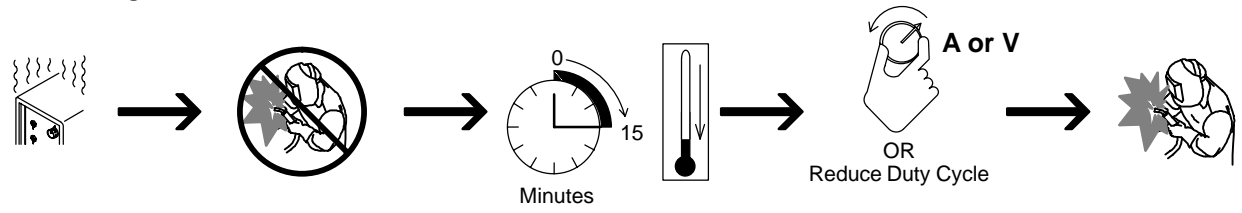

Minutes OR Reduce Duty Cycle



2-3. Welding Gun Duty Cycle And Overheating

CAUTION

WELDING LONGER THAN RATED DUTY CYCLE can damage gun and void warranty.

- Do not weld at rated load longer than shown below.
- Using gasless flux cored wire reduces gun duty cycle.

warn7.1 8/93

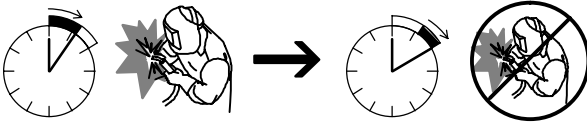
<p>Definition</p>  <p>Duty Cycle is percentage of 10 minutes that gun can weld at rated load without overheating.</p>	<p>.023 To .045 in (0.6 To 1.1 mm) Hard Or Flux Cored Wires</p> <p>100% Duty Cycle At 200 Amperes Using CO₂</p> <p>100% Duty Cycle At 150 Amperes Using Mixed Gases</p>  <p>Continuous Welding</p>	<p>.023 To .045 in (0.6 To 1.1 mm) Hard Or Flux Cored Wires</p> <p>60% Duty Cycle At 300 Amperes Using CO₂</p> <p>60% Duty Cycle At 200 Amperes Using Mixed Gases</p>  <p>6 Minutes Welding 4 Minutes Resting</p> <p>SB1.1 8/93</p>
---------------------------------------------------------------------------------------------------------------------------------------------------------------------------------------------------------------	---------------------------------------------------------------------------------------------------------------------------------------------------------------------------------------------------------------------------------------------------------------------------------------------------------------------	------------------------------------------------------------------------------------------------------------------------------------------------------------------------------------------------------------------------------------------------------------------------------------------------------------------------------------------------------------

2-4. Volt-Ampere Curves

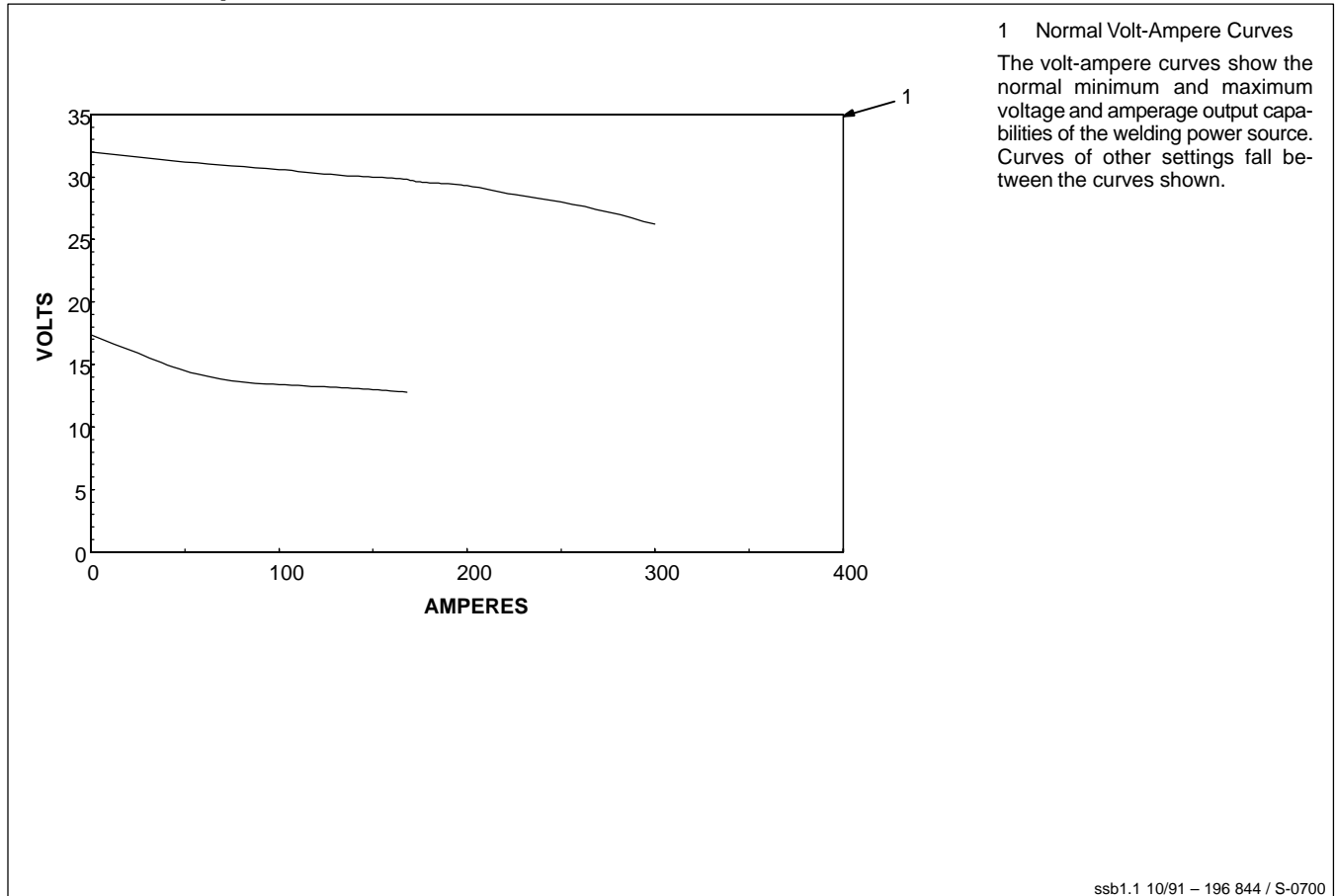

2-5. Installing Work Clamp



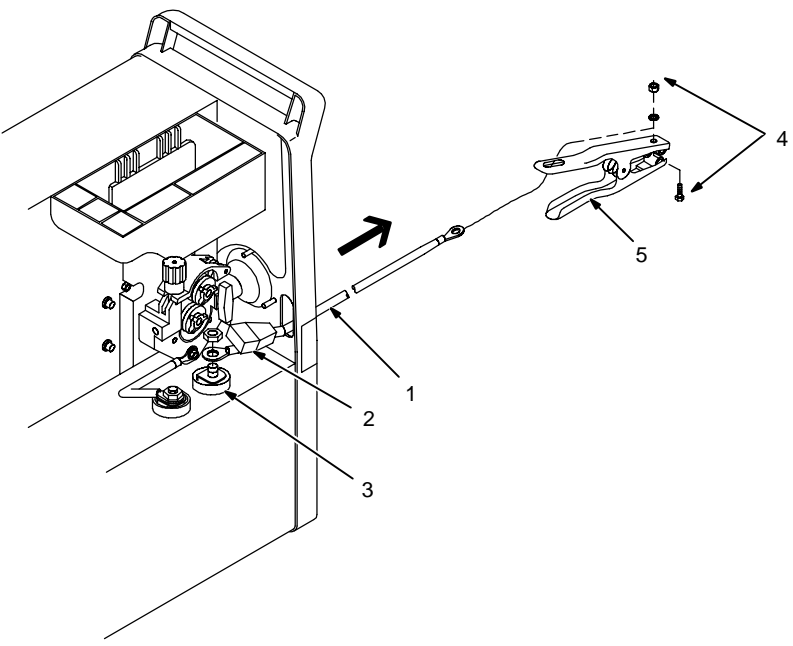

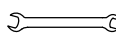

1 Work Cable
2 Boot
Slide boot onto work cable. Route cable out front panel opening from inside.
3 Negative (-) Output Terminal
Connect cable to terminal and cover connection with boot.
4 Hardware
5 Work Clamp
Route cable through clamp handle and secure as shown.
Close door.

Tools Needed:
 1/2, 3/4 in

802 474-A

2-6. Installing Welding Gun



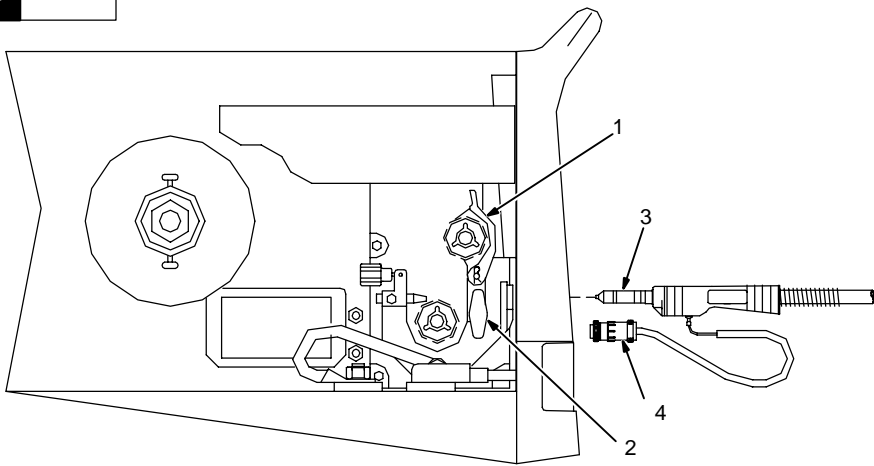

1 Drive Assembly
2 Gun Securing Knob
3 Gun End
Loosen securing knob. Insert gun end through opening until it bottoms against drive assembly (make sure gun end does not touch drive rolls). Tighten knob.
4 Gun Trigger Plug
Insert plug into receptacle, and tighten threaded collar.
Close door.

Ref. 802 064-A

2-7. Connecting A Spoolmatic® 30A Gun

The Spoolmatic 30A welding gun connects directly to the 10-pin receptacle on the front of the welding power source – no adapter required. NOTE: Two welding guns may be connected to the welding power source at the same time, but only one welding gun may be in use at any one time. If the triggers of both welding guns are pulled at the same time, the weld output and wirefeed motor are disabled.

2-8. Setting Gun Polarity For Wire Type



Changing Polarity

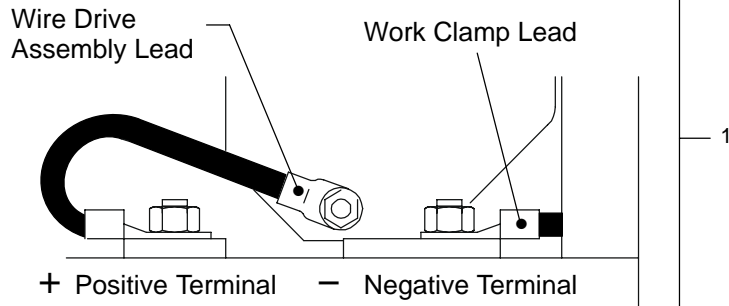

Shown as shipped – **Electrode Positive (DCEP)**: For solid steel, stainless steel, aluminum, or flux core with gas wires (GMAW).

Electrode Negative (DCEN): Reverse lead connections at terminals from that shown above for gasless flux core wires (FCAW). Drive assembly becomes negative.

3/4, 11/16 in

1 Polarity Changeover Label Information

Always read and follow manufacturer's recommended polarity.

Ref. 190 821-A

2-9. Installing Gas Supply

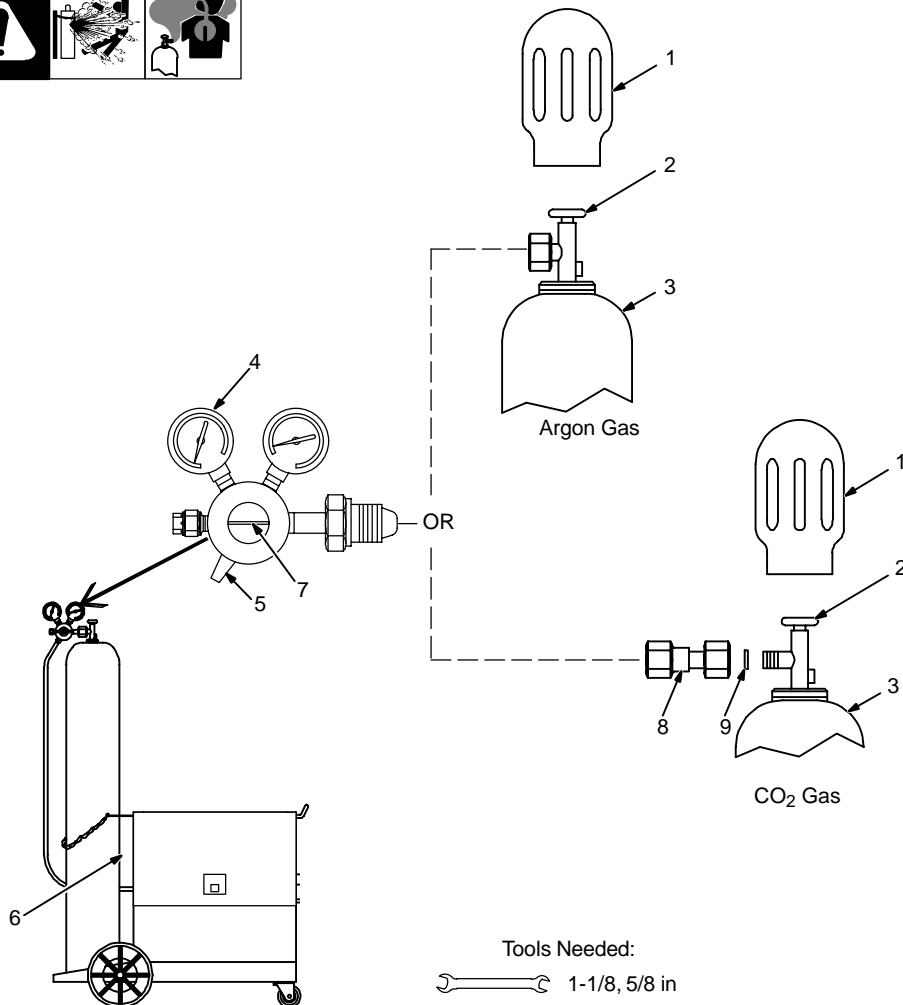

Obtain gas cylinder and chain to running gear, wall, or other stationary support so cylinder cannot fall and break off valve.

- 1 Cap
- 2 Cylinder Valve

Remove cap, stand to side of valve, and open valve slightly. Gas flow blows dust and dirt from valve. Close valve.

- 3 Cylinder
 - 4 Regulator/Flowmeter
- Install so face is vertical.

- 5 Regulator/Flowmeter Gas Hose Connection

- 6 Welding Power Source Gas Hose Connection

Connect customer supplied gas hose between regulator/flowmeter gas hose connection, and fitting on rear of welding power source.

- 7 Flow Adjust



Typical flow rate is 20 cfh (cubic feet per hour). Check wire manufacturer's recommended flow rate.

- 8 CO₂ Adapter (Customer Supplied)
- 9 O-Ring (Customer Supplied)

Install adapter with O-ring between regulator/flowmeter and CO₂ cylinder.

Ref. ST-148 265-B / ST-802 028

2-10. Installing Wire Spool and Adjusting Hub Tension



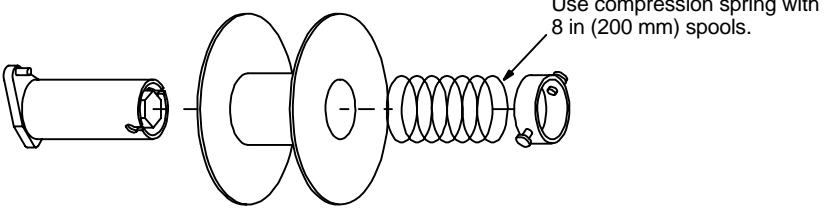



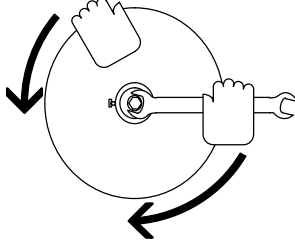

When a slight force is needed to turn spool, tension is set.





Tools Needed:



 15/16 in

ST-072573-B

2-11. Positioning Jumper Links

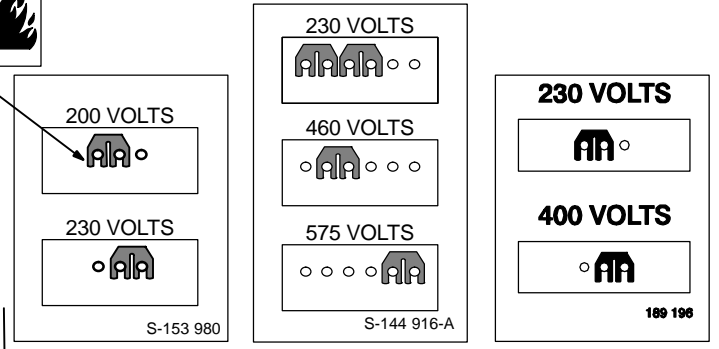





Check input voltage available at site.

- 1 Jumper Links Access Door
Open door.
- 2 Jumper Link Label
Check label – only one is on unit.
- 3 Input Voltage Jumper Links
Move jumper links to match input voltage.

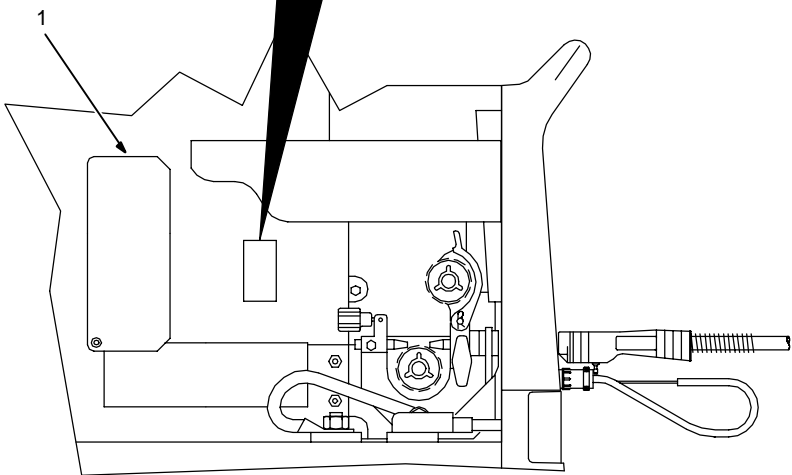
Close and secure access door.

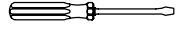
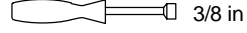

Tools Needed:

 3/8 in

802 476-A

2-12. Electrical Service Guide

Input Voltage	200	230	400	460	575	
Input Amperes At Rated Output	48	42	24	21	17	
Max Recommended Standard Fuse Or Circuit Breaker Rating In Amperes	Circuit Breaker ¹ , Time-Delay ²	60	50	30	25	20
	Normal Operating ³	70	60	35	30	25
Min Input Conductor Size In AWG/Kcmil	8	8	12	12	14	
Max Recommended Input Conductor Length In Feet (Meters)	96 (29)	127 (39)	156 (47)	206 (63)	209 (64)	
Min Grounding Conductor Size In AWG/Kcmil	8	10	12	12	14	

Reference: 1999 National Electrical Code (NEC)

1 Choose a circuit breaker with time-current curves comparable to a Time Delay Fuse.

2 "Time-Delay" fuses are UL class "RK5".

3 "Normal Operating" (general purpose – no intentional delay) fuses are UL class "K5" (up to and including 60 amp), and UL class "H" (65 amp and above).

▲ **Caution:** Failure to follow these fuse and circuit breaker recommendations could create an electric shock or fire hazard.

2-13. Selecting A Location And Connecting Input Power



18 in (457 mm) of space for airflow

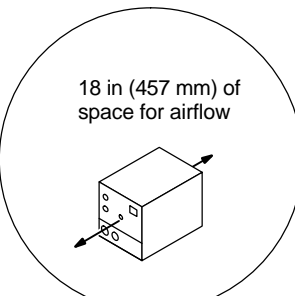

▲ **Do not move or operate unit where it could tip.**

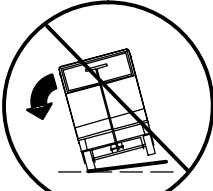

▲ **Always connect grounding conductor first.**

⊕ = GND/PE

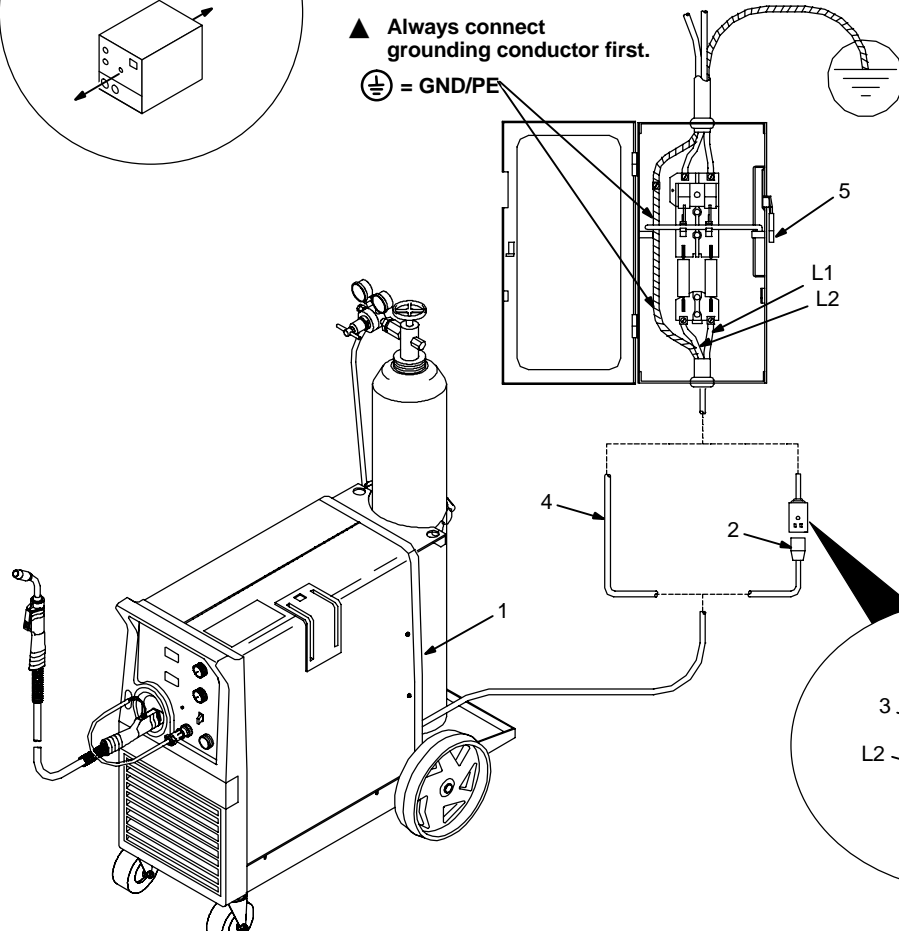

- 1 Rating Label
Supply correct input power.
- 2 Plug (NEMA Type 6-50P)
- 3 Receptacle (NEMA Type 6-50R)
Connect plug to receptacle.
- 4 Input And Grounding Conductors
Connect directly to line disconnect device if hard wiring is required.
- 5 Line Disconnect Device
See Section 2-12.

▲ **Special installation may be required where gasoline or volatile liquids are present – see NEC Article 511 or CEC Section 20.**

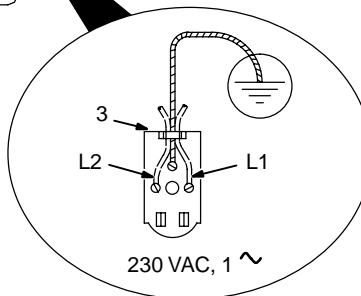

802 477-A

2-14. Threading Welding Wire



- 1 Wire Spool
 - 2 Welding Wire
 - 3 Inlet Wire Guide
 - 4 Pressure Adjustment Knob
 - 5 Drive Roll
 - 6 Outlet Wire Guide
 - 7 Gun Conduit Cable
- Lay gun cable out straight.

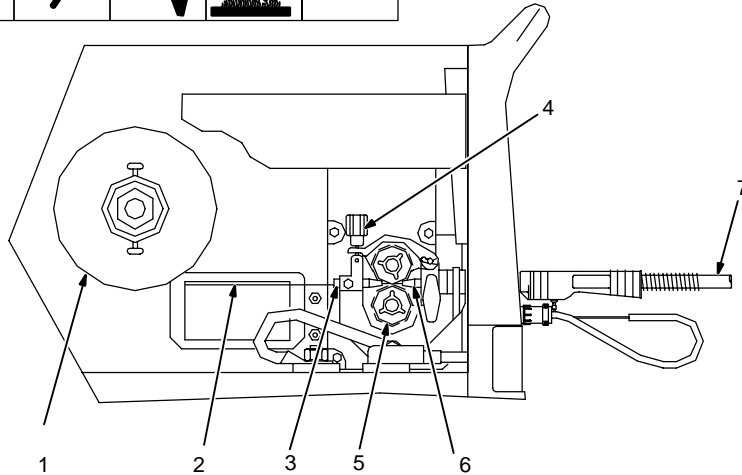

Tools Needed:

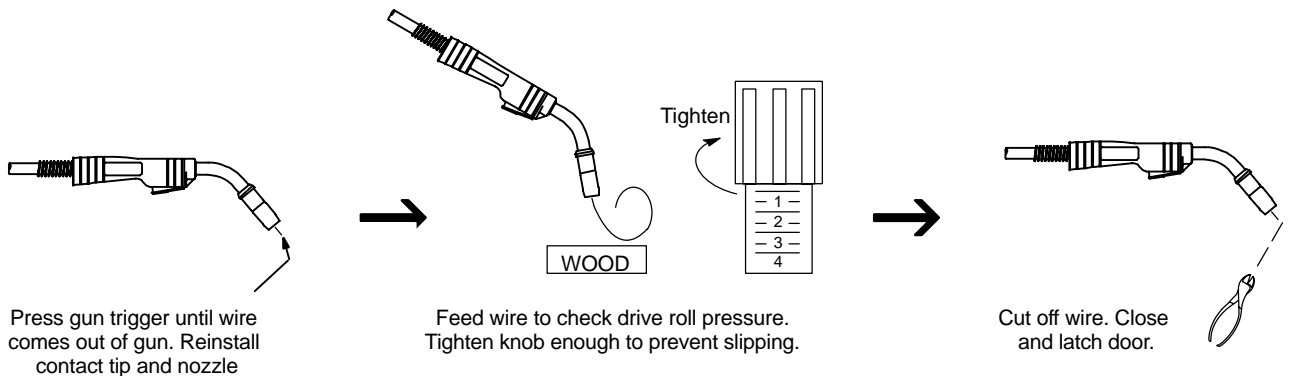
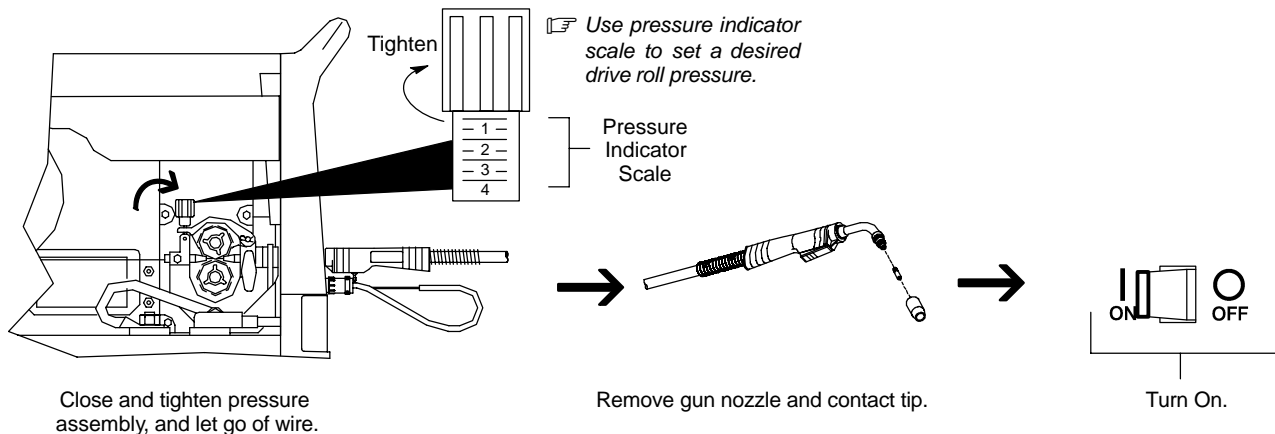
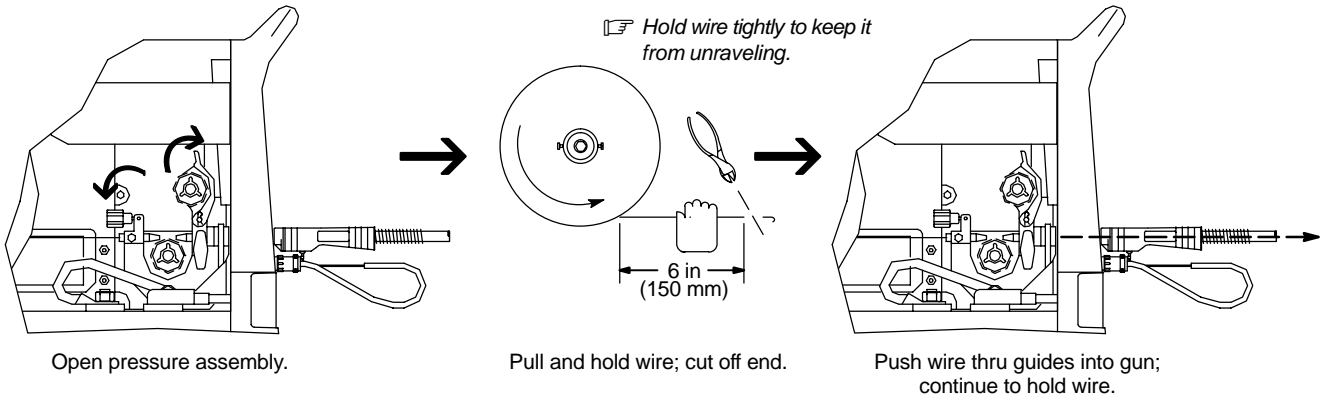
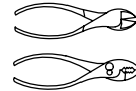

Ref. 802 064-A / S-0627-A

Selecting Wire, Gas and Control Settings

What Material are You Welding?	Suggested Wire Types	Suggested Shielding Gases and Flow Rate	Wire Sizes (Diameter)
Steel	Solid (or hard) ER70S-6	100% CO ₂ , 20 cfh	.023" (0.6 mm) .030" (0.8 mm) .035" (0.9 mm) .045" (1.1 mm)
		75% Ar/25% CO ₂ , 20 cfh (Ar/CO ₂ produces less spatter – better overall appearance)	.023" (0.6 mm) .030" (0.8 mm) .035" (0.9 mm) .045" (1.1 mm)
Steel – for outdoor, windy applications or when weld appearance is not critical.	Flux core E71T-GS	No shielding gas required	.030" (0.8 mm) .035" (0.9 mm) .045" (1.1 mm)
	Flux core E71T-1	100% CO ₂ , 20 cfh 75% Ar/25% CO ₂ , 20 cfh	.035" (0.9 mm) .045" (1.1 mm)
Stainless steel	Stainless steel ER308, ER 308L ER308LSi	Tri-Mix, 20 cfh (90% He/7.5% Ar/ 2.5% CO ₂)	.023" (0.6 mm) .030" (0.8 mm) .035" (0.9 mm) .045" (1.1 mm)
Aluminum with Optional Spoolmatic® 30A spoolgun*	Aluminum 4043 AL	100% Ar, 20 cfh	.030" (0.8 mm) .035" (0.9 mm) .047" (1.2 mm)

*Wire speed for aluminum – use wire feed speed control on Spoolmatic 30A.

Select Voltage and Wire Speed Based on Thickness of Metal Being Welded

To read settings: Number on left of slash is voltage, number on right of slash is wire-speed. "—" Means not recommended.

Example: 19.2/398 =



1/2" (12.7 mm)	3/8" (9.5 mm)	1/4" (6.4 mm)	3/16" (4.8 mm)	1/8" (3.2 mm)	14 ga. (2.0 mm)	16 ga. (1.6 mm)	18 ga. (1.2 mm)	20 ga. (0.9 mm)	22 ga. (0.8 mm)
—	—	—	—	20.1/322	19.3/272	18.7/228	17.3/147	16.0/118	15.3/107
—	—	20.6/300	19.4/252	19.0/206	18.5/180	17.8/152	17.0/100	16.3/90	16.0/80
—	23.5/400	21.5/300	20.0/225	19.5/180	18.5/150	18.0/120	17.5/100	16.5/80	14.5/73
—	21.5/200	21.0/180	20.4/166	20.0/152	19.4/125	19.0/102	18.7/102	—	—
—	—	—	19.1/522	18.1/400	17.4/343	16.5/266	15.3/198	14.0/140	14.0/125
—	21.6/475	19.0/375	17.7/300	17.0/250	16.5/209	16.3/190	15.5/150	14.0/111	14.0/100
—	22.5/465	19.0/310	18.0/275	17.5/213	16.5/160	15.0/125	14.4/104	14.0/95	14.0/90
28.3/400	25.6/354	19.7/254	18.6/220	17.7/180	16.5/148	16.0/125	15.5/93	—	—
—	—	19.0/380	18.0/300	17.0/230	15.0/138	14.0/110	—	—	—
—	21.8/390	19.8/307	18.5/299	17.8/242	15.3/95	15.0/87	—	—	—
—	22.0/224	19.7/188	18.8/171	18.0/131	17.4/103	—	—	—	—
—	28.3/560	26.0/482	25.1/370	24.0/296	19.6/183	—	—	—	—
27.7/395	26.2/372	25.1/235	23.2/275	20.8/201	—	—	—	—	—
—	—	—	—	21.5/460	21.0/330	19.0/200	18.1/145	—	—
—	—	19.9/398	19.2/311	18.5/255	18.3/231	17.5/182	17.0/142	—	—
—	20.5/363	19.6/297	19.1/270	18.5/235	17.9/198	17.5/172	—	—	—
—	20.1/291	19.5/250	19.1/225	18.6/175	—	—	—	—	—
—	—	22.0/620	20.8/490	19.0/450	18.3/400	—	—	—	—
—	24.5/530	22.5/460	21.0/420	20.0/360	18.1/350	—	—	—	—
28.3/650	26.0/535	23.5/450	21.6/400	20.0/330	—	—	—	—	—

2-16. Using Gun/Cable Holder

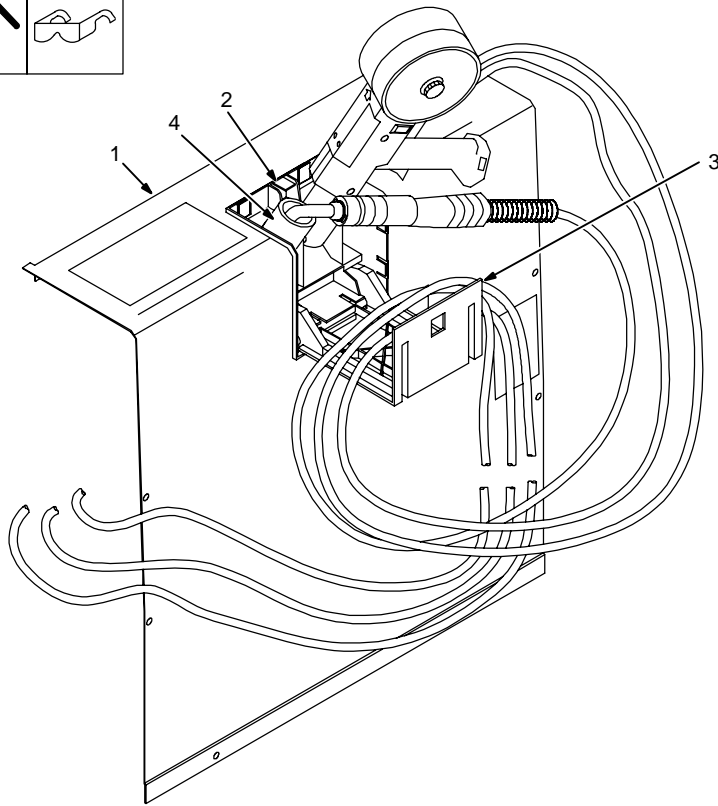

1 Side Panel

2 Latch

3 Cable Holder

Press latch down to release and open door.

4 Holster (2)

Wrap cable around cable holder, and place gun nozzle into holster.

Ref. 802 726-A

SECTION 3 – OPERATION

3-1. Controls



- 1 Voltage Control
Turn control clockwise to increase voltage.
- 2 Wire Speed Control
Turn control clockwise to increase wire feed speed.
- 3 Power Switch
- 4 Voltmeter
- 5 Wire Feed Speed Meter

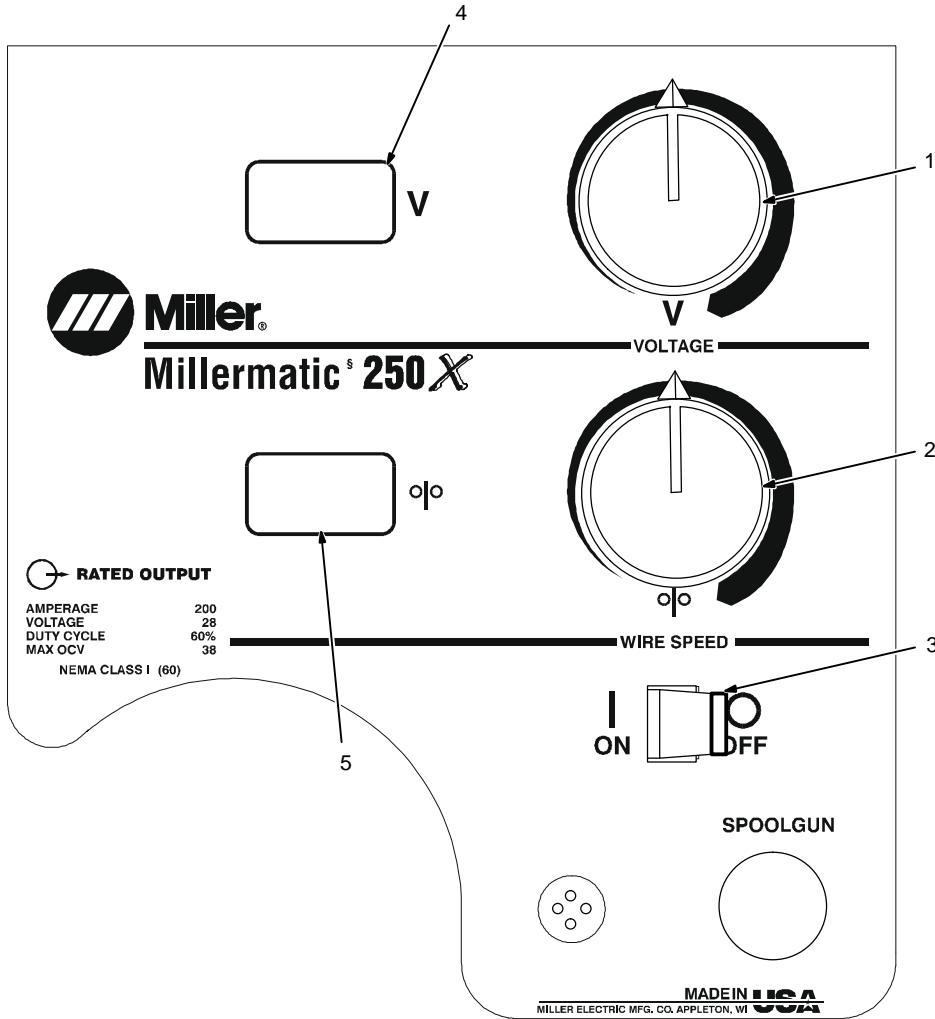

196 672

3-2. Voltmeter And Wire Feed Speed Meter Operation

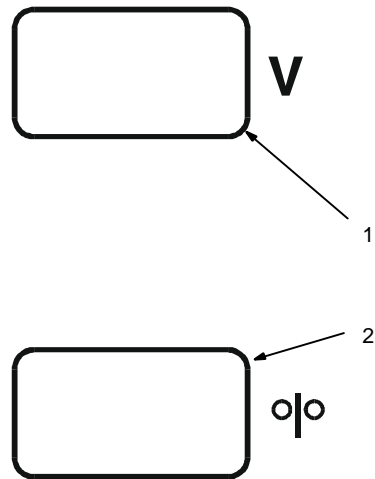

- 1 Voltmeter
- 2 Wire Feed Speed Meter

Power Up Status

Both meters display zeros at unit power up. After one second, preset values appear on both meters. The MIG gun settings (not spool gun) are always the default at initial power up of the unit.

Welding Status

When either a MIG gun or spool gun trigger is pressed and a welding arc is established, the voltmeter displays actual weld voltage. When the gun trigger is released and welding arc extinguished, the voltmeter displays the last actual voltage for 5 seconds and then returns to preset voltage. If welding resumes before unit displays preset voltage, actual welding voltage will appear on the voltmeter.

The wire feed speed meter always displays preset wire feed speed (IPM).

Gun Selection

The wire feed speed meter will display preset wire feed speed (IPM) for the appropriate gun selection either MIG or spool gun. To preset desired wire feed speed, connect desired gun, press gun trigger for one second, and release trigger. The meter preset will be retained by the meter board until a different gun is connected and preset is performed or the unit is turned off and back on. The MIG gun settings (not spool gun) are always the default at initial power up of the unit.

Error Message

If the rectifier thermostat opens, the voltmeter will display (H --) and the wire feed speed meter will display (- - -). During this overheated condition, the unit is inoperative and the meters retain their display until the rectifier returns to normal operating temperature.

SECTION 4 – MAINTENANCE & TROUBLESHOOTING

4-1. Routine Maintenance

				▲ Disconnect power before maintaining.	☞ <i>Maintain more often during severe conditions.</i>
	3 Months				
Replace unreadable labels			Repair or replace cracked weld cable		
Clean and tighten weld terminals					
	6 Months				
Blow out or vacuum inside.		OR		Remove drive roll and carrier. Apply light coat of oil or grease to drive motor shaft.	

4-2. Circuit Breaker CB1

					<p>1 Circuit Breaker CB1 If CB1 opens, wire feeding stops.</p> <p>2 Circuit Breaker CB2 Overcurrent at pin D of receptacle RC7 will cause CB2 to open.</p> <p>3 Welding Gun Check gun liner for blockage or kinks.</p> <p>4 Wire Drive Assembly Check for jammed wire, binding drive gear or misaligned drive rolls. Allow cooling period and reset breaker. Close door.</p>
					802 475-A / Ref. 800 797-C

4-3. Unit Overload

Thermostat TP1 in rectifier Z1 protects the unit from damage due to overheating. If TP1 opens, wait several minutes before trying to weld.

4-4. Replacing Gun Contact Tip

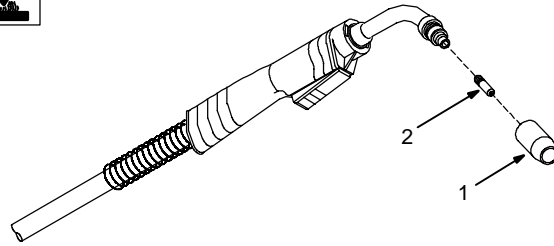

▲ Turn Off power.

- 1 Nozzle
- 2 Contact Tip

Cut off welding wire at contact tip. Remove nozzle.

Remove contact tip and install new contact tip. Reinstall nozzle.

Tools Needed:

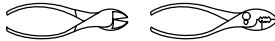

Ref. 800 797-C

4-5. Changing Drive Roll and Wire Inlet Guide

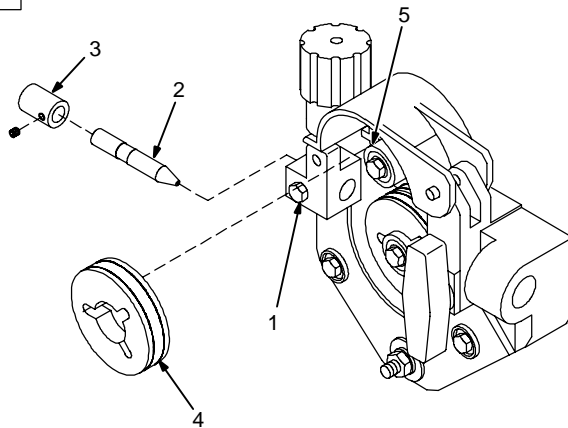

- 1 Securing Screw
- 2 Inlet Wire Guide

Loosen screw. Slide tip as close to drive rolls as possible without touching. Tighten screw.

3 Anti-Wear Guide
Install guide as shown.

4 Drive Roll

Install correct drive roll for wire size and type.

5 Drive Roll Securing Nut

Turn nut one click to secure drive roll.

Tools Needed:

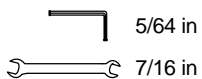

ST-150 227-D

4-6. Aligning Drive Rolls and Wire Guide

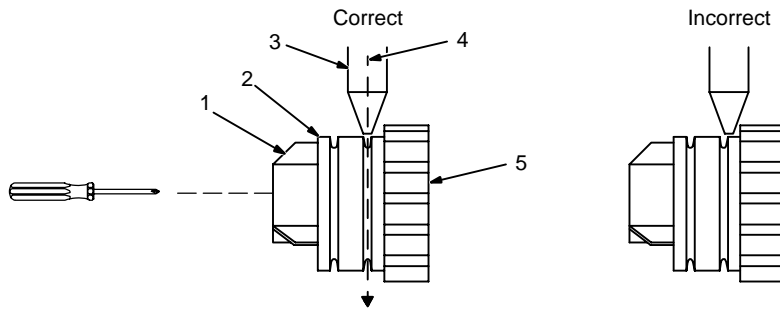
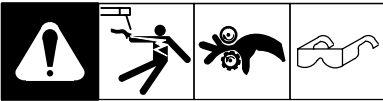

▲ Turn Off power.

View is from top of drive rolls looking down with pressure assembly open.

- 1 Drive Roll Securing Nut
- 2 Drive Roll
- 3 Wire Guide
- 4 Welding Wire
- 5 Drive Gear

Insert screwdriver, and turn screw in or out until drive roll groove lines up with wire guide.

Close pressure roll assembly.

Tools Needed:



Ref. ST-800 412-A

4-7. Cleaning Or Replacing Gun Liner

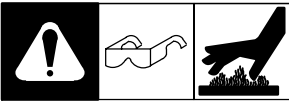

▲ Disconnect gun from unit first.

Tools Needed:

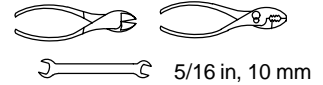

5/16 in, 10 mm

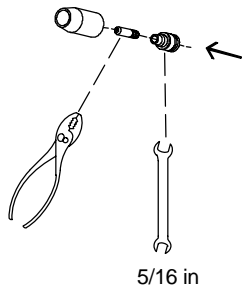

5/16 in

Head Tube

Remove nozzle, contact tip, and adapter.

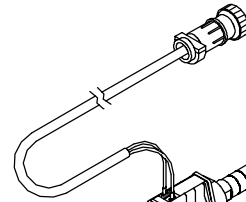

Lay gun cable out straight before installing new liner.

10 mm



Remove liner.

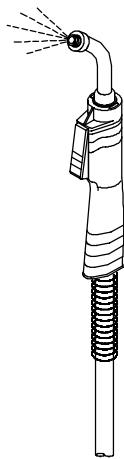

Blow out gun casing.

To Reassemble Gun:

Install and tighten new liner.

Cut liner off 3/4 in (20 mm) (3/8 in [9.5 mm] for aluminum) from head tube.

Install adapter, contact tip, and nozzle.

Ref. ST-800 797-C

4-8. Replacing Switch And/Or Head Tube

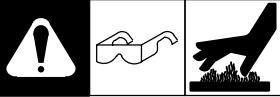

▲ Disconnect gun first.

1 Remove handle locking nut.

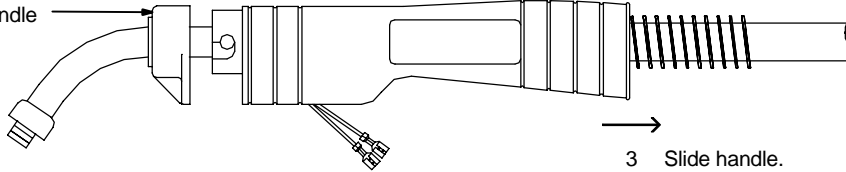

3 Slide handle.

2 Remove switch housing. Note: If installing new switch, push switch lead connectors onto terminal of new switch (polarity is not important). Install switch back into handle, and secure with handle locking nut. If replacing head tube, continue to end of figure.

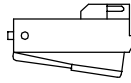

4 Secure head tube in vice.

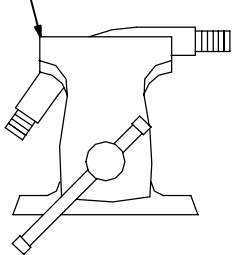

5 Loosen jam nut. Remove from vice and turn head tube out by hand.

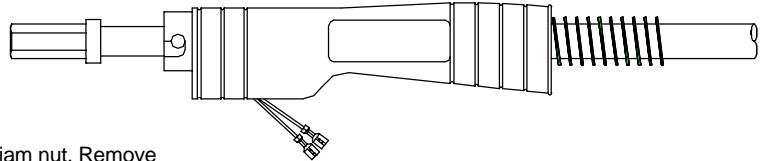
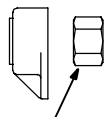

6 Install existing shock washer onto new head tube. Hand-tighten head tube into connector cable.

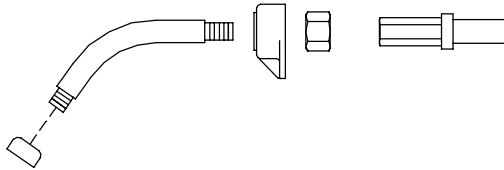

7 Place head tube in vice and tighten until nuts are tight.

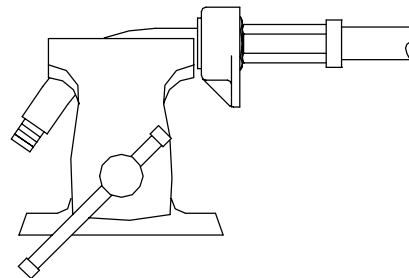

8 Remove from vice. Reposition handle and install switch housing. Secure with handle locking nut.

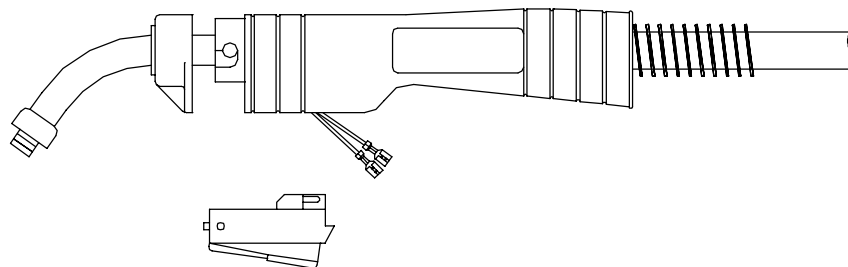

Tools Needed:

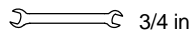

Ref. ST-800 795-C

4-9. Troubleshooting



Trouble	Remedy
No weld output; wire does not feed.	Be sure line disconnect switch is On (see Section 2-13).
	Replace building line fuse or reset circuit breaker if open (see Section 2-13).
	Reset circuit breaker CB1 (see Section 4-2).
	Secure gun trigger connections (see Section 2-6).
	Have Factory Authorized Service Agent check Power switch.
	Have Factory Authorized Service Agent check all board connections and main control board.
	H -- message appears on voltmeter display to indicate thermostat TP1 is open and unit is in an overheated condition (see Section 3-2).
No weld output; wire feeds.	Thermostat TP1 open (overheating). Allow fan to run; the thermostat will close when the unit has cooled (see Section 2-2).
	Connect work clamp to get good metal to metal contact.
	Replace contact tip (see Section 4-4).
	Have Factory Authorized Service Agent check main control board and main rectifier.
Low weld output.	Connect unit to proper input voltage or check for low line voltage (see Section 2-13).
	Check input voltage jumper links and correct position if necessary (see Section 2-11).
	Have Factory Authorized Service Agent check main control board.
Fan motor does not run.	Have Factory Authorized Service Agent check fan-on-demand circuit.
Low, high, or erratic wire speed.	Readjust front panel settings (see Section 3-1).
	Change to correct size drive rolls (see Section 4-5).
	Readjust drive roll pressure (see Section 2-14).
	Replace inlet guide, contact tip, and/or liner if necessary (see Sections 4-4, and 4-7).
	Check position of input jumper links (see Section 2-11).
	Have Factory Authorized Service Agent check main control board.
No wire feed.	Reset circuit breaker CB1 (see Section 4-2).
	Turn Wire Speed control to higher setting (see Section 3-1).
	Clear obstruction in gun contact tip or liner (see Sections 4-4, and 4-7).
	Readjust drive roll pressure (see Section 2-14).
	Change to correct size drive rolls (see Section 4-5).
	Rethread welding wire (see Section 2-14).
	Check gun trigger and leads. Repair or replace gun if necessary.
	Have Factory Authorized Service Agent check main control board.
	H -- message appears on voltmeter display to indicate thermostat TP1 is open and unit is in an overheated condition (see Section 3-2).

SECTION 5 – ELECTRICAL DIAGRAM

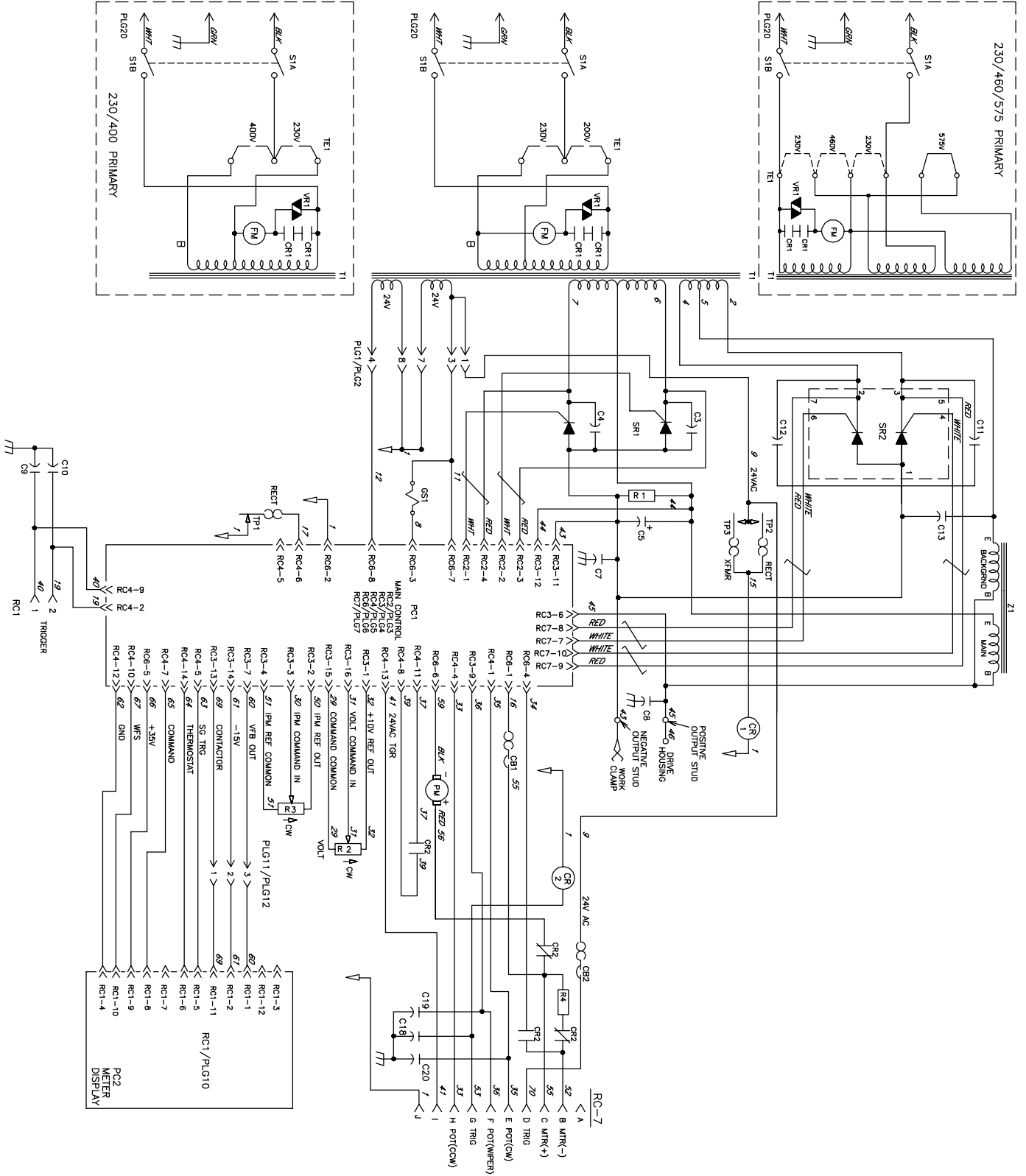



Figure 5-1. Circuit Diagram

SECTION 6 – PARTS LIST

 Hardware is common and not available unless listed.

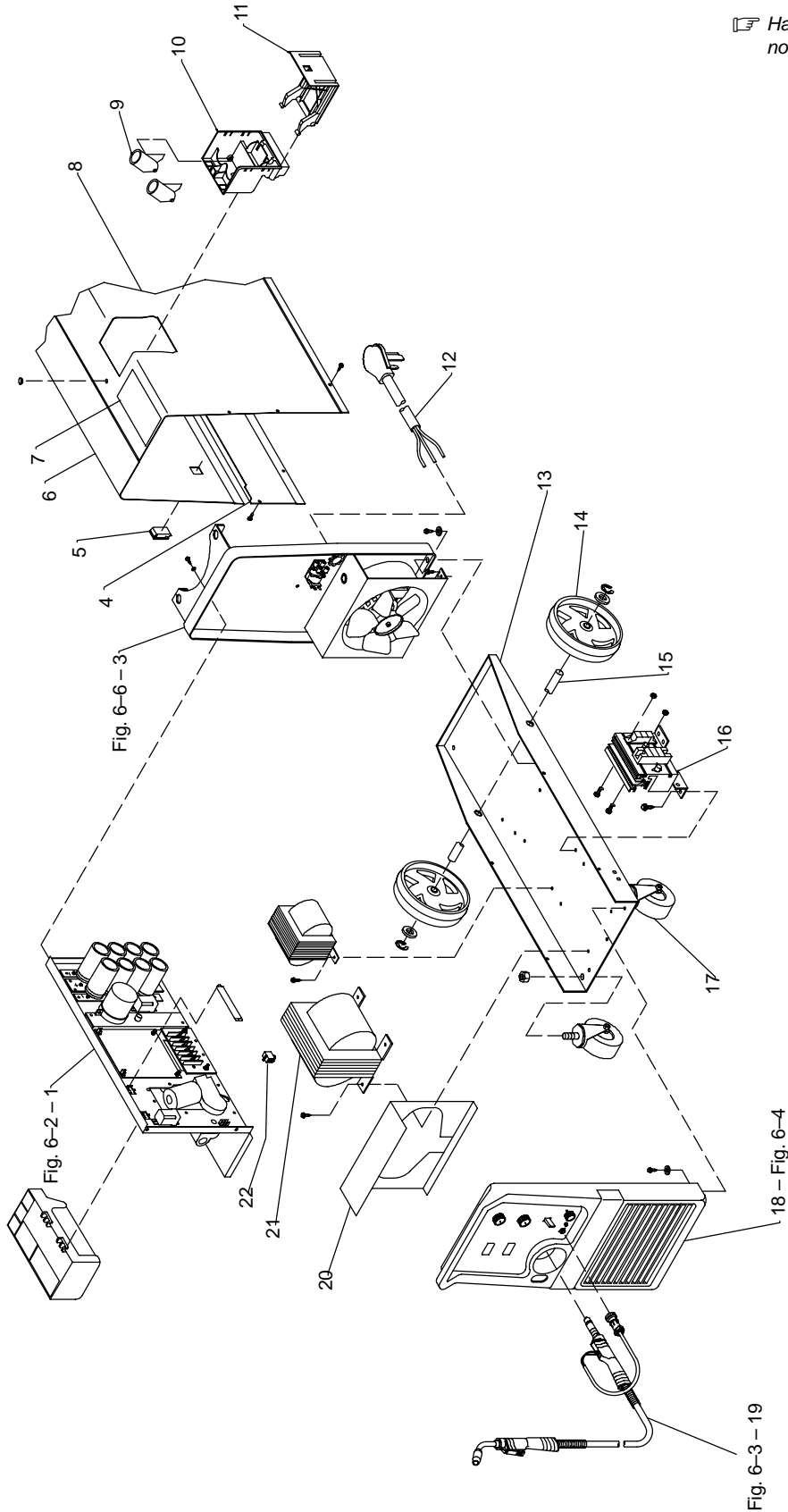



Figure 6-1. Main Assembly

Item No.	Dia. Mkgs.	Part No.	Description	Quantity
Figure 6-1. Main Assembly				
...	1	...	Fig 6-2 ... BAFFLE, center w/components	1
...	2	Z1 199 159	STABILIZER, dual	1
...	3	...	Fig 6-6 ... PANEL, rear w/components	1
...	4	203 481	PANEL, side LH	1
...	5	151 187	LATCH, slide flush mtg hole 1.000 wide x 1.500 lg	2
...	6	203 480	PANEL, side	1
...		196 843	LABEL, parameters/consumables/polarity/warning	1
...	7	134 464	LABEL, warning general precautionary	1
...	8	+203 482	WRAPPER	1
...		193 328	LABEL, warning electric shock and incorrect input	1
...		201 019	LABEL, warning electric shock excess weight	1
...		200 923	GUN/CABLE HOLDER, (consisting of)	1
...	9	200 921	HOLSTER, gun/cable holder	2
...	10	200 922	HOUSING, gun/cable holder	1
...	11	200 920	DOOR, gun/cable holder	1
...	12	188 911	CABLE, pwr 250v 6-50p 8-10ga 3/c 12ft for 200/230	1
...	12	187 255	CABLE, pwr 250v t tng 8-10ga 3/c 12ft for 230/460/575 or 230/400	1
...	13	146 161	BASE	1
...	14	186 758	WHEEL	2
...	15	052 692	AXLE, running gear (consisting of)	1
...		121 614	RING, retaining ext .750 shaft x .085grv depth	2
...	16	197 703	RECTIFIER, SCR main (consisting of)	1
...		SR1 197 698	THYRISTOR, SCR module 300A 400V common anode (large)	1
...		SR2 196 754	THYRISTOR, SCR module 95A 400V dual (small)	1
...		C1,2,3,4 031 689	CAPACITOR, rectifier	4
...		TP1 154 243	THERMOSTAT, NC	1
...		TP2 154 244	THERMOSTAT, NO	1
...		143 852	FOOT, mtg rectifier	1
...		198 232	FOOT, mtg rectifier	1
...		PLG3 115 094	HOUSING PLUG & SKTS (4 position)	1
...		PLG7 115 091	HOUSING PLUG & SKTS (10 position)	1
...	17	008 999	CASTER, plstc swvl 4 in dia	2
...	18	...	Fig 6-4 ... PANEL, front w/components	1
...	19	169 596	GUN, 12ft .030-.035 wire (Fig 6-3)	1
...	20	150 387	BAFFLE, air	1
...	21	T1 196 795	TRANSFORMER, pwr main (200/230)	1
...	21	T1 196 864	TRANSFORMER, pwr main (230/460/575)	1
...	21	T1 196 988	TRANSFORMER, pwr main (230/400)	1
...		TP3 121 497	THERMOSTAT, NO	1
...	22	PLG2 008 072	HOUSING RECEPTACLE & SOCKETS (harness)	1
...		PLG1 008 073	HOUSING RECEPTACLE & SOCKETS (xfmr)	1
...		203 388	REGULATOR/FLOWMETER, 10-50 CFH Argon/CO ₂	1
...		144 108	HOSE, gas	1
...		130 750	CLAMP, ground 350A	1
...		600 318	CABLE, weld cop strd No. 3 (order by ft)	10ft
...		193 723	LABEL, Miller Millermatic	2

+When ordering a component originally displaying a precautionary label, the label should also be ordered.

To maintain the factory original performance of your equipment, use only Manufacturer's Suggested Replacement Parts. Model and serial number required when ordering parts from your local distributor.

 Hardware is common and not available unless listed.

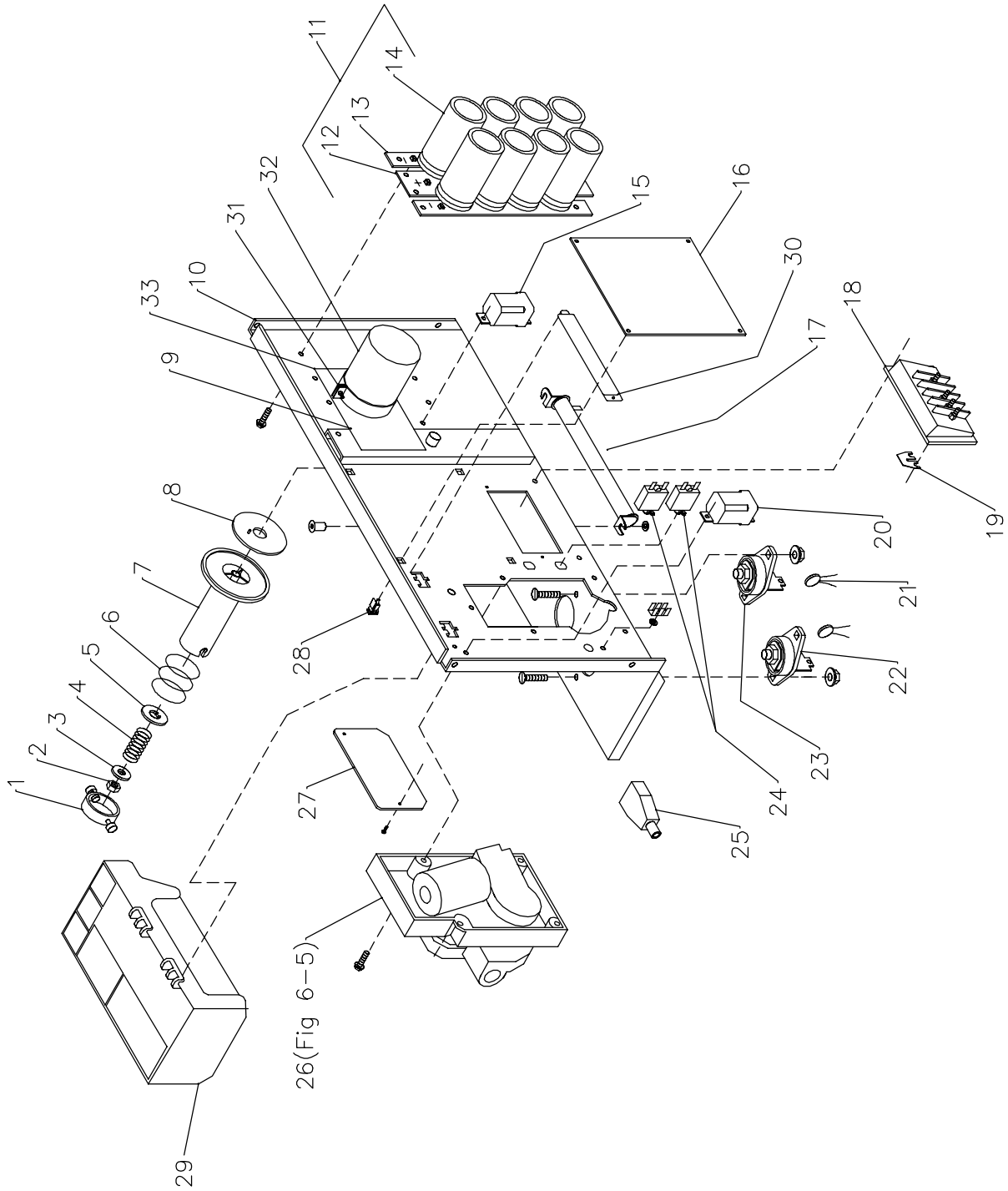

Figure 6-2. Baffle, Center w/Components

802 060-C

Item No.	Dia. Mkgs.	Part No.	Description	Quantity
Figure 6-2. Baffle, Center w/Components (Fig 6-1 Item 1)				
...	1	058 427	RING, retaining spool	1
...	2	085 980	NUT, stl hex full .625-11	1
...	3	605 941	WASHER, flat stl .640 ID x 1.000 OD x 14ga thk	1
...	4	186 437	SPRING, cprsn .845 OD x .110 wire x 1.500	1
...	5	057 971	WASHER, flat stl keyed 1.500dia x .125thk	1
...	6	057 745	SPRING, cprsn 2.430 OD x .090 wire x 2.500	1
...	7	186 435	HUB, spool	1
...	8	186 436	WASHER, brake	1
...	9	177 307	REEL, support	1
...	10	196 797	BAFFLE, center	1
...	11	186 998	CAPACITOR ASSEMBLY KIT, (consisting of)	1
...	12	082 902	STRIP, mtg center capacitor	1
...	13	185 643	STRIP, mtg capacitors	2
...		083 147	GROMMET, scr No. 8/10 panel hole .312sq .500 high	6
...	14	C5	184 584 CAPACITOR, elctlt 15000uf 45VDC	8
...		187 752	INSULATOR, capacitor	1
...	15	CR1	006 393 RELAY, 24VAC DPDT 10A/120VAC	1
...		144 425	VARISTOR, 430V	1
...	16	PC1	196 456 CIRCUIT CARD, control	1
...		PLG3	115 094 HOUSING PLUG & SOCKETS	1
...		PLG4	131 052 HOUSING RECEPTACLE & SOCKETS	1
...		PLG5	131 056 HOUSING RECEPTACLE & SOCKETS	1
...		PLG6	115 092 HOUSING PLUG & SOCKETS	1
...		PLG7	130 203 HOUSING PLUG & SOCKETS	1
...	17	R5	119 998 RESISTOR, WW fxd 300W 5 ohm	1
...	18	TE1	188 910 TERMINAL ASSEMBLY, pri 1ph double voltage (200/230 or 230/400)	1
...	18	TE1	192 907 TERMINAL ASSEMBLY, pri 1ph triple voltage (230/460/575)	1
...	19		038 618 LINK, jumper term bd pri	as req.
...	20	CR2	000 174 RELAY, 24VAC 3PDT 10A/120VAC	1
...		189 364	RESISTOR, w/terminals	1
...	21	C3,5	128 750 CAPACITOR	2
...	22	POS	097 421 TERMINAL, pwr output red	1
...	23	NEG	097 416 TERMINAL, pwr output black	1
...	24	CB1,CB2	180 912 CIRCUIT BREAKER, man reset 1P 5A 250VAC	2
...	25		196 318 COVER, cable	1
...	26		Fig 6-5 WIRE DRIVE & GEARS	1
...	27		188 917 DOOR, access changeover	1
...	28		134 201 STAND-OFF SUPPORT, PC card	4
...	29		197 555 TOOL TRAY	1
...	30		196 894 COVER	1
...	31		108 105 CLAMP, capacitor	1
...	32	C13	186 311 CAPACITOR, electlt 91000uf 35VDC	1
...	33		196 800 BRACKET, mtg capacitor	1

+When ordering a component originally displaying a precautionary label, the label should also be ordered.

To maintain the factory original performance of your equipment, use only Manufacturer's Suggested Replacement Parts. Model and serial number required when ordering parts from your local distributor.

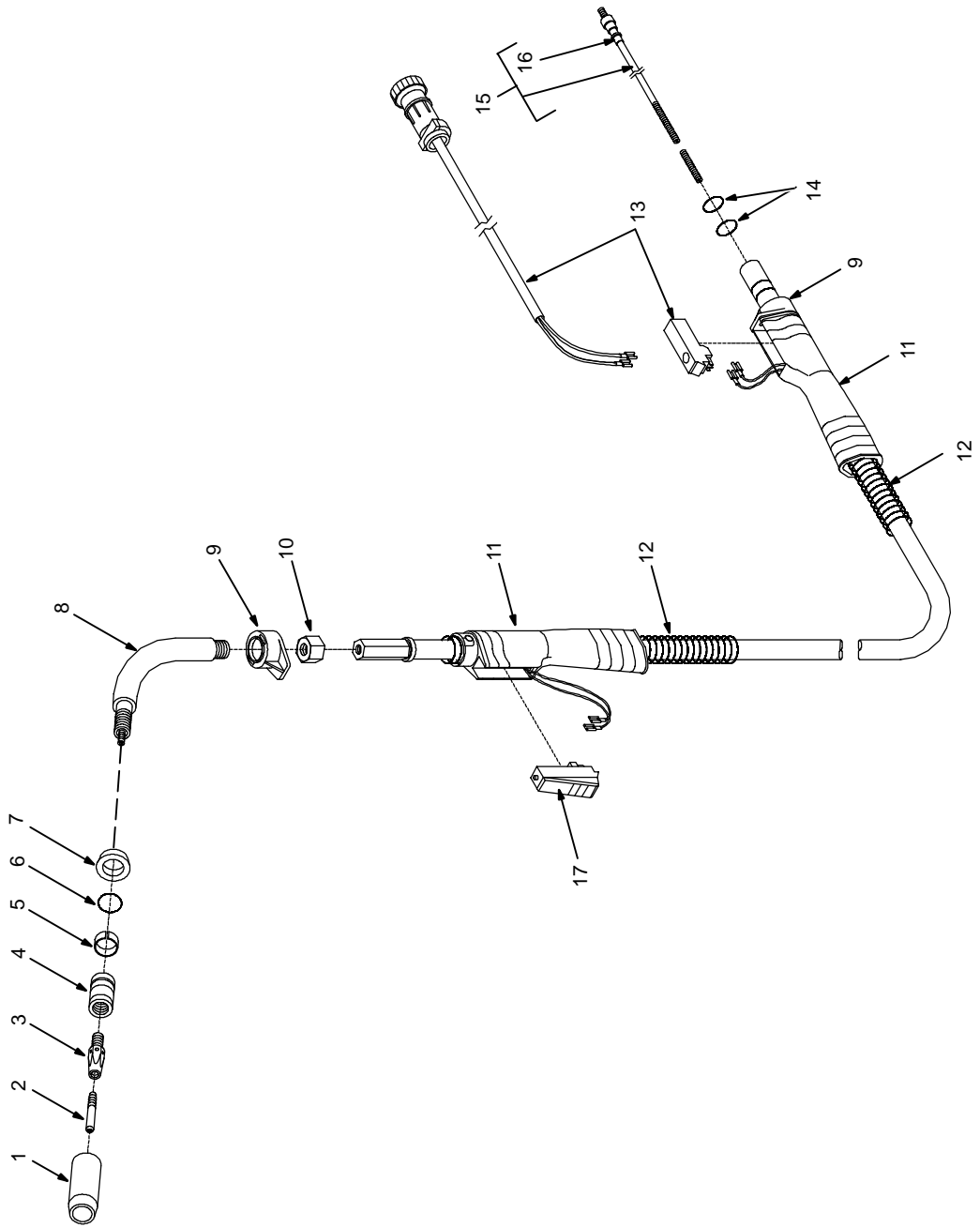

Figure 6-3. M-25 Gun

Ref. 800 792-B

Item No.	Part No.	Description	Quantity
----------	----------	-------------	----------

Figure 6-3. M-25 Gun (Fig 6-1 Item 16)

...	1	200 258	.. NOZZLE, slip type .500 orf flush	1
...	1	◆169 724	.. NOZZLE, slip type .500 orf .125 recess	
...	1	◆169 725	.. NOZZLE, slip type .625 orf .125 recess	
...	1	◆169 726	.. NOZZLE, slip type .625 orf flush	
...	1	◆169 727	.. NOZZLE, slip type .625 orf .125 stickout	
...	2	◆087 299	.. TIP, contact scr .023 wire x 1.125	
...	2	◆000 067	.. TIP, contact scr .030 wire x 1.125	
...	2	◆000 068	.. TIP, contact scr .035 wire x 1.125	
...	2	◆000 069	.. TIP, contact scr .045 wire x 1.125	
...	3	169 728	.. ADAPTER, contact tip	1
...	4	169 729	.. ADAPTER, nozzle	1
...	5	170 467	.. RING, retaining	1
...	6	170 468	.. O-RING	1
...	7	169 730	.. WASHER, shock	1
...	8	169 731	.. TUBE, head	1
...	9	169 738	.. NUT, locking handle	2
...	10	194 523	.. NUT, jam	1
...	11	169 737	.. HANDLE	2
...	12	169 741	.. STRAIN RELIEF, cable	2
...	13	180 433	.. CORD, trigger assembly	1
...	14	079 974	.. O-RING, .500 ID x .103CS rbr	2
...	15	◆194 010	.. LINER, monocoil .023/.025 wire x 15ft (consisting of)	1
...	15	◆194 011	.. LINER, monocoil .030/.035 wire x 15ft (consisting of)	1
...	15	◆194 012	.. LINER, monocoil .035/.045 wire x 15ft (consisting of)	1
...	16	079 975	.. O-RING, .187 ID x .103CS rbr	1
...	17	196 255	.. SWITCH, trigger	1

◆OPTIONAL

To maintain the factory original performance of your equipment, use only Manufacturer's Suggested Replacement Parts. Model and serial number required when ordering parts from your local distributor.

Item No.	Dia. Mkgs.	Part No.	Description	Quantity
----------	------------	----------	-------------	----------

Figure 6-4. Panel, Front w/Components (Fig 6-1 Item 15)

...	1	...	+196 798	..	PANEL, front control	...	1
...		...	196 672	..	LABEL, nameplate	...	1
...	2	...	196 399	..	CIRCUIT CARD ASSY, display	...	1
...		PLG10	130 203	..	PLUG w/SOCKETS	...	1
...		PLG11	131 203	..	PLUG w/PINS	...	1
...		PLG12	131 204	..	PLUG w/SOCKETS	...	1
...	3	...	134 201	..	STANDOFF	...	4
...	4	...	196 801	..	BRACKET, mtg display board	...	1
...	5	C9,10,18, 19,20	136 735	..	CAPACITOR, cer disc .1uf 500VDC	...	5
...	6	R2,3	198 087	..	POTENTIOMETER	...	2
...			131 052	..	HOUSING RECEPTACLE & SOCKETS	...	1
...	7	...	186 473	..	PANEL, front	...	1
...	8	S1	128 755	..	SWITCH, tgl	...	1
...	9	RC1	048 282	..	RECEPTACLE w/SOCKETS	...	1
...	10	RC7	190 363	..	RECEPTACLE w/SOCKETS	...	1
...	11	...	186 470	..	PANEL, logo	...	1
...	12	...	038 502	..	Cable Tie,	...	1
...	13	...	186 472	..	PANEL, louver (Order Item 9, Cable Tie when ordering louver panel)	...	1
...	14	...	193 632	..	NUT, 375-16 .56 hex .34H stl	...	2
...	15	...	097 924	..	KNOB, pointer 1.625dia x .250 ID	...	2

 Hardware is common and not available unless listed.

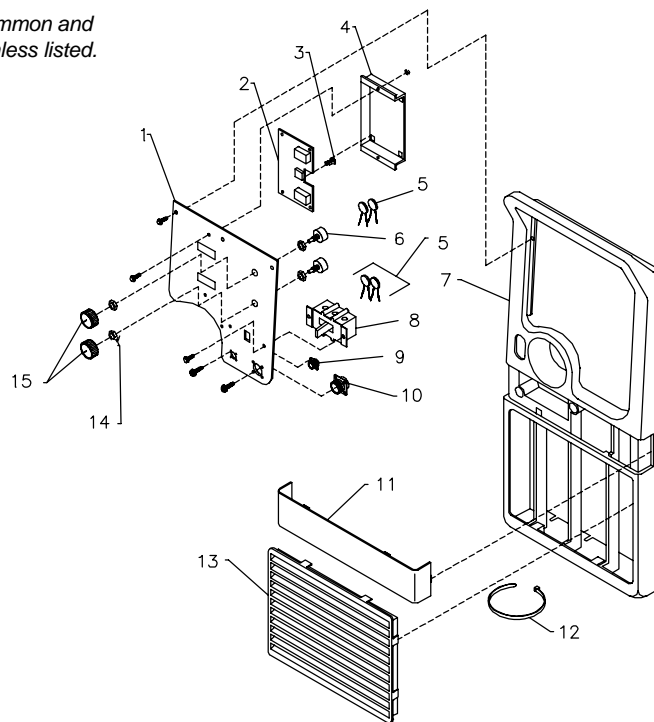

802 087-C

Figure 6-4. Panel, Front w/Components

To maintain the factory original performance of your equipment, use only Manufacturer's Suggested Replacement Parts. Model and serial number required when ordering parts from your local distributor.

Item No.	Dia. Mkgs.	Part No.	Description	Quantity
----------	------------	----------	-------------	----------

Figure 6-5. Wire Drive And Gears (Fig 6-2 Item 26)

...	1	602 009	... SCREW, .250-20 x 1.25 soc hd gr 8	1
...	2	172 075	... CARRIER, drive roll w/components	1
...	3	166 072	... SPACER, gear	1
...	4	010 224	... PIN, spring CS .187 x 1.000	1
...	5	182 788	... HOUSING, adapter gun/feeder	1
...	6	085 242	... FASTENER, pinned	1
...	7	196 896	... CUP, spring	1
...	8	196 897	... SPRING, cprsn .695 OD x .095 wire	1
...	9	196 895	... KNOB, tension adj	1
...	10	166 071	... LEVER, mtg pressure gear	1
...	11	079 634	... PIN, hinge	1
...	12	151 828	... PIN, cotter hair .054 x .750	2
...	13	173 616	... COVER, right angle motor	1
...	14	PM 173 435	... MOTOR, gear 24VDC 122RPM 20:1 ratio (consisting of)	1
...		193 633	... KEY, woodruff .118 x .380	1
...		193 634	... WASHER, wave .405 ID x .740 OD	2
...		193 635	... RING, rtng ext .394 shaft x	1
...	15	079 633	... FITTING, hose brs barbed M 3/16tbg	1
...	16	601 966	... SCREW, .375-16 x 1.25hexhd	2
...	18	604 538	... WASHER, flat stl SAE .312	1
...	19	124 778	... KNOB, plstc T 1.000 lg x .312-18 x 2.000 bar	1
...	20	173 619	... CARRIER, drive roll w/components	1
...	21	174 609	... SCREW, M 4-.7 x 12	1
...	22	174 610	... SCREW, M 6-1.0 x 20 soc hd	3
...	23	192 029	... WASHER, flat .250 ID x .437 OD	3
...	24	173 620	... BUSHING, motor mtg	3
...	25	602 243	... WASHER, flat .438 ID X 1.00 OD	1
...	26	602 213	... WASHER, lock .380 ID X .683 OD	1
...	27	085 244	... WASHER, cupped stl .328 ID x .812 OD x .125 lip	1
...		*045 233	... GUIDE, anti-wear	1

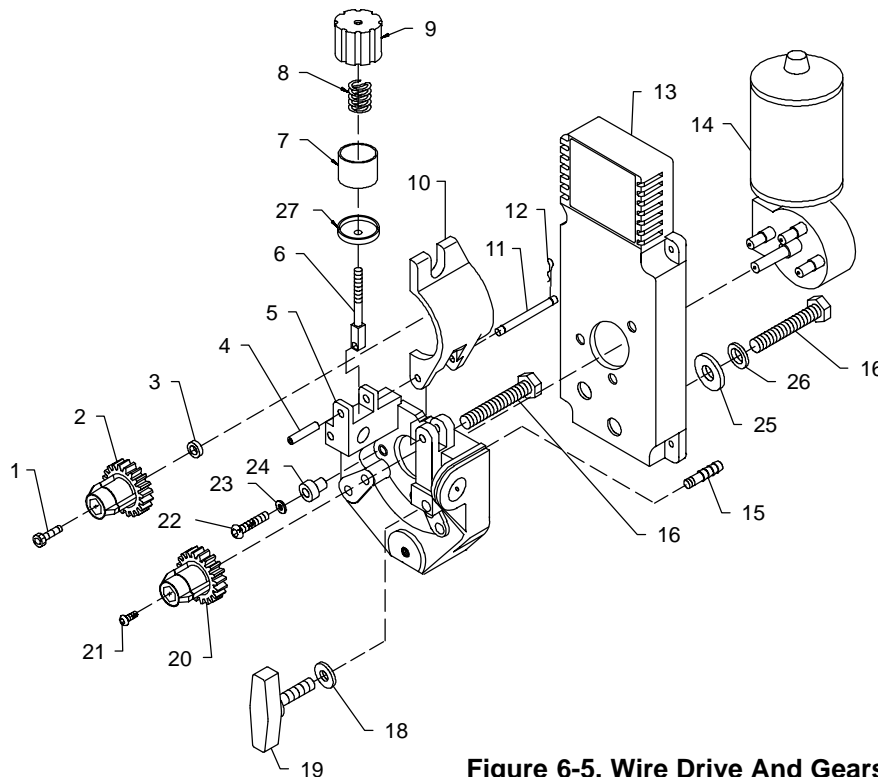

**See Table 6-1
Drive Roll & Wire Guide Kits.**

 Hardware is common and not available unless listed.

Figure 6-5. Wire Drive And Gears

148 529-J

*Recommended Spare Parts.

To maintain the factory original performance of your equipment, use only Manufacturer's Suggested Replacement Parts. Model and serial number required when ordering parts from your local distributor.

Table 6-1. Drive Roll And Wire Guide Kits

Note 

Base selection of drive rolls upon the following recommended usages:

- 1 V-Grooved rolls for hard wire.
- 2 U-Grooved rolls for soft and soft shelled cored wires.
- 3 U-Cogged rolls for extremely soft shelled wires (usually hard surfacing types).
- 4 V-Knurled rolls for hard shelled cored wires.
- 5 Drive roll types may be mixed to suit particular requirements (example: V-Knurled roll in combination with U-Grooved).

Wire Diameter			Kit No.	Drive Roll		Inlet Wire Guide
Fraction	Decimal	Metric		Part No.	Type	
.023/.025 in.	.023/.025 in.	0.6 mm	087 131	087 130	V-Grooved	056 192
.030 in.	.030 in.	0.8 mm	079 594	053 695	V-Grooved	056 192
.035 in.	.035 in.	0.9 mm	079 595	053 700	V-Grooved	056 192
.045 in.	.045 in.	1.2 mm	079 596	053 697	V-Grooved	056 193
.052 in.	.052	1.3 mm	079 597	053 698	V-Grooved	056 193
1/16 in.	.062	1.6 mm	079 598	053 699	V-Grooved	056 195

Ref. S-0026-B/7-91

Item No.	Dia. Mkgs.	Part No.	Description	Quantity
----------	------------	----------	-------------	----------

Figure 6-6. Panel, Rear w/Components (Fig 6-1 Item 3)

...	1	...	148 809	...	BLADE, fan 9 in 5wg 34deg .309 bore CCW	...	1
...	2	...	FM1 188 706	...	MOTOR, fan 230V 50/60 Hz 1550RPM .312dia shaft	...	1
...	3	...	203 711	...	WINDTUNNEL	...	1
...	4	...	GS1 125 785	...	VALVE, 24VAC 2 way custom port 1/8 orf	...	1
...	5	...	203 478	...	+PANEL, rear	...	1
...	6	...	169 654	...	+BRACKET, support tank	...	1
...		...	200 285	...	LABEL, warning cylinder may	...	1
...	7	...	188 441	...	CHAIN, weldless 2/0 x 31.000 lg	...	1
...	8	...	605 227	...	NUT, nyl hex jam .750NPST	...	1
...	9	...	604 102	...	CONNECTOR, clamp cable .690/1.070	...	1
...		...	193 328	...	LABEL, warning	...	1

 Hardware is common and not available unless listed.

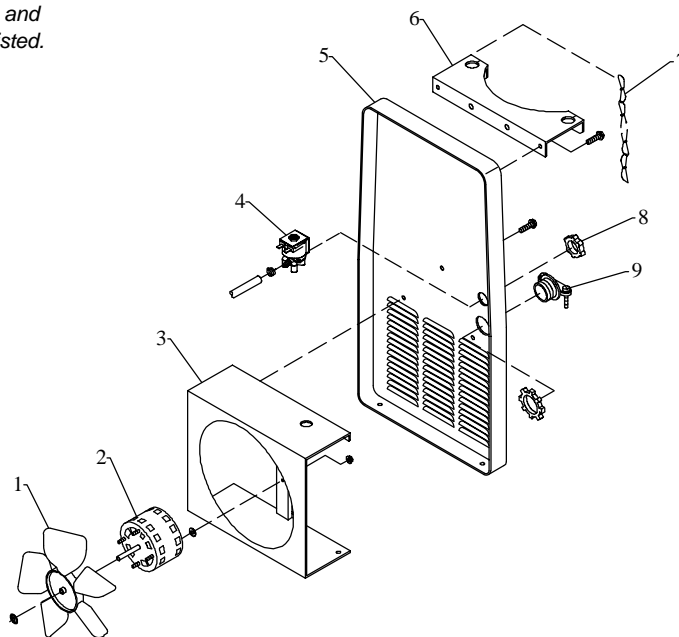

Figure 6-6. Panel, Rear w/Components

Ref. 802 088-A

+When ordering a component originally displaying a precautionary label, the label should also be ordered.
To maintain the factory original performance of your equipment, use only Manufacturer's Suggested Replacement Parts. Model and serial number required when ordering parts from your local distributor.

TRUE BLUE[®]

WARRANTY

Effective January 1, 2000

(Equipment with a serial number preface of "LA" or newer)

This limited warranty supersedes all previous Miller warranties and is exclusive with no other guarantees or warranties expressed or implied.

Warranty Questions?

Call
1-800-4-A-MILLER
for your local
Miller distributor.

Your distributor also gives
you ...

Service

You always get the fast,
reliable response you
need. Most replacement
parts can be in your
hands in 24 hours.

Support

Need fast answers to the
tough welding questions?
Contact your distributor.
The expertise of the
distributor and Miller is
there to help you, every
step of the way.

LIMITED WARRANTY – Subject to the terms and conditions below, Miller Electric Mfg. Co., Appleton, Wisconsin, warrants to its original retail purchaser that new Miller equipment sold after the effective date of this limited warranty is free of defects in material and workmanship at the time it is shipped by Miller. THIS WARRANTY IS EXPRESSLY IN LIEU OF ALL OTHER WARRANTIES, EXPRESS OR IMPLIED, INCLUDING THE WARRANTIES OF MERCHANTABILITY AND FITNESS.

Within the warranty periods listed below, Miller will repair or replace any warranted parts or components that fail due to such defects in material or workmanship. Miller must be notified in writing within thirty (30) days of such defect or failure, at which time Miller will provide instructions on the warranty claim procedures to be followed.

Miller shall honor warranty claims on warranted equipment listed below in the event of such a failure within the warranty time periods. All warranty time periods start on the date that the equipment was delivered to the original retail purchaser, or one year after the equipment is sent to a North American distributor or eighteen months after the equipment is sent to an International distributor.

1. 5 Years Parts – 3 Years Labor
 - * Original main power rectifiers
 - * Inverters (input and output rectifiers only)
2. 3 Years — Parts and Labor
 - * Transformer/Rectifier Power Sources
 - * Plasma Arc Cutting Power Sources
 - * Semi-Automatic and Automatic Wire Feeders
 - * Inverter Power Supplies
 - * Intelligig
 - * Engine Driven Welding Generators
(NOTE: Engines are warranted separately by the engine manufacturer.)
3. 1 Year — Parts and Labor
 - * DS-2 Wire Feeder
 - * Motor Driven Guns (w/exception of Spoolmate 185 & Spoolmate 250)
 - * Process Controllers
 - * Positioners and Controllers
 - * Automatic Motion Devices
 - * RFCS Foot Controls
 - * Induction Heating Power Sources
 - * Water Coolant Systems
 - * HF Units
 - * Grids
 - * Maxstar 140
 - * Spot Welders
 - * Load Banks
 - * Miller Cyclomatic Equipment
 - * Running Gear/Trailers
 - * Plasma Cutting Torches (except APT & SAF Models)
 - * Field Options
(NOTE: Field options are covered under True Blue[®] for the remaining warranty period of the product they are installed in, or for a minimum of one year — whichever is greater.)
4. 6 Months — Batteries
5. 90 Days — Parts
 - * MIG Guns/TIG Torches
 - * Induction Heating Coils and Blankets

- * APT, ZIPCUT & PLAZCUT Model Plasma Cutting Torches
- * Remote Controls
- * Accessory Kits
- * Replacement Parts (No labor)
- * Spoolmate 185 & Spoolmate 250
- * Canvas Covers

Miller's True Blue[®] Limited Warranty shall not apply to:

1. **Consumable components; such as contact tips, cutting nozzles, contactors, brushes, slip rings, relays or parts that fail due to normal wear.**
2. Items furnished by Miller, but manufactured by others, such as engines or trade accessories. These items are covered by the manufacturer's warranty, if any.
3. Equipment that has been modified by any party other than Miller, or equipment that has been improperly installed, improperly operated or misused based upon industry standards, or equipment which has not had reasonable and necessary maintenance, or equipment which has been used for operation outside of the specifications for the equipment.

MILLER PRODUCTS ARE INTENDED FOR PURCHASE AND USE BY COMMERCIAL/INDUSTRIAL USERS AND PERSONS TRAINED AND EXPERIENCED IN THE USE AND MAINTENANCE OF WELDING EQUIPMENT.

In the event of a warranty claim covered by this warranty, the exclusive remedies shall be, at Miller's option: (1) repair; or (2) replacement; or, where authorized in writing by Miller in appropriate cases, (3) the reasonable cost of repair or replacement at an authorized Miller service station; or (4) payment of or credit for the purchase price (less reasonable depreciation based upon actual use) upon return of the goods at customer's risk and expense. Miller's option of repair or replacement will be F.O.B., Factory at Appleton, Wisconsin, or F.O.B. at a Miller authorized service facility as determined by Miller. Therefore no compensation or reimbursement for transportation costs of any kind will be allowed.

TO THE EXTENT PERMITTED BY LAW, THE REMEDIES PROVIDED HEREIN ARE THE SOLE AND EXCLUSIVE REMEDIES. IN NO EVENT SHALL MILLER BE LIABLE FOR DIRECT, INDIRECT, SPECIAL, INCIDENTAL OR CONSEQUENTIAL DAMAGES (INCLUDING LOSS OF PROFIT), WHETHER BASED ON CONTRACT, TORT OR ANY OTHER LEGAL THEORY.

ANY EXPRESS WARRANTY NOT PROVIDED HEREIN AND ANY IMPLIED WARRANTY, GUARANTY OR REPRESENTATION AS TO PERFORMANCE, AND ANY REMEDY FOR BREACH OF CONTRACT TORT OR ANY OTHER LEGAL THEORY WHICH, BUT FOR THIS PROVISION, MIGHT ARISE BY IMPLICATION, OPERATION OF LAW, CUSTOM OF TRADE OR COURSE OF DEALING, INCLUDING ANY IMPLIED WARRANTY OF MERCHANTABILITY OR FITNESS FOR PARTICULAR PURPOSE, WITH RESPECT TO ANY AND ALL EQUIPMENT FURNISHED BY MILLER IS EXCLUDED AND DISCLAIMED BY MILLER.

Some states in the U.S.A. do not allow limitations of how long an implied warranty lasts, or the exclusion of incidental, indirect, special or consequential damages, so the above limitation or exclusion may not apply to you. This warranty provides specific legal rights, and other rights may be available, but may vary from state to state.

In Canada, legislation in some provinces provides for certain additional warranties or remedies other than as stated herein, and to the extent that they may not be waived, the limitations and exclusions set out above may not apply. This Limited Warranty provides specific legal rights, and other rights may be available, but may vary from province to province.





Owner's Record

Please complete and retain with your personal records.

Model Name	Serial/Style Number
Purchase Date	(Date which equipment was delivered to original customer.)
Distributor	
Address	
City	
State	Zip



For Service

Call 1-800-4-A-Miller or see our website at www.MillerWelds.com to locate a DISTRIBUTOR or SERVICE AGENCY near you.

Always provide Model Name and Serial/Style Number.

Contact your Distributor for:

- Welding Supplies and Consumables
- Options and Accessories
- Personal Safety Equipment
- Service and Repair
- Replacement Parts
- Training (Schools, Videos, Books)
- Technical Manuals (Servicing Information and Parts)
- Circuit Diagrams
- Welding Process Handbooks

Contact the Delivering Carrier for:

File a claim for loss or damage during shipment.

For assistance in filing or settling claims, contact your distributor and/or equipment manufacturer's Transportation Department.

Miller Electric Mfg. Co.

An Illinois Tool Works Company
1635 West Spencer Street
Appleton, WI 54914 USA

International Headquarters—USA

USA Phone: 920-735-4505 Auto-Attended
USA & Canada FAX: 920-735-4134
International FAX: 920-735-4125

European Headquarters – United Kingdom

Phone: 44 (0) 1204-593493
FAX: 44 (0) 1204-598066

www.MillerWelds.com

