



OM-1500-17

218 022G

2006-06

Processes



MIG (GMAW) Welding

Description



Semi-Automatic, Air-Cooled,
MIG (GMAW) Welding Gun



XRTM -A Python[®] 25 Ft.

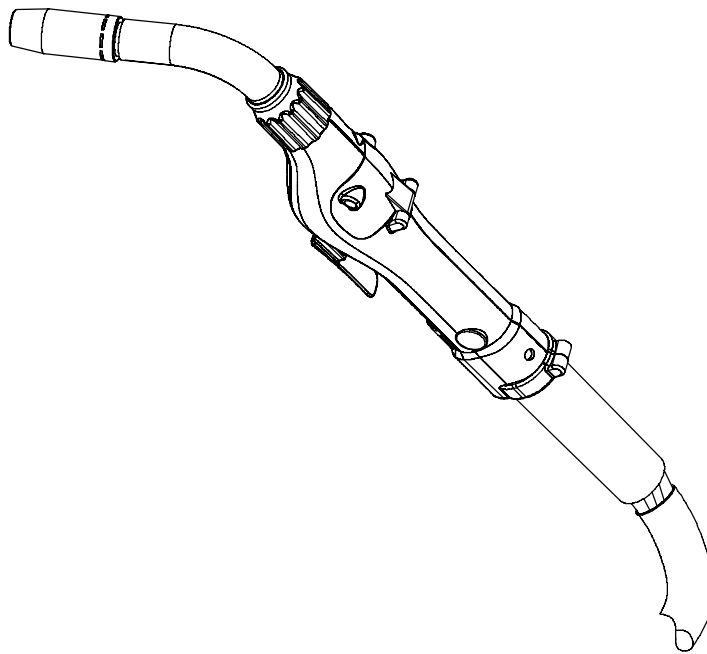

200 Ampere Push-Pull Welding Gun

OWNER'S MANUAL



Visit our website at
www.MillerWelds.com

File: MIG (GMAW)



From Miller to You

Thank you and congratulations on choosing Miller. Now you can get the job done and get it done right. We know you don't have time to do it any other way.

That's why when Niels Miller first started building arc welders in 1929, he made sure his products offered long-lasting value and superior quality. Like you, his customers couldn't afford anything less. Miller products had to be more than the best they could be. They had to be the best you could buy.

Today, the people that build and sell Miller products continue the tradition. They're just as committed to providing equipment and service that meets the high standards of quality and value established in 1929.

This Owner's Manual is designed to help you get the most out of your Miller products. Please take time to read the Safety precautions. They will help you protect yourself against potential hazards on the worksite.

We've made installation and operation quick and easy. With Miller you can count on years of reliable service with proper maintenance. And if for some reason the unit needs repair, there's a Troubleshooting section that will help you figure out what the problem is. The parts list will then help you to decide the exact part you may need to fix the problem. Warranty and service information for your particular model are also provided.



Miller is the first welding equipment manufacturer in the U.S.A. to be registered to the ISO 9001:2000 Quality System Standard.

Miller Electric manufactures a full line of welders and welding related equipment. For information on other quality Miller products, contact your local Miller distributor to receive the latest full line catalog or individual specification sheets. **To locate your nearest distributor or service agency call 1-800-4-A-Miller, or visit us at www.MillerWelds.com on the web.**



Working as hard as you do – every power source from Miller is backed by the most hassle-free warranty in the business.



TABLE OF CONTENTS

SECTION 1 – SAFETY PRECAUTIONS FOR GMAW WELDING GUNS – READ BEFORE USING	1
1-1. Symbol Usage	1
1-2. GMAW Gun Hazards	1
EMF INFORMATION	2
SECTION 2 – DEFINITIONS	3
2-1. Warning Label Definitions	3
2-2. Symbols And Definitions	4
SECTION 3 – INSTALLATION	5
3-1. Specifications	5
3-2. Gun Lead Connections	5
SECTION 4 – OPERATION	6
4-1. Controls and Settings	6
4-2. Drive Roll Removal/Installation	7
4-3. Idler Roll Removal/Installation	8
SECTION 5 – MAINTENANCE & TROUBLESHOOTING	9
5-1. Routine Maintenance	9
5-2. Troubleshooting Guide	9
5-3. Troubleshooting Table	10
SECTION 6 – ELECTRICAL DIAGRAMS	11
SECTION 7 – PARTS LIST	12
SECTION 8 – OPTIONS AND ACCESSORIES	18
WARRANTY	

Declaration of Conformity for European Community (CE) Products

NOTE



This information is provided for units with CE certification (see rating label on unit).

Manufacturer:

Miller Electric Mfg. Co.
1635 W. Spencer St.
Appleton, WI 54914 USA
Phone: (920) 734-9821

European Contact:

Mr. Danilo Fedolfi,
Managing Director
ITW Welding Products Italy S.r.l.
Via Privata Iseo 6/E
20098 San Giuliano
Milanese, Italy
Phone: 39(02)98290-1
Fax: 39(02)98290203

European Contact Signature: _____

Declares that the product:

Python®

conforms to the following Directives and Standards:

Directives

Low Voltage Directive: 73/23/EEC

Electromagnetic Compatibility (EMC) Directive: 89/336/EEC

Standards

Arc Welding Equipment – Part 5: Wire Feeders. IEC 60974-5 Ed. 1

Arc Welding Equipment – Part 10: Electromagnetic Compatibility (EMC) Requirements. IEC 60974-10 August 2002

Arc Welding Equipment – Part 1: Welding Power Sources. IEC 60974-1 Ed. 2.1

Degrees Of Protection Provided By Enclosure (IP Code) IEC 60529 Ed. 2.1

Insulation Coordination For Equipment Within Low-Voltage Systems –
Part 1: Principles, Requirements and Tests: IEC 60664-1 Ed. 1.1

Arc Welding Equipment – Part 7: Torches. IEC 60974-7 Ed.1

The product technical file is maintained by the responsible Business Unit(s) located at the manufacturing facility.

SECTION 1 –SAFETY PRECAUTIONS FOR GMAW WELDING GUNS – READ BEFORE USING

SR7_8/03

1-1. Symbol Usage



Means Warning! Watch Out! There are possible hazards with this procedure! The possible hazards are shown in the adjoining symbols.

▲ Marks a special safety message.

☞ Means NOTE; not safety related.



This group of symbols means Warning! Watch Out! Possible ELECTRIC SHOCK and HOT PARTS hazards. Consult symbols and related instructions below for necessary actions to avoid the hazards.

1-2. GMAW Gun Hazards



WARNING

GMAW WELDING can be hazardous.

PROTECT YOURSELF AND OTHERS FROM POSSIBLE SERIOUS INJURY OR DEATH. KEEP CHILDREN AWAY. PACEMAKER WEARERS KEEP AWAY UNTIL CONSULTING YOUR DOCTOR.

In welding, as in most jobs, exposure to certain hazards occurs. Welding is safe when precautions are taken. The safety information given below is only a summary of the more complete safety information found in the wire feeder and welding power source Owner's Manuals. Read and follow all safety precautions.

HAVE ALL INSTALLATION, OPERATION, MAINTENANCE, AND REPAIR WORK PERFORMED ONLY BY QUALIFIED PEOPLE.

	<p>ELECTRIC SHOCK can kill.</p> <ol style="list-style-type: none"> 1. Always wear dry insulating gloves. 2. Insulate yourself from work and ground. 3. Do not touch live electrode or electrical parts. 4. Repair or replace worn, damaged, or cracked gun or cable insulation. 5. Turn off welding power source before changing contact tip or gun parts. 6. Keep all covers and handle securely in place. 		<p>ARC RAYS can burn eyes and skin.</p> <ol style="list-style-type: none"> 1. Wear welding helmet with correct shade of filter. 2. Wear correct eye and body protection. 3. Cover exposed skin with spatter-resistant clothing.
	<p>FUMES AND GASES can be hazardous to your health.</p> <ol style="list-style-type: none"> 1. Keep your head out of the fumes. 2. Ventilate area, or use breathing device. 3. Read Material Safety Data Sheets (MSDSs) and manufacturer's instructions for material used. 		<p>HOT SURFACES can burn skin.</p> <ol style="list-style-type: none"> 1. Allow gun to cool before touching. 2. Do not touch hot metal. 3. Protect hot metal from contact by others.
	<p>WELDING can cause fire or explosion.</p> <ol style="list-style-type: none"> 1. Do not weld near flammable material. 2. Do not weld on closed containers. 3. Watch for fire; keep extinguisher nearby. 		<p>NOISE can damage hearing; SOME APPLICATIONS, SUCH AS PULSING, are noisy.</p> <ol style="list-style-type: none"> 1. Check for noise level limits exceeding those specified by OSHA. 2. Use approved ear plugs or ear muffs if noise level is high. 3. Warn others nearby about noise hazard.
	<p>BUILD UP OF GAS can injure or kill</p> <ol style="list-style-type: none"> 1. Shut off shielding gas supply when not in use. 2. Always ventilate confined spaces or use approved air-supplied respirator. 		<p>WELDING WIRE can cause puncture wounds.</p> <ol style="list-style-type: none"> 1. Keep hands and body away from gun tip when trigger is pressed.

EMF INFORMATION

NOTE



Considerations About Welding And The Effects Of Low Frequency Electric And Magnetic Fields

The following is a quotation from the General Conclusions Section of the U.S. Congress, Office of Technology Assessment, *Biological Effects of Power Frequency Electric & Magnetic Fields – Background Paper*, OTA-BP-E-53 (Washington, DC: U.S. Government Printing Office, May 1989): “. . . there is now a very large volume of scientific findings based on experiments at the cellular level and from studies with animals and people which clearly establish that low frequency magnetic fields can interact with, and produce changes in, biological systems. While most of this work is of very high quality, the results are complex. Current scientific understanding does not yet allow us to interpret the evidence in a single coherent framework. Even more frustrating, it does not yet allow us to draw definite conclusions about questions of possible risk or to offer clear science-based advice on strategies to minimize or avoid potential risks.”

To reduce magnetic fields in the workplace, use the following procedures:

1. Keep cables close together by twisting or taping them.
2. Arrange cables to one side and away from the operator.
3. Do not coil or drape cables around the body.
4. Keep welding power source and cables as far away as practical.
5. Connect work clamp to workpiece as close to the weld as possible.

About Pacemakers:

The above procedures are among those also normally recommended for pacemaker wearers. Consult your doctor for complete information.

mod10.1 4/93

SECTION 2 – DEFINITIONS





















2-1. Warning Label Definitions



- A. Warning! Watch Out! There are possible hazards as shown by the symbols.
- B. Drive rolls can injure fingers.
- C. Welding wire and drive parts are at welding voltage during operation – keep hands and metal objects clear.
- 1 Electric shock can kill.
 - 1.1 Wear dry insulating gloves. Do not touch electrode with bare hand. Do not wear wet or damaged gloves.
 - 1.2 Protect yourself from electric shock by insulating yourself from work and ground.
 - 1.3 Disconnect input plug or power before working on machine.
 - 2 Breathing welding fumes can be hazardous to your health.
 - 2.1 Keep your head out of the fumes.
 - 2.2 Use forced ventilation or local exhaust to remove the fumes.
 - 2.3 Use ventilating fan to remove fumes.
 - 3 Welding sparks can cause explosion or fire.
 - 3.1 Keep flammables away from welding. Don't weld near flammables.
 - 3.2 Welding sparks can cause fires. Have a fire extinguisher nearby and have a watch person ready to use it.
 - 3.3 Do not weld on drums or any closed containers.
 - 4 Arc rays can burn eyes and injure skin.
 - 4.1 Wear hat and safety glasses. Use ear protection and button shirt collar. Use welding helmet with correct shade of filter. Wear complete body protection.
 - 5 Become trained and read the instructions before working on the machine or welding.
 - 6 Do not remove or paint over (cover) the label.

2-2. Symbols And Definitions

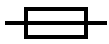
Note  Some symbols are found only on CE products.

A	Amperes	V	Volts		Alternating Current	X	Duty Cycle
IP	Degree Of Protection	Hz	Hertz		Circuit Breaker		Wire Feed
	Jog		Output		Trigger		Gun
	Press To Set		Increase		Trigger Hold On		Trigger Hold Off
	Purge		Spot Weld Time	%	Percent		Run-In
	Burnback Time	U₁	Primary Voltage	U₂	Load Voltage		Read Instructions
I₁	Primary Current	I₂	Rated Current		Line Connection		Water (Coolant) Input
	Water (Coolant) Output		Fuse		Continuous Spot Welding		

SECTION 3 – INSTALLATION

3-1. Specifications

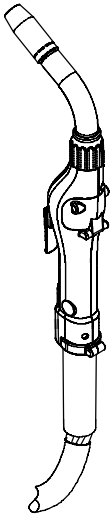
 <p style="text-align: right; font-size: small;">Ref. 803 870-A</p>	<p>Wire Capacity Aluminum wire - .030 in - 1/16 in (0.8 mm - 1.6 mm) using teflon liner Cored and Hard wire - .030 in - .045 in (0.6 mm - 1.2 mm) using spiral steel liner</p>
	<p>Wire Speed At rated feeder input voltage - 70-800 lpm (20.3 mpm)</p>
	<p>Duty Cycle - 100% (200 Amps peak) All ratings are based from using Argon gas</p>
	<p>Gun Weight Less leads – 2.5 lbs (1.13 kg)</p>
	<p>Shipping Weight Approximately 19.29 lbs (8.29 kg)</p>

3-2. Gun Lead Connections



Power Cable - A #2 AWG power cable is used. The gun end of the cable has a fitting crimped to the copper cable strands. This fitting is then threaded into the gun body. The cabinet end of the power cable is incorporated into the Power Pin connector.

Conduit - Poly-lined conduit, for feeding aluminum wire. The longer fitting with a shallow groove is used on the gun end. A set screw located on top of the gun handle secures the conduit in place. The cabinet end of the conduit is incorporated into the Power Pin connector.

Gas Hose - The gas hose is pushed over a barbed fitting on the gun body and secured with a plastic tie wrap. The cabinet end of the gas hose is incorporated into the Power Pin connector.

Electric Cable - A multi-conductor control cable is used. The gun end of the cable is secured with a cable clamp and the wires are connected to the potentiometer, the micro switch, the motor and the gun body mechanically. The cabinet end of the control cable uses a 10-Pin, Amphenol connector.

SECTION 4 – OPERATION

4-1. Controls and Settings

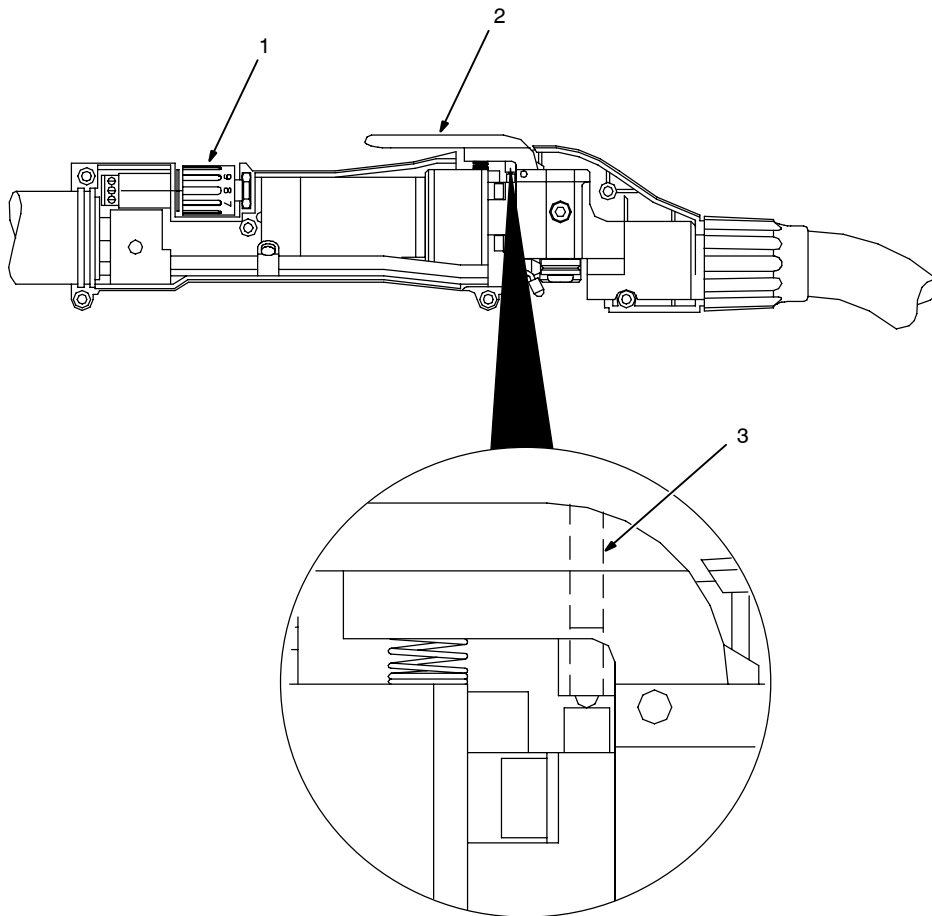

1 Potentiometer

The potentiometer is located in the lower end of the handle, providing up to 800 ipm (20.3 mpm) with 3 3/4 turns.

2 Trigger

3 Trigger Sensitivity Adjustment Screw

The amount of trigger level travel can be shortened for quicker response action.

A more sensitive trigger lever is produced by reducing the gap between the trigger lever and the micro switch lever. Turning the trigger sensitivity adjustment screw clockwise closes the gap between the trigger lever and the micro switch lever. This will enable the operator to increase the sensitivity of the trigger level.

Sensitivity adjustment - With the wire feeder turned on (with or without welding wire loaded), turn the screw clockwise until the micro-switch is activated. Once activated, the gun and wire feeder motors will begin feeding wire. Turn the screw counter clockwise until the system is deactivated and adjusted to the operators' liking.

Close top cover.

Tools Needed:

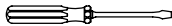

803 870-A

4-2. Drive Roll Removal/Installation

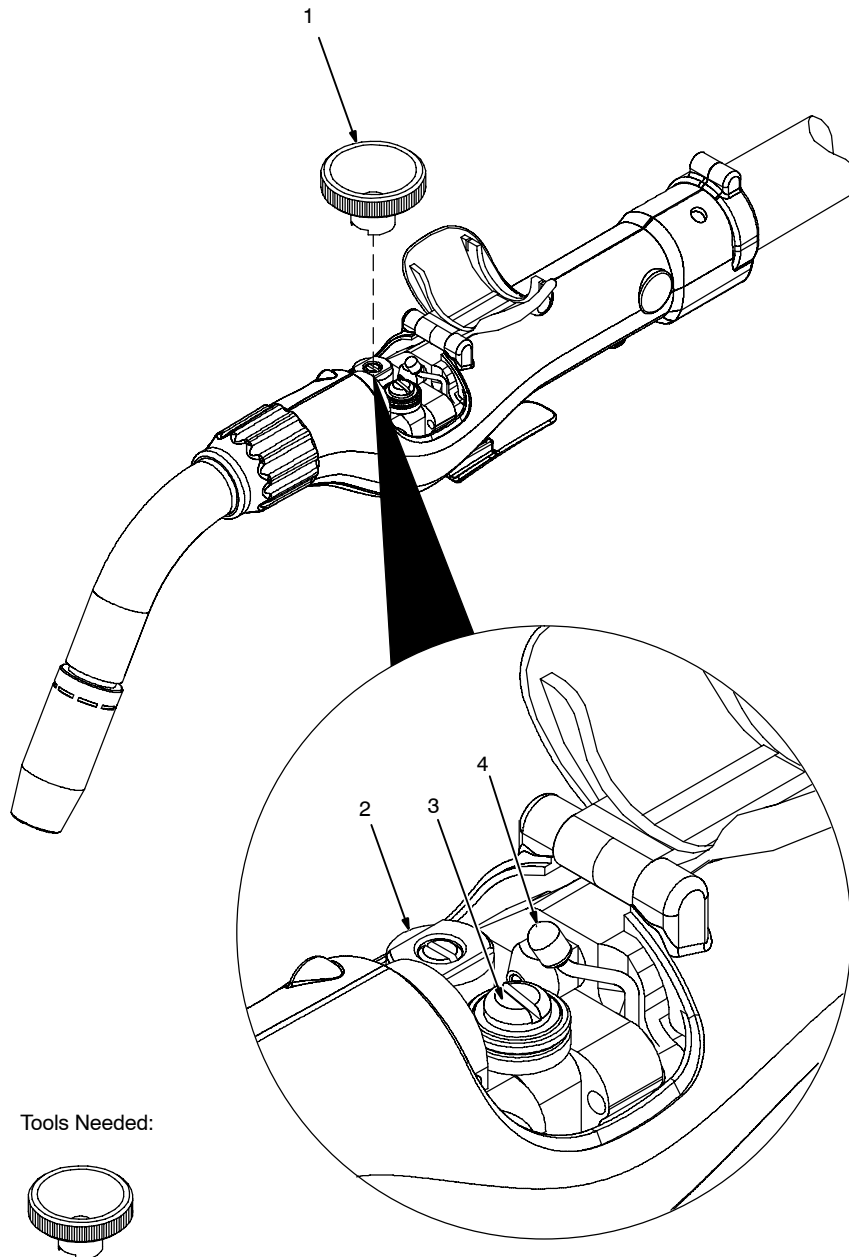
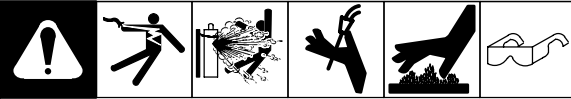

- 1 Drive Roll Removal Tool
P/N 215676
- 2 Drive Roll
- 3 Idler Roll
- 4 Cam Lever

☞ The gun handles do not need to be removed for access to the drive or idler rolls.

Drive Roll Removal/Installation

☞ For insulated drive roll kits see Section 8 Options and Accessories.

Pull cam lever away from idler roll. This relieves pressure against the drive roll.

Align drive roll removal tool over the flats of the drive roll as shown. Hold the gun with one hand or on a table top, with the other hand give the removal tool a quick snap-turn clockwise direction.

Once the drive roll is loose, continue to spin drive roll in the clockwise direction to remove the drive roll from the gun.

Install a new drive roll on the left-hand threaded shaft. The drive roll will self-tighten when it is feeding wire.

Close top cover.

Tools Needed:

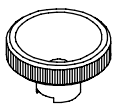

803 871-A / 803 872-A

4-3. Idler Roll Removal/Installation

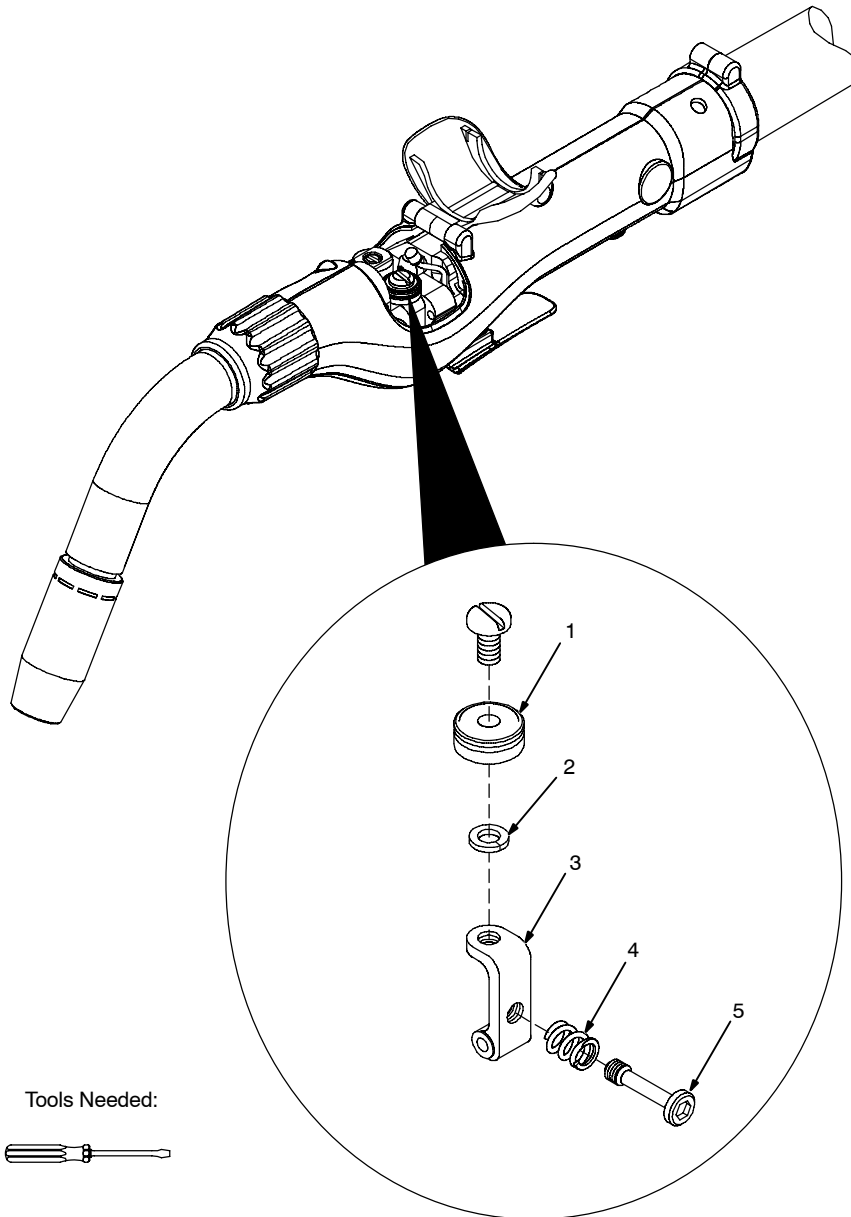
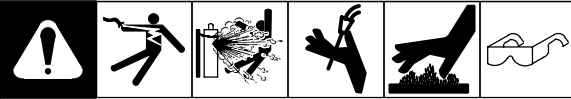

- 1 Idler Roll
- 2 Lockwasher
- 3 Idler Arm
- 4 Spring
- 5 Idler Screw

 The gun handles do not need to be removed for access to the drive or idler rolls.

Idler Roll Removal/Installation

Using a slot type screwdriver, loosen idler screw, taking care not to lose lock washer under idler roll.

Insert new idler roll and lock washer onto screw, insuring that idler groove is toward top and lock washer is beneath.

 Lock washer must be under idler roll or it will not turn freely.







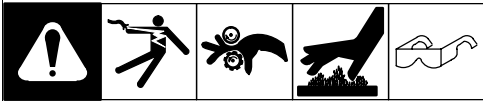
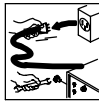

Tighten screw until tight.

Close top cover.

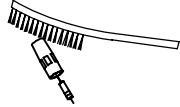
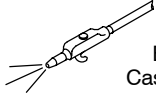
803 871-A / 803 872-A

SECTION 5 – MAINTENANCE & TROUBLESHOOTING

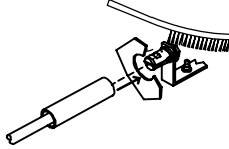
5-1. Routine Maintenance

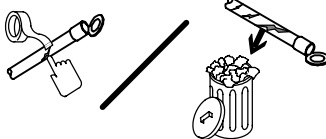
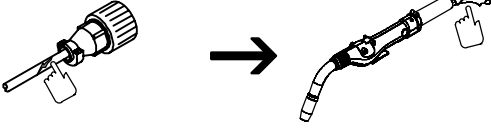
					 Disconnect power before maintaining.		 <i>Maintain more often during severe conditions.</i>	
Each Spool Of Wire								
 Clean Nozzle And Check Contact Tip				 Blow Out Gun Casing and Conduit				
 3 Months								
  Replace Damaged Or Unreadable Labels			 Clean And Tighten Weld Terminals			 Replace Damaged Gas Hose		
				 Repair Or Replace Cracked Cables And Cords				

5-2. Troubleshooting Guide





					 Disconnect power before troubleshooting.			
---	--	--	--	--	---	--	--	--

To aid in troubleshooting problems with your welding equipment, it is best to understand the basic theory of operation for this Push-Pull System. The push motor in the feeder runs at a fast, constant speed, but has very low torque. It is always trying to feed more wire than the gun motor wants, and when the motor gets all it wants, it slows the push motor, preventing a bird's nest. Because of the low torque produced by the push motor, a brake system rather than drag tension is used to prevent wire overrun when the motor stops. The drag adjustment in the feeder is used simply to keep the wire slightly taut, to prevent wire overrun while feeding wire.

The high torque 24VDC gun motor is controlled by a solid state speed control located in the feeder, and a pot located in the gun. The gun motor, potentiometer, and micro switch are connected to the cabinet/control box via a control cable and Amphenol connector. If this cable becomes damaged, a variety of symptoms can occur, depending on which wire(s) break. To test, check each wire for continuity and shorts.

Remember, the micro switch in the gun activates both the push motor and gun motor circuits in the cabinet. Therefore, if the push motor and brake solenoid operate, but the gun does not, look more toward the gun motor's 24VDC circuits, speed control, control cable, or the gun motor. If nothing operates, look more toward the push motor's input, micro switch leads, or micro switch.

5-3. Troubleshooting Table

					▲ Disconnect power before troubleshooting.
---	---	---	---	---	---

Trouble	Remedy
No wire feed at gun, feeder not operating. Check motor or brake solenoid.	Reset circuit breaker in feeder/control box. See feeder/control owner's manual.
	Replace micro-switch and test operation.
	Check micro-switch wires for continuity.
No wire feed at gun, feeder operating properly.	Reset circuit breaker in feeder/control box and check for short in motor leads. See feeder/control owner's manual.
	Check potentiometer with meter and replace if necessary.
	Check motor and potentiometer wires for continuity.
	See feeder/control owner's manual.
Wire feeds, but welding wire is not energized.	Clean and tighten all power connections.
	See feeder/control owner's manual.
	Check operation of welding power source.
Wire feeds erratically.	Check conduit for wear and obstruction and replace if necessary.
	Check contact tip for correct size and replace if necessary.
	Check for missing or damaged lock washer under idler roll.
Wire feeds one speed only.	Check potentiometer with meter and replace if necessary.
	Check continuity of welding gun wire feed speed potentiometer and replace if necessary.
	See feeder/control owner's manual.
Wire walks out of drive rolls.	Idler roll upside down, place groove in idler roll towards top.
	Rear wire guide missing, replace wire guide.

SECTION 6 – ELECTRICAL DIAGRAMS

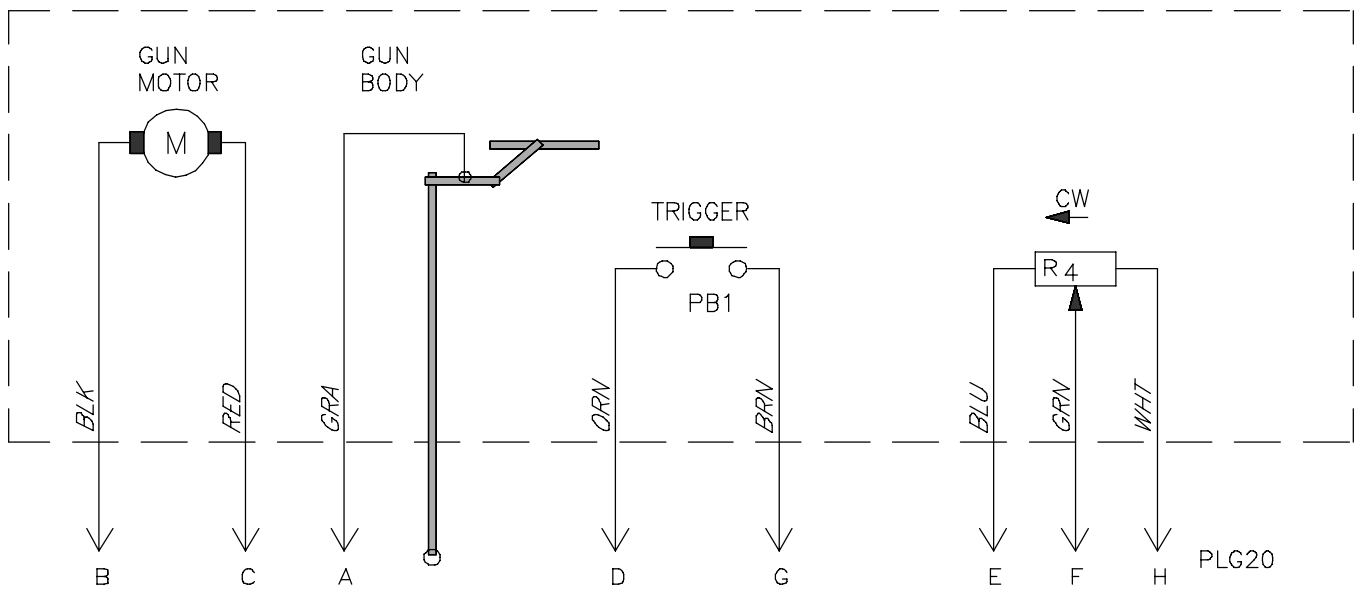

	WARNING
	<ul style="list-style-type: none"> • Do not touch live electrical parts. • Disconnect input power or stop engine before servicing. • Do not operate with covers removed. • Have only qualified persons install, use, or service this unit.
ELECTRIC SHOCK HAZARD	

Figure 6-1. Circuit Diagram For XR-A Python Gun

SECTION 7 - PARTS LIST

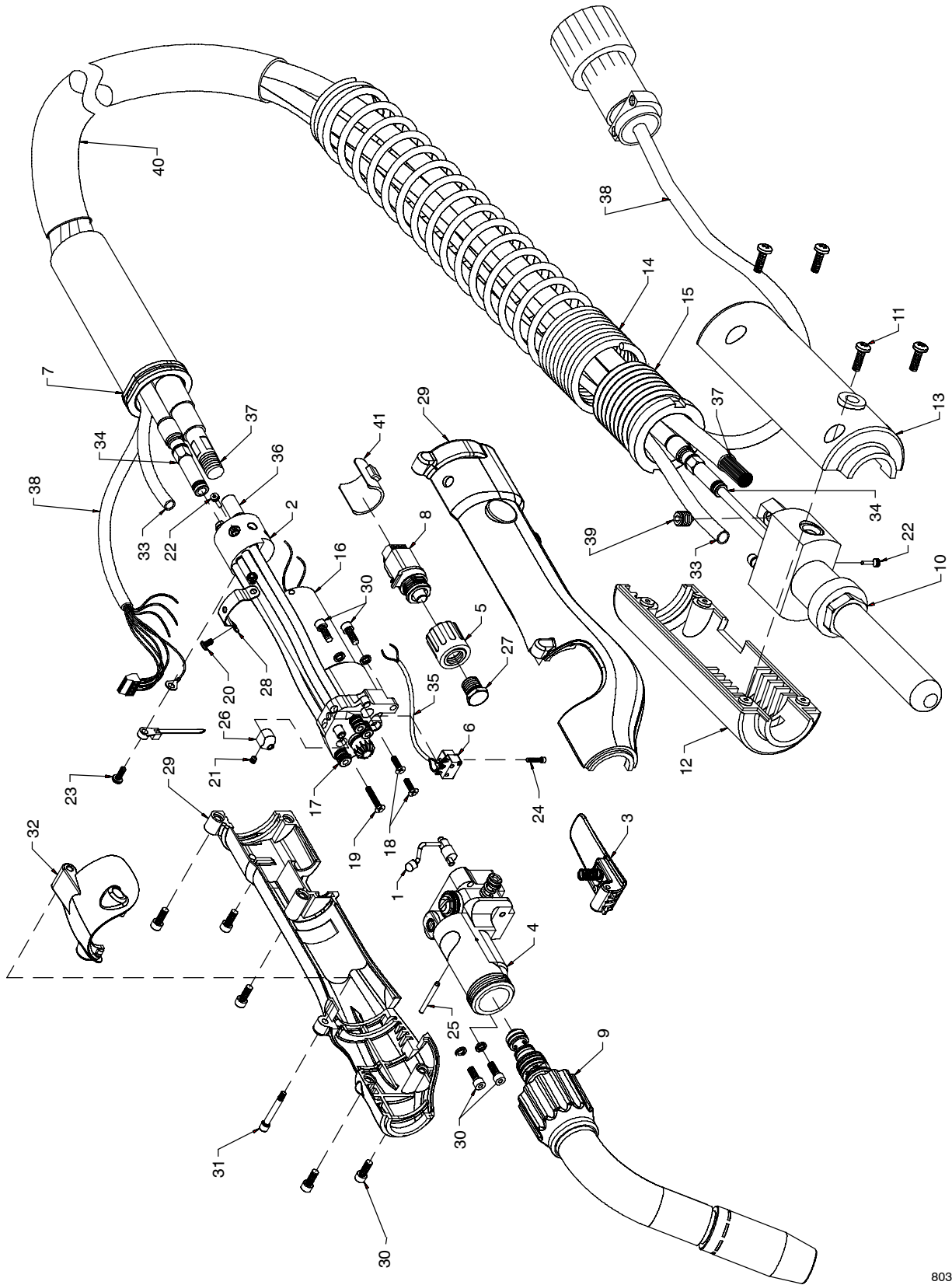

Figure 7-1. XR -A Python 25 Ft.

803 875-C

Item No.	Part No.	Description	Quantity
----------	----------	-------------	----------

Figure 7-1. XR -A Python 25 Ft.

1	220 688	Cam Idler Arm Assembly	1
2	220 689	Brazed Rear Body	1
3	*215 668	Trigger Kit	1
4	220 690	Front Body Assembly	1
5	220 691	Pot Knob Assembly	1
6	*215 671	Micro Switch Kit	1
7	220 692	Lead Assembly Boot	1
8	*215 670	Pot Assembly Kit	1
9	215 687	Barrel 60°	1
10	220 693	Power Pin Assembly	1
11	145 217	Screw K40 x 12	4
12	189 812	Housing, Power Pin Handle - Right	1
13	189 811	Housing, Power Pin Handle - Left	1
14	203 562	Strain Relief Spring	1
15	203 560	Spring Retainer	1
16	220 694	Motor	1
17	220 695	O-Ring 2-007 Buna N	6
18	220 696	Screw FH Phil 82 4-40 x 3/8 SST	2
19	220 697	Screw FH Phil 82 4-40 x 5/8 SST	1
20	220 698	Screw Button 4-40 x 3/16 ST	2
21	220 699	Set Screw #4-40 x 1/8 SST	1
22	220 700	Set Screw Mod	2
23	220 702	Screw PH Phil 4-40 x 5/16 SST	1
24	220 703	Screw SHC 1-72 x 3/8	1
25	220 704	Dowel Pin 3/32 x 7/8 SST	1
26	220 705	Wire Guide	1
27	220 707	Hex Screw 3/8 -20 x 3/8	1
28	220 712	Motor Strap	1
29	*215 665	Handle Kit Right/Left (Includes)	1
30	220 701	Screw SHC 6-32 x 3/8	9
31	220 706	Shoulder Screw 1/8 x 4-40	1
32	215 666	Molded Door	1
33	215 698	Gas Hose	1
34	*215 695	Conduit	1
35	220 713	Tube Insulation 9 AWG, Clear	0.30 FT
36	220 714	Cap Plug 0.218 ID x 0.50 LG	1
37	215 702	Power Cable	1
38	215 701	Control Cable	1
39	141 694	Screw, Set 312-18x .37 Conept Sch Stl Pln	1
40	215 703	25Ft Snake Skin, Cvr For Torch Leads	1
41	224 233	Cover, Potentiometer	1

*Recommended Spare Parts.

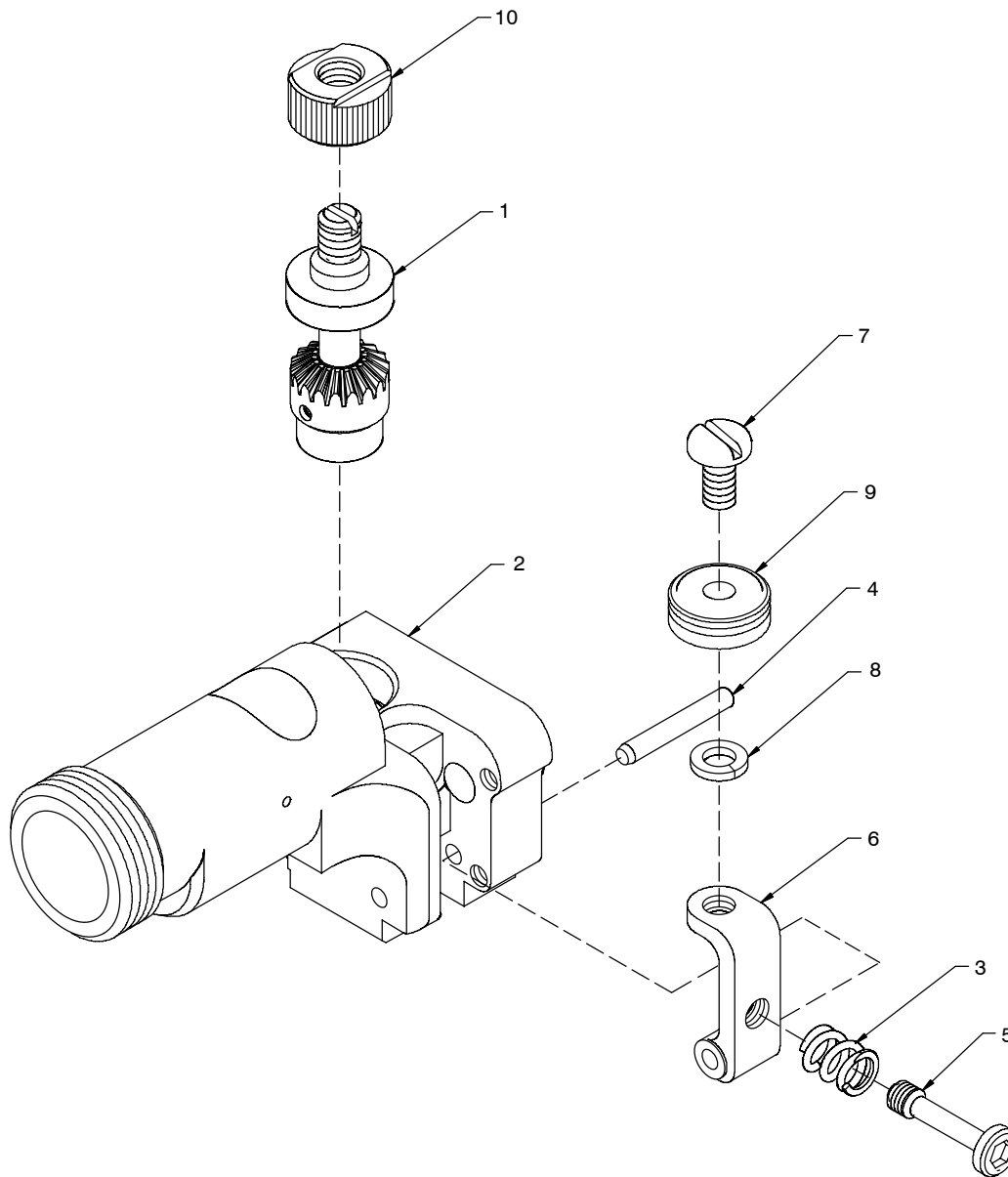

803 876-A

Figure 7-2. Front Body Assembly

Item No.	Part No.	Description	Quantity
Figure 7-2. Front Body Assembly			
1	220 715	Output Shaft Assembly	1
2	220 716	Body Assembly	1
3	220 719	0.29 x 0.047 x 0.32 Comp. Spring	1
4	220 720	1/8 x 7/8 SST Dowel Pin	1
5	220 721	Idler Adjusting Screw	1
6	220 722	Idler Arm	1
	215 674	Idler Roll Kit (Includes)	1
7	*220 717	10-24 x 3/8 PH Screw	1
8	*220 718	#10 Lockwasher	1
9	*220 723	Idler Wire Feed Assembly	1
10	*215 672	Drive Roll	1

*Recommended Spare Parts.

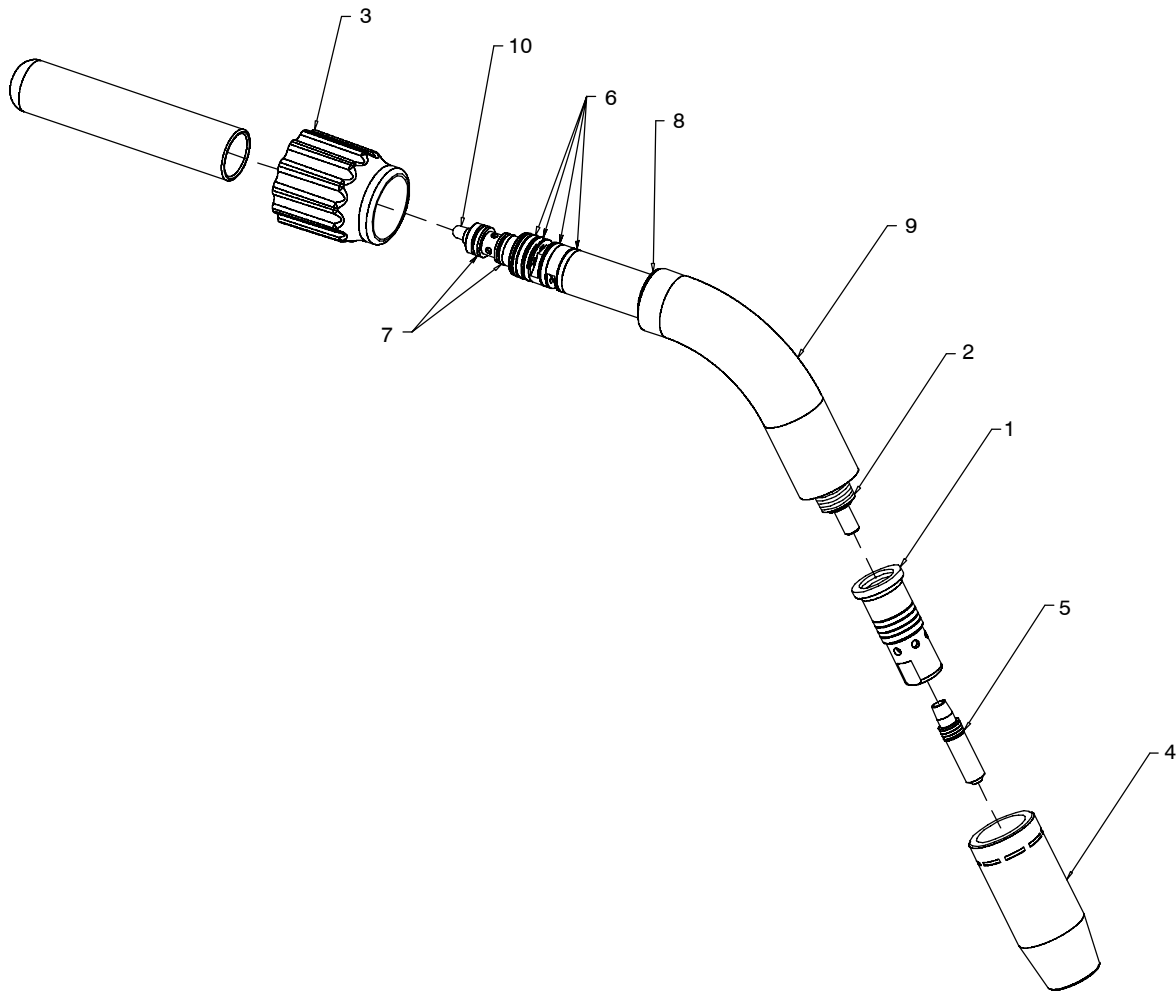

803 878-B

Figure 7-3. Barrel Assembly

Item No.	Part No.	Description	Quantity
----------	----------	-------------	----------

Figure 7-3. Barrel Assembly

.....	215 687	.. Barrel Assy, Air/Water Cooled 60 Deg (Includes)	1
... 1	*206 195	... Diffuser, 1/8 Tip Recess	1
... 2	220 724	... Assy Barrel Bend	1
... 3	220 725	... Assy Taper Lock Barrel	1
... 4	*198 855	... Nozzle, Copper, 5/8 in Orifice	1
... 5	*206 189052 Heavy Duty FasTip	1
... 6	215 693	... O-Ring, 0.489 Id x 0.629 Od	4
... 7	215 694	... O-Ring, 0.301 Id x 0.070 Wt	2
... 8	220 726	... Retaining Ring	1
... 9	220 727	... Barrel Insulator	1
... 10	*215 689	... Liner, Teflon Package - Used With Aluminum Wire	A/R
... 10	215 692	... Liner, Spiral Steel - Used With Steel and Hard Wires	A/R

*Recommended Spare Parts.

Item No.	Part No.	Description	Quantity
----------	----------	-------------	----------

Figure 7-3. Barrel Assembly Consumables Flowchart

Nozzles

... 4	◆ 176 238	.. Nozzle, Spot Flat	1
... 4	◆ 176 240	.. Nozzle, Spot Inside Corner	1
... 4	◆ 176 242	.. Nozzle, Spot Outside Corner	1
... 4	199 610	.. Nozzle, Screw On Brass 1/2 In Orifice	1
... 4	199 611	.. Nozzle, Screw On Brass 3/4 In Orifice Straight	1
... 4	199 612	.. Nozzle, Screw On Brass 3/4 In Orifice Straight Heavy Duty	1
... 4	199 613	.. Nozzle, Screw On Brass 5/8 In Orifice	1
... 4	199 614	.. Nozzle, Screw On Brass 5/8 In Orifice Heavy Duty	1
... 4	199 615	.. Nozzle, Screw On Copper 1/2 In Orifice	1
... 4	199 616	.. Nozzle, Screw On Copper 3/4 In Orifice	1
... 4	199 617	.. Nozzle, Screw On Copper 3/4 In Orifice Heavy Duty	1
... 4	198 855	.. Nozzle, Screw On Copper 5/8 In Orifice (Standard On 300 & 400 Amp Models)	1
... 4	199 618	.. Nozzle, Screw On Copper 5/8 In Orifice Heavy Duty (Standard On 500 & 600 Amp Models)	1
... 4	207 313	.. Nozzle, Screw On Copper 5/8 In Orifice 15/16 Od	1
... 4	◆◆ 209 035	.. Nozzle, Screw On Copper 3/8 In Orifice Tapered	1
... 4	◆◆ 209 036	.. Nozzle, Screw On Copper 1/2 In Orifice Tapered	1

Heavy Duty FasTip™ Contact Tips*

... 5	206 186	.. .035 in (0.9 mm) / .030 in (0.8 mm) Aluminum Wire	1
... 5	206 187	.. .040 in (1.0 mm) / .035 in (0.9 mm) Aluminum Wire	1
... 5	206 188	.. .045 in (1.2 mm) / .040 in (1.0 mm) Aluminum Wire	1
... 5	206 189	.. .052 in (1.3 mm) or 3/64 in (1.2 mm) Aluminum Wire	1
... 5	206 190	.. 1/16 in (1.6 mm)	1
... 5	206 191	.. .068 in (1.7 mm) or 1/16 in (1.6 mm) Aluminum Wire	1

Tapered FasTip™ Contact Tips*

... 5	209 026	.. .035 in (0.9 mm) / .030 in (0.8 mm) Aluminum Wire	1
... 5	209 027	.. .045 in (1.2 mm) / .035 in (0.9 mm) Aluminum Wire	1
... 5	209 028	.. 3/64 in (1.2 mm)	1
... 5	209 029	.. .052 in (1.3 mm)	1
... 5	209 030	.. 1/16 in (1.6 mm)	1

Gas Diffusers

... 1	206 195	.. 1/8 In Tip Recess – For Heavy Duty FasTip Contact Tips (Standard On All Guns)	1
... 1	210 664	.. 1/4 In Tip Recess – For Heavy Duty FasTip Contact Tips	1
... 1	206 196	.. Flush Tip – For Heavy Duty FasTip Contact Tips	1

◆ Requires diffuser 209099, used with any heavy duty FasTip™ contact tip.

◆◆ Requires diffuser 206195, 206196 or 210664, used with any tapered FasTip™ contact tip.

BE SURE TO PROVIDE MODEL WHEN ORDERING REPLACEMENT PARTS.

To maintain the factory original performance of your equipment, use only Manufacturer's Suggested Replacement Parts. Model is required when ordering parts from your local distributor.

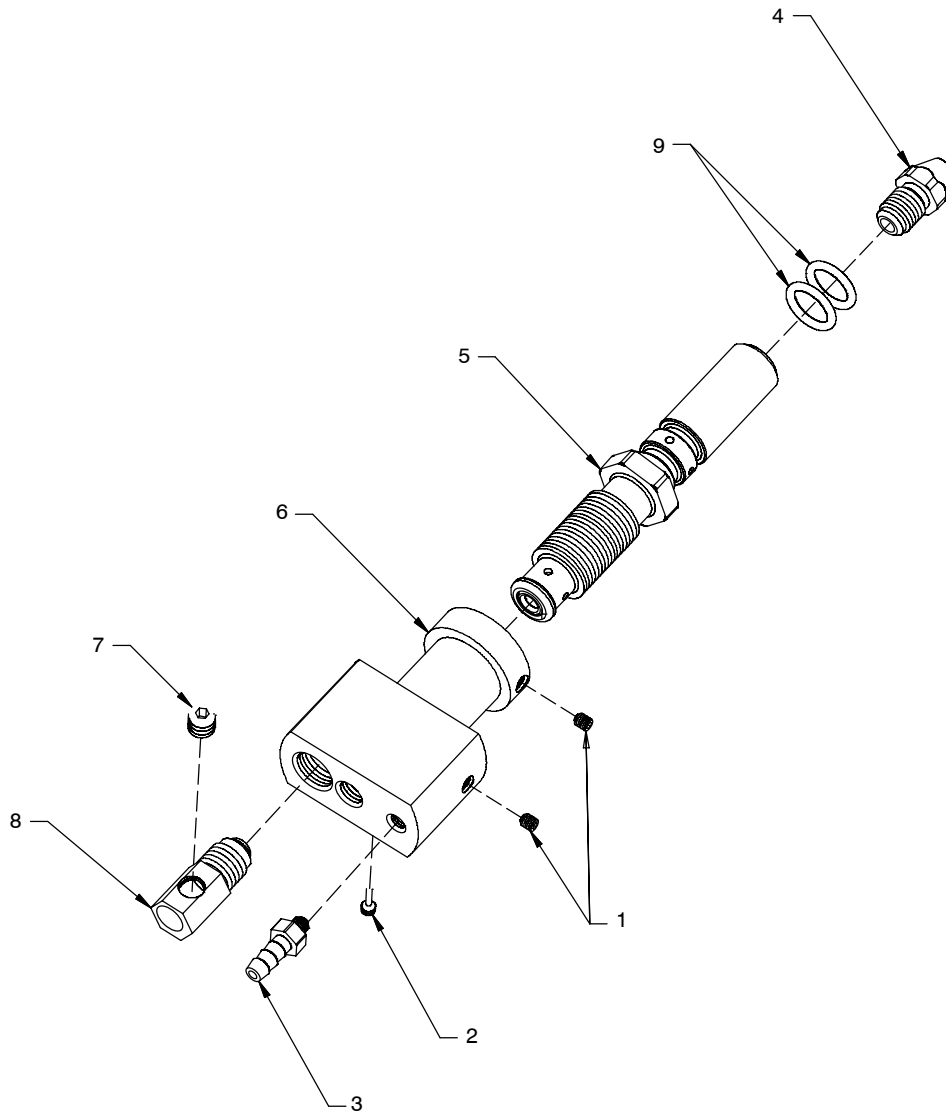

803 877-B

Figure 7-4. Power/Gas Connector

Item No.	Part No.	Description	Quantity
Figure 7-4. Power/Gas Connector			
1	602 172	Set Screw, 10-32 x 18	2
2	220 700	Set Screw Mod	1
3	202 513	Gas Hose Fitting	1
4	226 445	Guide, Wire Outlet .030-1/16	1
5	193 896	Power Pin Assembly	1
6	220 729	Power Gas Connector	1
7	141 694	Set Screw, 5/16-18 x 0.37	1
8	137 495	Power Weld Fitting	1
9	079 974	O-Ring, 0.5 Id	2

SECTION 8 – OPTIONS AND ACCESSORIES

Insulated Drive Roll Kits

Used to prevent preheating of the wire which may soften it and clog the liner. This picking up of current at the drive rolls rather than at the contact tip is usually not a problem unless using too large of a contact tip or excessively oxidized aluminum wire.

Insulated groove drive roll kits include insulated drive roll and idler roll assembly.

Wire Size	Part Number
0.030 (0.8mm)	215677
0.035 (0.9mm)	215678
0.045 (1.2mm)	215681
0.062 (1.6mm)	215684

TRUE BLUE[®]

WARRANTY

Effective January 1, 2006

(Equipment with a serial number preface of "LG" or newer)

This limited warranty supersedes all previous Miller warranties and is exclusive with no other guarantees or warranties expressed or implied.

Warranty Questions?

Call
1-800-4-A-MILLER
for your local
Miller distributor.

Your distributor also gives
you ...

Service

You always get the fast,
reliable response you
need. Most replacement
parts can be in your
hands in 24 hours.

Support

Need fast answers to the
tough welding questions?
Contact your distributor.
The expertise of the
distributor and Miller is
there to help you, every
step of the way.

LIMITED WARRANTY – Subject to the terms and conditions below, Miller Electric Mfg. Co., Appleton, Wisconsin, warrants to its original retail purchaser that new Miller equipment sold after the effective date of this limited warranty is free of defects in material and workmanship at the time it is shipped by Miller. THIS WARRANTY IS EXPRESSLY IN LIEU OF ALL OTHER WARRANTIES, EXPRESS OR IMPLIED, INCLUDING THE WARRANTIES OF MERCHANTABILITY AND FITNESS.

Within the warranty periods listed below, Miller will repair or replace any warranted parts or components that fail due to such defects in material or workmanship. Miller must be notified in writing within thirty (30) days of such defect or failure, at which time Miller will provide instructions on the warranty claim procedures to be followed.

Miller shall honor warranty claims on warranted equipment listed below in the event of such a failure within the warranty time periods. All warranty time periods start on the date that the equipment was delivered to the original retail purchaser, or one year after the equipment is sent to a North American distributor or eighteen months after the equipment is sent to an International distributor.

1. 5 Years Parts — 3 Years Labor
 - * Original main power rectifiers
2. 3 Years — Parts and Labor
 - * Transformer/Rectifier Power Sources
 - * Plasma Arc Cutting Power Sources
 - * Process Controllers
 - * Semi-Automatic and Automatic Wire Feeders
 - * Inverter Power Sources (Unless Otherwise Stated)
 - * Water Coolant Systems (Integrated)
 - * Intellitig
 - * Engine Driven Welding Generators
(NOTE: Engines are warranted separately by the engine manufacturer.)
3. 1 Year — Parts and Labor Unless Specified
 - * Motor Driven Guns (w/exception of Spoolmate Spoolguns)
 - * Positioners and Controllers
 - * Automatic Motion Devices
 - * RFCS Foot Controls
 - * Induction Heating Power Sources, Coolers, and Electronic Controls/Recorders
 - * Water Coolant Systems (Non-Integrated)
 - * Flowgauge and Flowmeter Regulators (No Labor)
 - * HF Units
 - * Grids
 - * Spot Welders
 - * Load Banks
 - * Arc Stud Power Sources & Arc Stud Guns
 - * Racks
 - * Running Gear/Trailers
 - * Plasma Cutting Torches (except APT & SAF Models)
 - * Field Options
(NOTE: Field options are covered under True Blue[®] for the remaining warranty period of the product they are installed in, or for a minimum of one year — whichever is greater.)
 - * Bernard-Branded Mig Guns (No Labor)
 - * Weldcraft-Branded TIG Torches (No Labor)
 - * Subarc Wire Drive Assemblies
4. 6 Months — Batteries
5. 90 Days — Parts
 - * MIG Guns/TIG Torches and Subarc (SAW) Guns

- * Induction Heating Coils and Blankets, Cables, and Non-Electronic Controls
- * APT & SAF Model Plasma Cutting Torches
- * Remote Controls
- * Accessory (Kits)
- * Replacement Parts (No labor)
- * Spoolmate Spoolguns
- * Canvas Covers

Miller's True Blue[®] Limited Warranty shall not apply to:

1. **Consumable components; such as contact tips, cutting nozzles, contactors, brushes, slip rings, relays or parts that fail due to normal wear. (Exception: brushes, slip rings, and relays are covered on Bobcat, Trailblazer, and Legend models.)**
2. Items furnished by Miller, but manufactured by others, such as engines or trade accessories. These items are covered by the manufacturer's warranty, if any.
3. Equipment that has been modified by any party other than Miller, or equipment that has been improperly installed, improperly operated or misused based upon industry standards, or equipment which has not had reasonable and necessary maintenance, or equipment which has been used for operation outside of the specifications for the equipment.

MILLER PRODUCTS ARE INTENDED FOR PURCHASE AND USE BY COMMERCIAL/INDUSTRIAL USERS AND PERSONS TRAINED AND EXPERIENCED IN THE USE AND MAINTENANCE OF WELDING EQUIPMENT.

In the event of a warranty claim covered by this warranty, the exclusive remedies shall be, at Miller's option: (1) repair; or (2) replacement; or, where authorized in writing by Miller in appropriate cases, (3) the reasonable cost of repair or replacement at an authorized Miller service station; or (4) payment of or credit for the purchase price (less reasonable depreciation based upon actual use) upon return of the goods at customer's risk and expense. Miller's option of repair or replacement will be F.O.B., Factory at Appleton, Wisconsin, or F.O.B. at a Miller authorized service facility as determined by Miller. Therefore no compensation or reimbursement for transportation costs of any kind will be allowed.

TO THE EXTENT PERMITTED BY LAW, THE REMEDIES PROVIDED HEREIN ARE THE SOLE AND EXCLUSIVE REMEDIES. IN NO EVENT SHALL MILLER BE LIABLE FOR DIRECT, INDIRECT, SPECIAL, INCIDENTAL OR CONSEQUENTIAL DAMAGES (INCLUDING LOSS OF PROFIT), WHETHER BASED ON CONTRACT, TORT OR ANY OTHER LEGAL THEORY.

ANY EXPRESS WARRANTY NOT PROVIDED HEREIN AND ANY IMPLIED WARRANTY, GUARANTY OR REPRESENTATION AS TO PERFORMANCE, AND ANY REMEDY FOR BREACH OF CONTRACT TORT OR ANY OTHER LEGAL THEORY WHICH, BUT FOR THIS PROVISION, MIGHT ARISE BY IMPLICATION, OPERATION OF LAW, CUSTOM OF TRADE OR COURSE OF DEALING, INCLUDING ANY IMPLIED WARRANTY OF MERCHANTABILITY OR FITNESS FOR PARTICULAR PURPOSE, WITH RESPECT TO ANY AND ALL EQUIPMENT FURNISHED BY MILLER IS EXCLUDED AND DISCLAIMED BY MILLER.

Some states in the U.S.A. do not allow limitations of how long an implied warranty lasts, or the exclusion of incidental, indirect, special or consequential damages, so the above limitation or exclusion may not apply to you. This warranty provides specific legal rights, and other rights may be available, but may vary from state to state.

In Canada, legislation in some provinces provides for certain additional warranties or remedies other than as stated herein, and to the extent that they may not be waived, the limitations and exclusions set out above may not apply. This Limited Warranty provides specific legal rights, and other rights may be available, but may vary from province to province.





Owner's Record

Please complete and retain with your personal records.

Model Name

Serial/Style Number

Purchase Date

(Date which equipment was delivered to original customer.)

Distributor

Address

City

State

Zip



For Service

Contact a DISTRIBUTOR or SERVICE AGENCY near you.

Always provide Model Name and Serial/Style Number.

Contact your Distributor for:

Welding Supplies and Consumables

Options and Accessories

Personal Safety Equipment

Service and Repair

Replacement Parts

Training (Schools, Videos, Books)

Technical Manuals (Servicing Information and Parts)

Circuit Diagrams

Welding Process Handbooks

To locate a Distributor or Service Agency visit www.millerwelds.com or call 1-800-4-A-Miller

Contact the Delivering Carrier to:

File a claim for loss or damage during shipment.

For assistance in filing or settling claims, contact your distributor and/or equipment manufacturer's Transportation Department.

Miller Electric Mfg. Co.

An Illinois Tool Works Company
1635 West Spencer Street
Appleton, WI 54914 USA

International Headquarters—USA

USA Phone: 920-735-4505 Auto-Attended
USA & Canada FAX: 920-735-4134
International FAX: 920-735-4125

European Headquarters – United Kingdom

Phone: 44 (0) 1204-593493
FAX: 44 (0) 1204-598066

www.MillerWelds.com

