



OM-225 429D

2015-09

**Processes**



TIG (GTAW) Welding

**Description**



*Hand-Held Water-Cooled TIG  
(GTAW) Torch*

## W-350 Series (WP-18 Series)

W-350 (WP- 18)

W-350V (WP-18V)

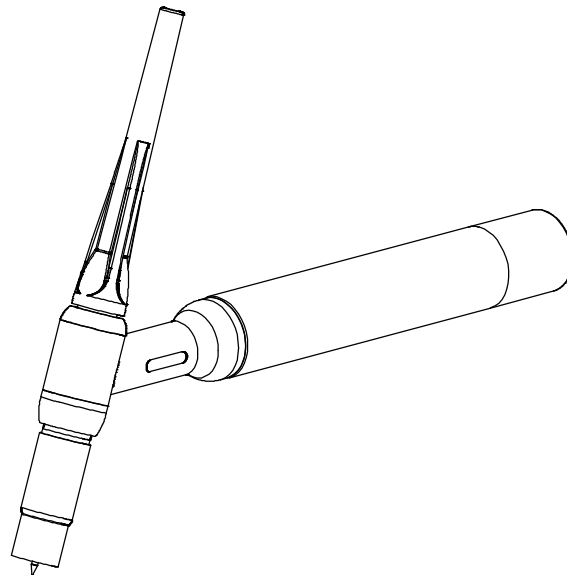

Visit our website at  
[www.MillerWelds.com](http://www.MillerWelds.com)

# OWNER'S MANUAL

File: TIG (GTAW)



# From Miller to You

---

*Thank you and congratulations* on choosing Miller. Now you can get the job done and get it done right. We know you don't have time to do it any other way.

That's why when Niels Miller first started building arc welders in 1929, he made sure his products offered long-lasting value and superior quality. Like you, his customers couldn't afford anything less. Miller products had to be more than the best they could be. They had to be the best you could buy.

Today, the people that build and sell Miller products continue the tradition. They're just as committed to providing equipment and service that meets the high standards of quality and value established in 1929.

This Owner's Manual is designed to help you get the most out of your Miller products. Please take time to read the Safety precautions. They will help you protect yourself against potential hazards on the worksite. We've made installation and operation quick and easy. With Miller you can count on years of reliable service with proper maintenance. And if for some reason the unit needs repair, there's a Troubleshooting section that will help you figure out what the problem is. The parts list will then help you to decide which exact part you may need to fix the problem. Warranty and service information for your particular model are also provided.



Miller Electric manufactures a full line of welders and welding related equipment. For information on other quality Miller products, contact your local Miller distributor to receive the latest full line catalog or individual catalog sheets.



Working as hard as you do – every power source from Miller is backed by the most hassle-free warranty in the business.



# TABLE OF CONTENTS

---

<b>SECTION 1 – SAFETY PRECAUTIONS FOR GTAW TORCHES – READ BEFORE USING</b> .....	<b>1</b>
1-1. Symbol Usage .....	1
1-2. Arc Welding Hazards .....	1
1-3. Proposition 65 Warnings .....	2
1-4. Principal Safety Standards .....	2
1-5. EMF Information .....	2
<b>SECTION 2 – CONSIGNES DE SÉCURITÉ – LIRE AVANT UTILISATION</b> .....	<b>3</b>
2-1. Signification des symboles .....	3
2-2. Dangers relatifs au soudage à l'arc .....	3
2-3. Proposition californienne 65 Avertissements .....	4
2-4. Principales normes de sécurité .....	4
2-5. Informations relatives aux CEM .....	4
<b>SECTION 3 – SPECIFICATIONS</b> .....	<b>5</b>
3-1. Specifications .....	5
3-2. Duty Cycle .....	5
<b>SECTION 4 – INSTALLATION</b> .....	<b>6</b>
4-1. Required Torch Parts And Torch Assembly .....	6
4-2. International Style Connector Assembly .....	6
4-3. Connecting Torch .....	7
<b>SECTION 5 – MAINTENANCE &amp; TROUBLESHOOTING</b> .....	<b>10</b>
5-1. Routine Maintenance .....	10
5-2. Troubleshooting .....	11
<b>SECTION 6 – SELECTING AND PREPARING A TUNGSTEN FOR DC OR AC WELDING</b> .....	<b>13</b>
6-1. Selecting Tungsten Electrode (Wear Clean Gloves To Prevent Contamination Of Tungsten) .....	13
6-2. Preparing Tungsten Electrode For Welding With Phase Control Machines .....	13
<b>SECTION 7 – GUIDELINES FOR TIG WELDING (GTAW)</b> .....	<b>14</b>
7-1. Positioning The Torch .....	14
7-2. Torch Movement During Welding .....	15
7-3. Positioning Torch Tungsten For Various Weld Joints .....	15
<b>SECTION 8 – PARTS LIST</b> .....	<b>16</b>
<b>WARRANTY</b>	



# SECTION 1 –SAFETY PRECAUTIONS FOR GTAW TORCHES – READ BEFORE USING

SR6 (TIG) 2015-09

**!** Protect yourself and others from injury — read, follow, and save these important safety precautions and operating instructions.

## 1-1. Symbol Usage



**DANGER!** – Indicates a hazardous situation which, if not avoided, will result in death or serious injury. The possible hazards are shown in the adjoining symbols or explained in the text.



Indicates a hazardous situation which, if not avoided, could result in death or serious injury. The possible hazards are shown in the adjoining symbols or explained in the text.

**NOTICE** – Indicates statements not related to personal injury.

 Indicates special instructions.



This group of symbols means Warning! Watch Out! ELECTRIC SHOCK, MOVING PARTS, and HOT PARTS hazards. Consult symbols and related instructions below for necessary actions to avoid the hazards.

## 1-2. Arc Welding Hazards



The symbols shown below are used throughout this manual to call attention to and identify possible hazards. When you see the symbol, watch out, and follow the related instructions to avoid the hazard. The safety information given below is only a summary of the more complete safety information found in the welding power source Owner's Manual. Read and follow all Safety Standards.



Only qualified persons should install, operate, maintain, and repair this unit.



During operation, keep everybody, especially children, away.



### ELECTRIC SHOCK can kill.

- Always wear dry insulating gloves.
- Insulate yourself from work and ground.
- Do not touch live electrode or electrical parts.
- Before welding, verify torch head is firmly attached to the torch body.
- Do not wrap water-cooled torch hoses and power cables together with tape or plastic wire ties. Wrapping restricts water flow which can cause power cable to overheat and torch hose to burst.
- Replace worn, damaged, or cracked torches or cables.
- Turn off welding power source before changing tungsten electrode or torch parts.
- Keep all covers and handle securely in place.



### ARC RAYS can burn eyes and skin.

Arc rays from the welding process produce intense visible and invisible (ultraviolet and infrared) rays that can burn eyes and skin. Sparks fly off from the weld.

- Wear an approved welding helmet fitted with a proper shade of filter lenses to protect your face and eyes from arc rays and sparks when welding or watching (see ANSI Z49.1 and Z87.1 listed in Safety Standards).
- Wear approved safety glasses with side shields under your helmet.
- Use protective screens or barriers to protect others from flash, glare and sparks; warn others not to watch the arc.
- Wear body protection made from durable, flame-resistant material (leather, heavy cotton, wool). Body protection includes oil-free clothing such as leather gloves, heavy shirt, cuffless trousers, high shoes, and a cap.

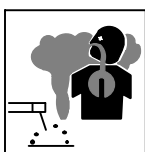

### FUMES AND GASES can be hazardous.

- Keep your head out of the fumes.
- Ventilate area, or use breathing device. The recommended way to determine adequate ventilation is to sample for the composition and quantity of fumes and gases to which personnel are exposed.
- Read and understand the Safety Data Sheets (SDSs) and the manufacturer's instructions for adhesives, coatings, cleaners, consumables, coolants, degreasers, fluxes, and metals.



### BUILDUP OF GAS can injure or kill.

- Shut off compressed gas supply when not in use.
- Always ventilate confined spaces or use approved air-supplied respirator.



### WELDING can cause fire or explosion.

- Do not weld near flammable material.
- Do not weld on containers that have held combustibles, or on closed containers such as tanks, drums, or pipes unless they are properly prepared according to AWS F4.1 and AWS A6.0 (see Safety Standards).
- Watch for fire; keep extinguisher nearby.
- Read and understand the Safety Data Sheets (SDSs) and the manufacturer's instructions for adhesives, coatings, cleaners, consumables, coolants, degreasers, fluxes, and metals.



### HOT PARTS can burn.

- Allow torch to cool before touching.
- Do not touch hot metal.
- Protect hot metal from contact by others.

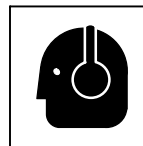

### NOISE can damage hearing.

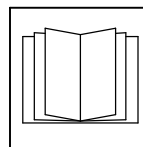

- Check for noise level limits exceeding those specified by OSHA.
- Use approved ear plugs or ear muffs if noise level is high.
- Warn others nearby about noise hazard.



### READ INSTRUCTIONS.

- Read and follow all labels and the Owner's Manual carefully before installing, operating, or servicing unit. Read the safety information at the beginning of the manual and in each section.
- Use only genuine replacement parts from the manufacturer.
- Perform installation, maintenance, and service according to the Owner's Manuals, industry standards, and national, state, and local codes.

## 1-3. Proposition 65 Warnings

-  Welding or cutting equipment produces fumes or gases which contain chemicals known to the State of California to cause birth defects and, in some cases, cancer. (California Health & Safety Code Section 25249.5 et seq.)
-  This product contains chemicals, including lead, known to the state of California to cause cancer, birth defects, or other reproductive harm. *Wash hands after use.*

-  This product contains or produces a chemical known to the State of California to cause cancer or birth defects (or other reproductive harm). (California Health & Safety Code Section 25249.5 et seq.)

## 1-4. Principal Safety Standards

*Safety in Welding, Cutting, and Allied Processes*, ANSI Standard Z49.1, is available as a free download from the American Welding Society at <http://www.aws.org> or purchased from Global Engineering Documents (phone: 1-877-413-5184, website: [www.global.ihs.com](http://www.global.ihs.com)).

*Safe Practice For Occupational And Educational Eye And Face Protection*, ANSI Standard Z87.1, from American National Standards Institute, 25 West 43rd Street, New York, NY 10036 (phone: 212-642-4900, website: [www.ansi.org](http://www.ansi.org)).

*Safe Practices for the Preparation of Containers and Piping for Welding and Cutting*, American Welding Society Standard AWS F4.1, from Global Engineering Documents (phone: 1-877-413-5184, website: [www.global.ihs.com](http://www.global.ihs.com)).

*Safe Practices for Welding and Cutting Containers that have Held Combustibles*, American Welding Society Standard AWS A6.0, from Global Engineering Documents (phone: 1-877-413-5184, website: [www.global.ihs.com](http://www.global.ihs.com)).

*National Electrical Code*, NFPA Standard 70, from National Fire Protection Association, Quincy, MA 02269 (phone: 1-800-344-3555, website: [www.nfpa.org](http://www.nfpa.org) and [www.sparky.org](http://www.sparky.org)).

*Safe Handling of Compressed Gases in Cylinders*, CGA Pamphlet P-1, from Compressed Gas Association, 14501 George Carter Way, Suite 103, Chantilly, VA 20151 (phone: 703-788-2700, website: [www.cganet.com](http://www.cganet.com)).

*Safety in Welding, Cutting, and Allied Processes*, CSA Standard W117.2, from Canadian Standards Association, Standards Sales, 5060 Spectrum Way, Suite 100, Mississauga, Ontario, Canada L4W 5N5 (phone: 800-463-6727, website: [www.csagroup.org](http://www.csagroup.org)).

*Safe Practice For Occupational And Educational Eye And Face Protection*, ANSI Standard Z87.1, from American National Standards Institute, 25 West 43rd Street, New York, NY 10036 (phone: 212-642-4900, website: [www.ansi.org](http://www.ansi.org)).

*Standard for Fire Prevention During Welding, Cutting, and Other Hot Work*, NFPA Standard 51B, from National Fire Protection Association, Quincy, MA 02269 (phone: 1-800-344-3555, website: [www.nfpa.org](http://www.nfpa.org)).

OSHA, Occupational Safety and Health Standards for General Industry, Title 29, Code of Federal Regulations (CFR), Part 1910, Subpart Q, and Part 1926, Subpart J, from U.S. Government Printing Office, Superintendent of Documents, P.O. Box 371954, Pittsburgh, PA 15250-7954 (phone: 1-866-512-1800) (there are 10 OSHA Regional Offices—phone for Region 5, Chicago, is 312-353-2220, website: [www.osha.gov](http://www.osha.gov)).

## 1-5. EMF Information

Electric current flowing through any conductor causes localized electric and magnetic fields (EMF). The current from arc welding (and allied processes including spot welding, gouging, plasma arc cutting, and induction heating operations) creates an EMF field around the welding circuit. EMF fields can interfere with some medical implants, e.g. pacemakers. Protective measures for persons wearing medical implants have to be taken. For example, restrict access for passers-by or conduct individual risk assessment for welders. All welders should use the following procedures in order to minimize exposure to EMF fields from the welding circuit:

1. Keep cables close together by twisting or taping them, or using a cable cover.
2. Do not place your body between welding cables. Arrange cables to one side and away from the operator.

3. Do not coil or drape cables around your body.
4. Keep head and trunk as far away from the equipment in the welding circuit as possible.
5. Connect work clamp to workpiece as close to the weld as possible.
6. Do not work next to, sit or lean on the welding power source.
7. Do not weld whilst carrying the welding power source or wire feeder.

### About Implanted Medical Devices:

Implanted Medical Device wearers should consult their doctor and the device manufacturer before performing or going near arc welding, spot welding, gouging, plasma arc cutting, or induction heating operations. If cleared by your doctor, then following the above procedures is recommended.

# SECTION 2 – CONSIGNES DE SÉCURITÉ – LIRE AVANT UTILISATION

SR6(TIG)\_2015-09fre

**⚠** Pour écarter les risques de blessure pour vous-même et pour autrui — lire, appliquer et ranger en lieu sûr ces consignes relatives aux précautions de sécurité et au mode opératoire.

## 2-1. Signification des symboles



**DANGER!** – Indique une situation dangereuse qui si on l'évite pas peut donner la mort ou des blessures graves. Les dangers possibles sont montrés par les symboles joints ou sont expliqués dans le texte.



Indique une situation dangereuse qui si on l'évite pas peut donner la mort ou des blessures graves. Les dangers possibles sont montrés par les symboles joints ou sont expliqués dans le texte.

**AVIS** – Indique des déclarations pas en relation avec des blessures personnelles.

 Indique des instructions spécifiques.



Ce groupe de symboles veut dire Avertissement! Attention! DANGER DE CHOC ELECTRIQUE, PIECES EN MOUVEMENT, et PIECES CHAUDES. Consulter les symboles et les instructions ci-dessous y afférant pour les actions nécessaires afin d'éviter le danger.

## 2-2. Dangers relatifs au soudage à l'arc

**⚠** Les symboles présentés ci-après sont utilisés tout au long du présent manuel pour attirer votre attention et identifier les risques de danger. Lorsque vous voyez un symbole, soyez vigilant et suivez les directives mentionnées afin d'éviter tout danger. Les consignes de sécurité présentées ci-après ne font que résumer l'information contenue dans les normes de sécurité énumérées dans le manuel d'utilisation du poste de soudage. Veuillez lire et respecter toutes ces normes de sécurité.

**⚠** L'installation, l'utilisation, l'entretien et les réparations ne doivent être confiés qu'à des personnes qualifiées.

**⚠** Au cours de l'utilisation, tenir toute personne à l'écart et plus particulièrement les enfants.



### UN CHOC ÉLECTRIQUE peut tuer.

- Porter toujours des gants secs et isolants.
- S'isoler de la pièce et de la terre.
- Ne jamais toucher une électrode ou des pièces électriques sous tension.
- Avant de souder, vérifier que la tête de torche est solidement fixée au corps de la torche.
- Ne pas regrouper les flexibles de torche refroidis par eau- et les câbles d'alimentation à l'aide de ruban adhésif ou d'attaches en plastique, cela restreint l'écoulement de l'eau, ce qui peut causer une surchauffe du câble d'alimentation et un éclatement des flexibles de torche.
- Remplacer une torche qui est usée, endommagée ou craquée.
- Mettre la soudeuse hors tension avant de remplacer un électrode de tungstène ou des pièces de torche.
- S'assurer que tous les couvercles et poignées sont fermement assujettis.

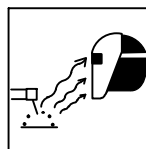

### LES RAYONS DE L'ARC peuvent provoquer des brûlures dans les yeux et sur la peau.

Le rayonnement de l'arc du procédé de soudage génère des rayons visibles et invisibles intenses (ultraviolets et infrarouges) susceptibles de provoquer des brûlures dans les yeux et sur la peau. Des étincelles sont projetées pendant le soudage.

- Porter un casque de soudage approuvé muni de verres filtrants approprié pour protéger visage et yeux pendant le soudage (voir ANSI Z49.1 et Z87.1 énuméré dans les normes de sécurité).
- Porter des lunettes de sécurité avec écrans latéraux même sous votre casque.

- Avoir recours à des écrans protecteurs ou à des rideaux pour protéger les autres contre les rayonnements les éblouissements et les étincelles ; prévenir toute personne sur les lieux de ne pas regarder l'arc.
- Porter un équipement de protection pour le corps fait d'un matériau résistant et ignifuge (cuir, coton robuste, laine). La protection du corps comporte des vêtements sans huile comme par ex. des gants de cuir, une chemise solide, des pantalons sans revers, des chaussures hautes et une casquette.

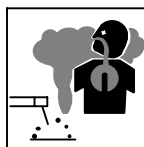

### LES VAPEURS ET LES FUMÉES peuvent être nocives.

- Éloigner sa tête des endroits renfermant des vapeurs.
- Aérer la zone de travail ou porter un appareil respiratoire. Pour déterminer la bonne ventilation, il est recommandé de procéder à un prélèvement pour la composition et la quantité de fumées et de gaz auxquels est exposé le personnel.
- Lire et comprendre les fiches de données de sécurité et les instructions du fabricant concernant les adhésifs, les revêtements, les nettoyeurs, les consommables, les produits de refroidissement, les dégraissateurs, les flux et les métaux.



### L'ACCUMULATION DE VAPEURS peut causer des lésions ou la mort.

- Après utilisation, fermer l'alimentation de gaz sous pression.
- Assurer toujours la ventilation des zones fermées ou utiliser un appareil respiratoire avec alimentation en air.



### LE SOUDAGE peut causer un incendie ou une explosion.

- Ne pas souder à proximité de matériaux inflammables.
- Ne pas effectuer le soudage sur des conteneurs fermés tels que des réservoirs, tambours, ou conduites, à moins qu'ils n'aient été préparés correctement conformément à AWS F4.1 et AWS A6.0 (voir les Normes de Sécurité).
- Prendre garde aux incendies et toujours avoir un extincteur à proximité.
- Lire et comprendre les fiches de données de sécurité et les instructions du fabricant concernant les adhésifs, les revêtements, les nettoyeurs, les consommables, les produits de refroidissement, les dégraissateurs, les flux et les métaux.



### LES PIÈCES CHAUDES peuvent provoquer des brûlures.

- Laisser refroidir la torche avant de le toucher.
- Ne pas toucher d'objets métalliques chauds.
- Abriter les objets métalliques contre tout contact par les personnes à proximité.



### Le BRUIT peut endommager l'ouïe.

- Vérifier si les niveaux de bruit excèdent les limites spécifiées par l'OSHA.
  - Utiliser des bouche-oreilles ou des serre-tête antibruit approuvés si le niveau de bruit est élevé.
- Avertir les personnes à proximité au sujet du danger inhérent au bruit.

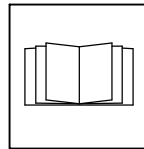

### LIRE LES INSTRUCTIONS.

- Lire et appliquer les instructions sur les étiquettes et le Mode d'emploi avant l'installation, l'utilisation ou l'entretien de l'appareil. Lire les informations de sécurité au début du manuel et dans chaque section.
- N'utiliser que les pièces de rechange recommandées par le constructeur.
- Effectuer l'installation, l'entretien et toute intervention selon les manuels d'utilisateurs, les normes nationales, provinciales et de l'industrie, ainsi que les codes municipaux.

## 2-3. Proposition californienne 65 Avertissements

**⚠ Les équipements de soudage et de coupage produisent des fumées et des gaz qui contiennent des produits chimiques dont l'État de Californie reconnaît qu'ils provoquent des malformations congénitales et, dans certains cas, des cancers. (Code de santé et de sécurité de Californie, chapitre 25249.5 et suivants)**

**⚠ Ce produit contient des éléments chimiques, dont le plomb, reconnus par l'État de Californie pour leur caractère cancé-**

**rogène ainsi que provoquant des malformations congénitales ou autres problèmes de procréation. Se laver les mains après toute manipulation.**

**⚠ Ce produit contient des substances chimiques (dont le plomb) reconnues par l'État de la Californie comme pouvant causer le cancer, des anomalies congénitales ou d'autres préjudices au système reproductif.**

## 2-4. Principales normes de sécurité

*Safety in Welding, Cutting, and Allied Processes*, ANSI Standard Z49.1, is available as a free download from the American Welding Society at <http://www.aws.org> or purchased from Global Engineering Documents (phone: 1-877-413-5184, website: [www.global.ihs.com](http://www.global.ihs.com)).

*Safe Practice For Occupational And Educational Eye And Face Protection*, ANSI Standard Z87.1, from American National Standards Institute, 25 West 43rd Street, New York, NY 10036 (phone: 212-642-4900, website: [www.ansi.org](http://www.ansi.org)).

*Safe Practices for the Preparation of Containers and Piping for Welding and Cutting*, American Welding Society Standard AWS F4.1, from Global Engineering Documents (phone: 1-877-413-5184, website: [www.global.ihs.com](http://www.global.ihs.com)).

*Safe Practices for Welding and Cutting Containers that have Held Combustibles*, American Welding Society Standard AWS A6.0, from Global Engineering Documents (phone: 1-877-413-5184, website: [www.global.ihs.com](http://www.global.ihs.com)).

*National Electrical Code*, NFPA Standard 70, from National Fire Protection Association, Quincy, MA 02269 (phone: 1-800-344-3555, website: [www.nfpa.org](http://www.nfpa.org) and [www.sparky.org](http://www.sparky.org)).

*Safe Handling of Compressed Gases in Cylinders*, CGA Pamphlet P-1, from Compressed Gas Association, 14501 George Carter Way, Suite 103, Chantilly, VA 20151 (phone: 703-788-2700, website: [www.cganet.com](http://www.cganet.com)).

*Safety in Welding, Cutting, and Allied Processes*, CSA Standard W117.2, from Canadian Standards Association, Standards Sales, 5060 Spectrum Way, Suite 100, Mississauga, Ontario, Canada L4W 5N5 (phone: 800-463-6727, website: [www.csagroup.org](http://www.csagroup.org)).

*Safe Practice For Occupational And Educational Eye And Face Protection*, ANSI Standard Z87.1, from American National Standards Institute, 25 West 43rd Street, New York, NY 10036 (phone: 212-642-4900, website: [www.ansi.org](http://www.ansi.org)).

*Standard for Fire Prevention During Welding, Cutting, and Other Hot Work*, NFPA Standard 51B, from National Fire Protection Association, Quincy, MA 02269 (phone: 1-800-344-3555, website: [www.nfpa.org](http://www.nfpa.org)).

OSHA, Occupational Safety and Health Standards for General Industry, Title 29, Code of Federal Regulations (CFR), Part 1910, Subpart Q, and Part 1926, Subpart J, from U.S. Government Printing Office, Superintendent of Documents, P.O. Box 371954, Pittsburgh, PA 15250-7954 (phone: 1-866-512-1800) (there are 10 OSHA Regional Offices—phone for Region 5, Chicago, is 312-353-2220, website: [www.osha.gov](http://www.osha.gov)).

## 2-5. Informations relatives aux CEM

Le courant électrique qui traverse tout conducteur génère des champs électromagnétiques (CEM) à certains endroits. Le courant issu d'un soudage à l'arc (et de procédés connexes, y compris le soudage par points, le gougeage, le découpage plasma et les opérations de chauffage par induction) crée un champ électromagnétique (CEM) autour du circuit de soudage. Les champs électromagnétiques produits peuvent causer interférence à certains implants médicaux, p. ex. les stimulateurs cardiaques. Des mesures de protection pour les porteurs d'implants médicaux doivent être prises: Limiter par exemple tout accès aux passants ou procéder à une évaluation des risques individuels pour les soudeurs. Tous les soudeurs doivent appliquer les procédures suivantes pour minimiser l'exposition aux CEM provenant du circuit de soudage:

- 1 Rassembler les câbles en les torsadant ou en les attachant avec du ruban adhésif ou avec une housse.
- 2 Ne pas se tenir au milieu des câbles de soudage. Disposer les câbles d'un côté et à distance de l'opérateur.

- 3 Ne pas courber et ne pas entourer les câbles autour de votre corps.
- 4 Maintenir la tête et le torse aussi loin que possible du matériel du circuit de soudage.
- 5 Connecter la pince sur la pièce aussi près que possible de la soudure.
- 6 Ne pas travailler à proximité d'une source de soudage, ni s'asseoir ou se pencher dessus.
- 7 Ne pas souder tout en portant la source de soudage ou le dévidoir.

### En ce qui concerne les implants médicaux :

Les porteurs d'implants doivent d'abord consulter leur médecin avant de s'approcher des opérations de soudage à l'arc, de soudage par points, de gougeage, du coupage plasma ou de chauffage par induction. Si le médecin approuve, il est recommandé de suivre les procédures précédentes.







# SECTION 3 – SPECIFICATIONS

## 3-1. Specifications

Model		
	W-350 (WP-18)	W-350V (WP-18V)
<b>Amperage Rating</b>	350 Amps W/Argon Gas At 100% Duty Cycle DCEN; 250 Amps W/Argon Gas At 100% duty Cycle ACHF	
<b>Cooling Method</b>	Liquid Cooled	
<b>Cooling Requirements</b>	1.7 L/min (1.8 qt/min or .45 gal/min)	
<b>Tungsten Size</b>	.020 Thru 5/32 in. (0.5 Thru 4.0 mm)	
<b>Cable Options</b>	12.5 ft (3.8 m) Or 25 ft (7.6 m) Three-Piece Rubber 12.5 ft (3.8 m) Or 25 ft (7.6 m) Three-Piece Vinyl	
<b>Dimensions</b>	Length: 8 in. (203 mm); Handle Diameter: 1.13 in. (29 mm) Weight: 8.55 oz (242 g)	Length: 8.5 in. (216 mm); Handle Diameter: 1.13 in. (29 mm) Weight: 9.5 oz (269 g)

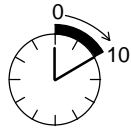
## 3-2. Duty Cycle

 	<p style="text-align: center;"><b>Definition</b></p> <p>Duty Cycle is percentage of 10 minutes that torch can weld at rated load without overheating.</p>	<p style="text-align: center;"><b>100% Duty Cycle At 350 Amperes Using Argon Gas w/DCEN</b></p> <p style="text-align: center;"><b>100% Duty Cycle At 500 Amperes Using Argon Gas w/DCEN For WP-18P</b></p> <div style="display: flex; justify-content: space-around; align-items: center;"> <div style="text-align: center;">  <p>Minutes</p> </div> <div style="text-align: center;">  <p>Continuous Welding</p> </div> </div> <p style="text-align: right; font-size: small;">sb1.5* 8/93</p>
<p><b>NOTICE</b> – EXCEEDING RATED AMPERAGE can damage torch and void warranty.</p> <ul style="list-style-type: none"> <li>• Do not exceed rated amperage (see Section 3-1)</li> </ul>		

# SECTION 4 – INSTALLATION

## 4-1. Required Torch Parts And Torch Assembly

WC0217-B

<p>1 Cup</p> <p>2 Collet Body</p> <p>3 Collet</p> <p>4 Backcap (Includes O-Ring)</p> <p>5 Torch Body</p> <p>6 Handle</p> <p>7 Water Hose</p> <p>8 Gas Hose</p> <p>9 Power Cable</p> <p>10 Power Cable Adapter</p> <p>11 International Style Adapter</p>	<p>12 Water Hose For International Style Adapter</p> <p>13 Tungsten Tungsten Electrode (See Section 6)</p> <p><b>Assembling Torch</b></p> <p>Assemble torch as follows:</p> <ul style="list-style-type: none"> <li>• Thread collet body into front of torch body (head), and finger tighten</li> <li>• Thread nozzle onto collet body, and finger tighten.</li> <li>• Slide collet over unpainted end of tungsten.</li> <li>• Insert collet/tungsten assembly through back of torch body (head).</li> </ul>	<ul style="list-style-type: none"> <li>• Pull tungsten out of collect body to obtain desired stick out length.</li> <li>• Thread backcap into back of torch body (head), and tighten to clamp and secure tungsten.</li> </ul> <p><b>Installing Tungsten</b></p> <p>Adjust tungsten stick out as follows:</p> <ul style="list-style-type: none"> <li>• Loosen backcap enough to allow tungsten to slide freely in collet.</li> </ul> <p><i>It is not necessary to remove backcap.</i></p> <ul style="list-style-type: none"> <li>• Pull tungsten out end of collet body far enough to obtain desired stick out.</li> <li>• Tighten backcap to secure tungsten.</li> </ul>
---	---	--

## 4-2. International Style Connector Assembly

1 Weld Output Cable

2 Insulating Boot

3 Sleeve

4 Connector Body

5 Setscrew

Slide insulating boot onto cable; strip cable and install sleeve.

Insert cable with sleeve fully into connector body, tighten setscrew, and slide insulating boot over connector.

Tools Needed:

ST-156 496

## 4-3. Connecting Torch

### A. Connecting Torch To A PipeWorx With A PipeWorx Cooler

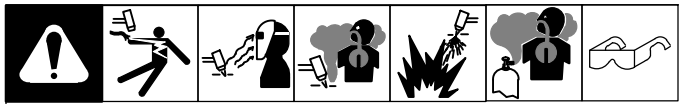

If applicable, install high-frequency unit.

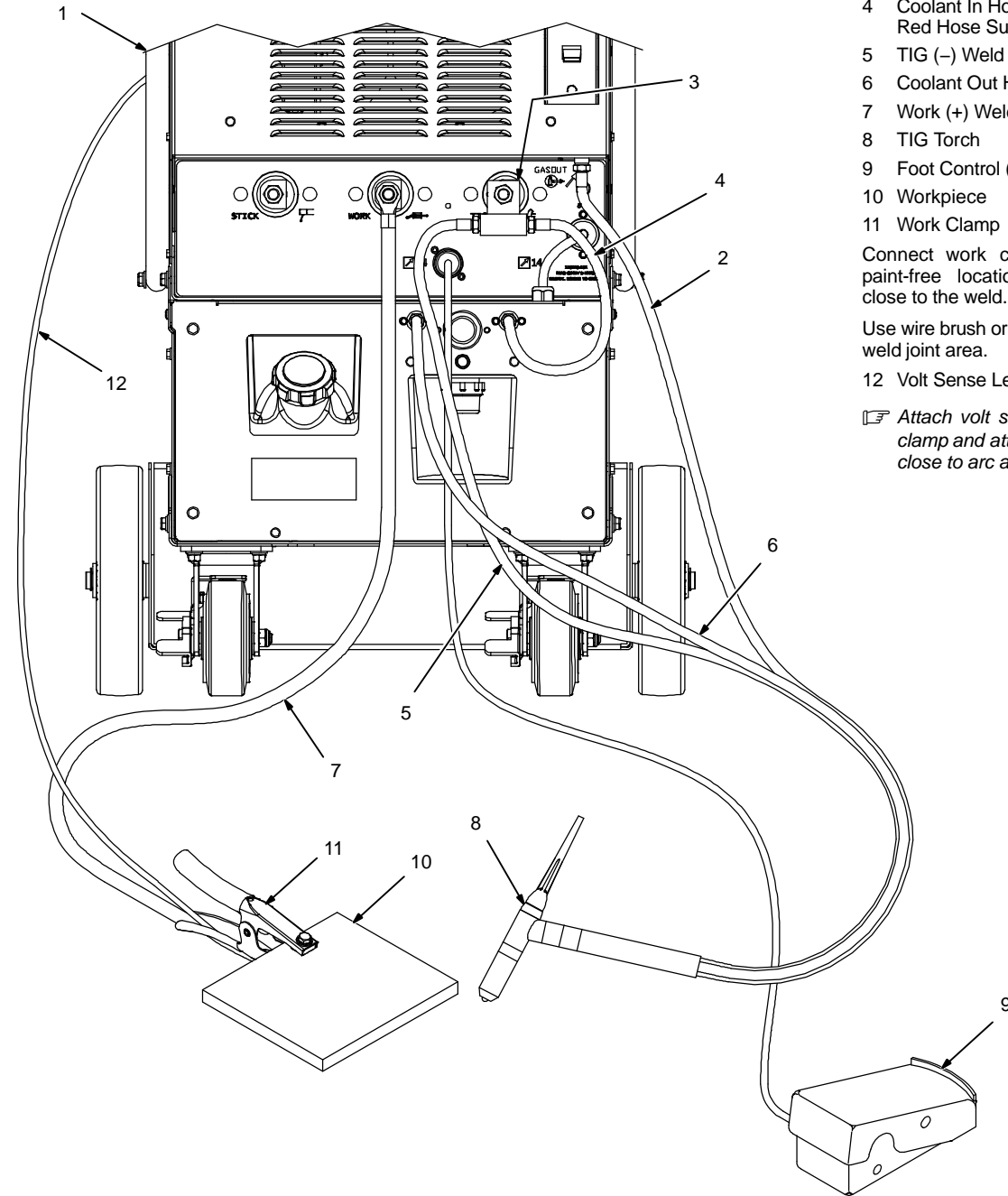

**Turn Off welding power source power before installing torch..**

- 1 Welding Power Source
- 2 Gas Hose
- 3 TIG Block (Customer Supplied)
- 4 Coolant In Hose 237 416 (Short Red Hose Supplied With Cooler)
- 5 TIG (-) Weld Cable/Coolant In
- 6 Coolant Out Hose
- 7 Work (+) Weld Cable
- 8 TIG Torch
- 9 Foot Control (Optional)
- 10 Workpiece
- 11 Work Clamp

Connect work clamp to a clean, paint-free location on workpiece, close to the weld.

Use wire brush or sandpaper to clean weld joint area.

12 Volt Sense Lead

Attach volt sense lead to work clamp and attach work clamp as close to arc as possible.

Tools Needed:



11/16 in.

## B. Connecting Torch To A Dynasty™ 350 TIGRunner™



**⚠ Turn Off welding power source power before installing torch..**

- 1 Gas Hose With 5/8-18 Right-Hand Fittings (Customer Supplied)

### Connections:

- 2 Regulator/Flowmeter
- 3 Gas Cylinder
- 4 Coolant System
- 5 Electrode Weld Output Terminal

Connect TIG torch to electrode weld output terminal.

- 6 Gas Out Connection

Connect TIG torch gas hose to gas out fitting.

- 7 Work Weld Output Terminal

- 8 Work Lead (Clamp)

Connect work lead to work weld output terminal.

- 9 Coolant-Into Torch Hose (Blue)

Connect torch coolant-in (blue) hose to coolant system coolant-out connection.

- 10 Coolant-Out Of Torch Power Cable (Red)

Connect torch coolant-out (red) hose to coolant system coolant-in connection.

- 11 Welding Power Source

- 12 Foot Control

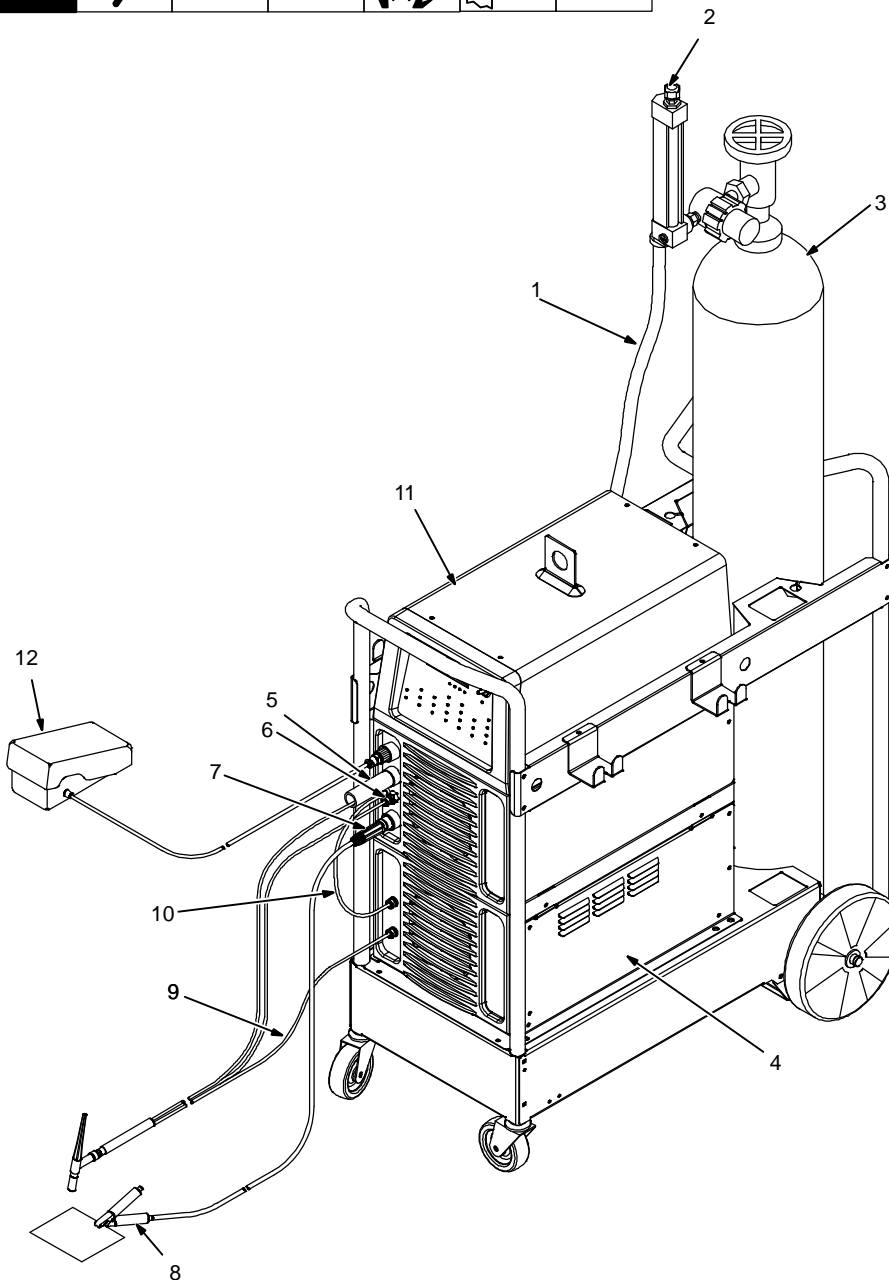

### Tools Needed:



 11/16 in.

### C. Connecting Torch To A Syncrowave® 250 DX Or 350 LX TIGRunner Unit



**⚠ Turn Off welding power source power before installing torch.**

- 1 Gas Hose With 5/8-18 Right-Hand Fittings (Customer Supplied)

**Connections:**

- 2 Gas Cylinder
- 3 Regulator/Flowmeter
- 4 Power Source
- 5 Coolant System
- 6 Torch
- 7 Coolant-Into Torch Hose (Blue)
- 8 Coolant-Out Of Torch/Power Cable (Red)

Connect torch coolant-out of torch/power cable to power cable adapter, and connect adapter to weld output terminal.

- 9 Torch Gas Hose

- 10 Work Clamp

Connect work clamp to a clean, paint-free location on workpiece, close to the weld.

Use wire brush or sandpaper to clean weld joint area.

- 11 Foot Control

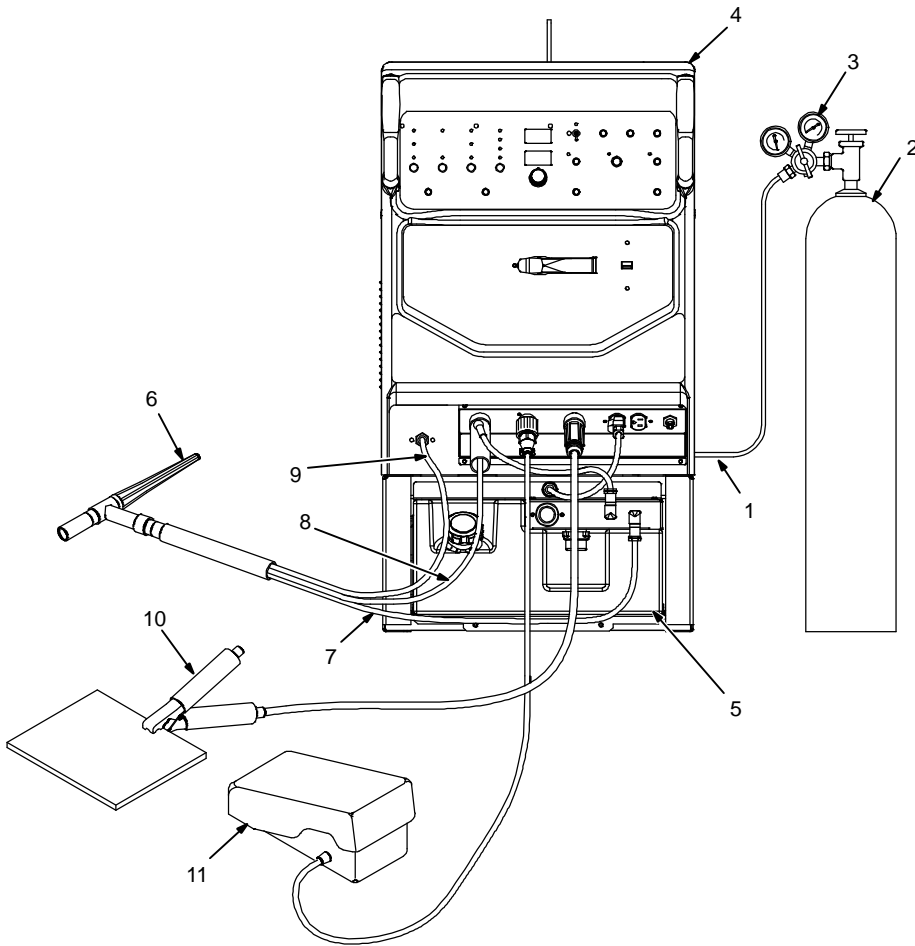







**Tools Needed:**









 11/16 in.

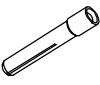

# SECTION 5 – MAINTENANCE & TROUBLESHOOTING

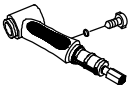
## 5-1. Routine Maintenance

							<b>▲ Disconnect torch before maintaining.</b>
---	---	---	---	---	---	---	---

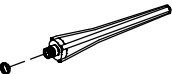
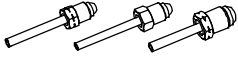
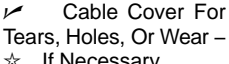
	✓ = Check      ◇ = Change      ● = Clean      ☆ = Replace * To be done by Factory Authorized Service Agent						
Daily	 ✓ Nozzle For Cracks – ☆ If Necessary			 ✓ Check Tungsten Preparation (See Section 6)			
Weekly	 ✓ Collet For Wear – ☆ If Necessary	 ✓ Collet Body Threads – ☆ If Necessary	 ✓ Gas Lens Screen – ☆ If Necessary	 ✓ Gas Valve, If Applicable – ☆ If Necessary			
Monthly	 ✓ Power Cable For Cracks, Wear – ☆ If Necessary	 ✓ Gas Hose For Cracks, Leaks, Wear – ☆ If Necessary	 ✓ Water Hose, If Applicable, For Cracks, Leaks, Wear – ☆ If Necessary	 ✓ Back Cap O-Ring – ☆ If Necessary			
	 ✓ Power, Gas, And Water Cable Connections To En- sure They Are Tight		 ✓ Cable Cover For Tears, Holes, Or Wear – ☆ If Necessary				
* When using a water-cooled torch, maintain cooling equipment according to the manufactures recommendations.							

## 5-2. Troubleshooting

☞ Before using troubleshooting table, check selection and preparation of tungsten electrode according to Section 6.



Trouble	Remedy
Arc will not start. High frequency present and visible at the torch.	Check cable and work connections. Be sure weld circuit is complete (see Section 4-3). Check and be sure shielding gas is present.
Lack of high frequency; difficulty in establishing arc.	Select proper size and type tungsten. Properly prepare tungsten according to Section 6. Check cables and torch for cracks or bad connections. Be sure that torch cables are not close to any grounded metal. Repair or replace necessary parts. Check torch consumables. Be sure collet and collet body are correctly installed and tightened (see Section 4-1). Check welding power source High Frequency control, and if necessary, check and adjust spark gaps.
Torch gas valve not working properly (if applicable).	Have Factory Authorized Service Station/Service Distributor check valve.
No shielding gas flow from torch.	Be sure valves on gas supply are open. Check cable for kinks, blockage, or leaks. Check and tighten all gas supply fittings. Tighten collet body or gas lens before tightening backcap.
No shielding gas flow from torch.	Check cables and torch for cracked insulation or bad connections. Repair or replace (see Section 5-1).
Tungsten electrode oxidizing and not remaining bright after conclusion of weld.	Shield weld zone from drafts. Increase postflow time. Increase gas flow rate. Check manufacture's recommendations. Check and tighten all gas fittings. Check gas valve and flow meter/regulator. Select proper size and type tungsten. Properly prepare tungsten (see Section 6).
Excessive tungsten electrode consumption.	Select proper size and type tungsten. Properly prepare tungsten according to Section 6. Check polarity setting on welding power source (see welding power source Owner's manual). Check for proper gas flow rate. Check manufacture's recommendations. If torch is water cooled, check torch and cables for water leaks. Repair or replace if necessary (see Section 5-1).





# SECTION 6 – SELECTING AND PREPARING A TUNGSTEN FOR DC OR AC WELDING

gtaw\_Phase\_2011-06

Whenever possible and practical, use DC weld output instead of AC weld output.

## 6-1. Selecting Tungsten Electrode (Wear Clean Gloves To Prevent Contamination Of Tungsten)



☞ Not all tungsten electrode manufacturers use the same colors to identify tungsten type. Contact the tungsten electrode manufacturer or reference the product packaging to identify the tungsten you are using.

Electrode Diameter	Amperage Range - Gas Type ♦ - Polarity	
	(DCEN) – Argon Direct Current Electrode Negative (For Use With Mild Or Stainless Steel)	AC – Argon Balance Control @ 65% Electrode Negative (For Use With Aluminum)
<b>2% Ceria, 1.5% Lanthanum, Or 2% Thorium Alloy Tungstens</b>		
.040" (1 mm)	25-85	20-80
1/16" (1.6 mm)	50-160	50-150
3/32" (2.4 mm)	130-250	135-235
1/8" (3.2 mm)	250-400	225-360
<b>Pure Tungsten</b>		
.040" (1 mm)	Pure Tungsten Not Recommended For DCEN – Argon	10-60
1/16" (1.6 mm)		50-100
3/32" (2.4 mm)		100-160
1/8" (3.2 mm)		150-210

♦ Typical argon shielding gas flow rates are 11 to 35 cfh (cubic feet per hour).

Figures listed are a guide and are a composite of recommendations from American Welding Society (AWS) and electrode manufacturers.

## 6-2. Preparing Tungsten Electrode For Welding With Phase Control Machines

Grinding the tungsten electrode produces dust and flying sparks which can cause injury and start fires. Use local exhaust (forced ventilation) at the grinder or wear an approved respirator. Read MSDS for safety information. Consider using tungsten containing ceria, lanthana, or yttria instead of thoria. Grinding dust from thoriated electrodes contains low-level radioactive material. Properly dispose of grinder dust in an environmentally safe way. Wear proper face, hand, and body protection. Keep flammables away.

### A. Preparing Tungsten For DC Electrode Negative (DCEN) Welding

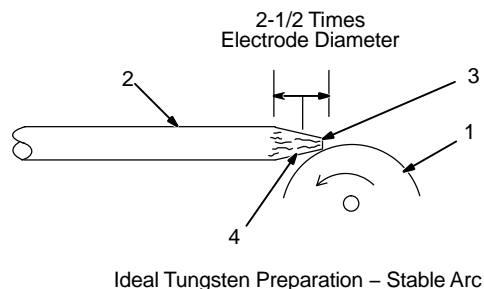
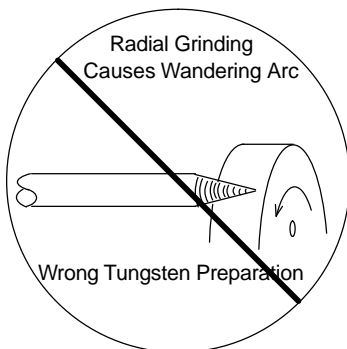

#### 1 Grinding Wheel

Grind end of tungsten on fine grit, hard abrasive wheel before welding. Do not use wheel for other jobs or tungsten can become contaminated causing lower weld quality.

#### 2 Tungsten Electrode

A 2% ceriated tungsten is recommended.

#### 3 Flat

Diameter of this flat determines amperage capacity.

#### 4 Straight Ground

Grind lengthwise, **not radial**.

### B. Preparing Tungsten For AC Welding

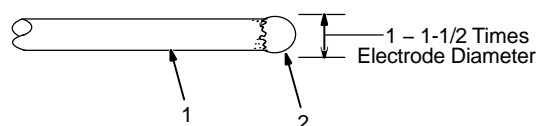

#### 1 Tungsten Electrode

A pure tungsten is recommended..

#### 2 Balled End

Ball end of tungsten by applying AC amperage recommended for a given electrode diameter (see Section 6-1). Let ball on end of the tungsten take its own shape.

# SECTION 7 – GUIDELINES FOR TIG WELDING (GTAW)

2007-04

## 7-1. Positioning The Torch

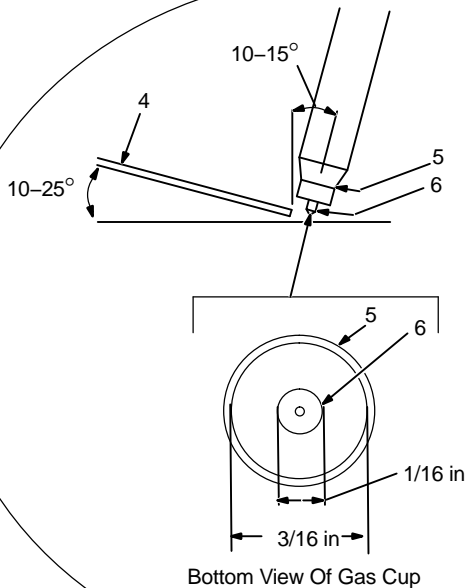
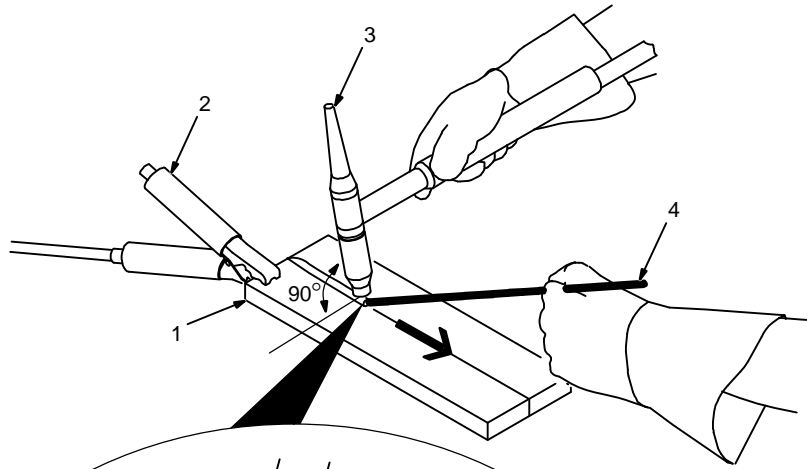

**⚠** Grinding the tungsten electrode produces dust and flying sparks which can cause injury and start fires. Use local exhaust (forced ventilation) at the grinder or wear an approved respirator. Read MSDS for safety information. Consider using cerium or lanthanum based tungsten instead of thoriated. Thorium dust contains low-level radioactive material. Properly dispose of grinder dust in an environmentally safe way. Wear proper face, hand, and body protection. Keep flammables away.

1 Workpiece

Make sure workpiece is clean before welding.

2 Work Clamp

Place as close to the weld as possible.

3 Torch

4 Filler Rod (If Applicable)

5 Gas Cup

6 Tungsten Electrode

Select and prepare tungsten according to Section 6.

### Guidelines:

The inside diameter of the gas cup should be at least three times the tungsten diameter to provide adequate shielding gas coverage. (For example, if tungsten is 1/16 in diameter, gas cup should be a minimum of 3/16 in diameter.)

Tungsten extension is the distance the tungsten extends out gas cup of torch.

The tungsten extension should be no greater than the inside diameter of the gas cup.

Arc length is the distance from the tungsten to the workpiece.

Ref. ST-161 892

## 7-2. Torch Movement During Welding

### Tungsten Without Filler Rod

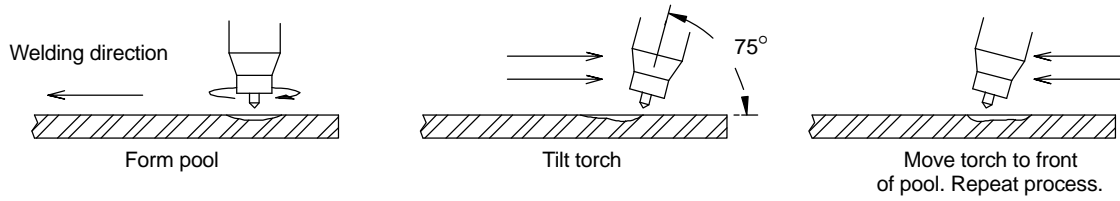

### Tungsten With Filler Rod

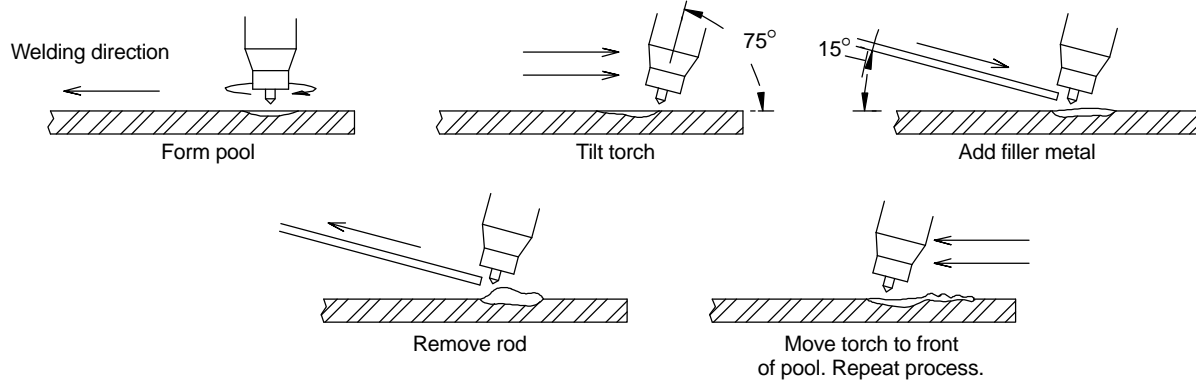

ST-162 002-B

## 7-3. Positioning Torch Tungsten For Various Weld Joints

### Butt Weld And Stringer Bead

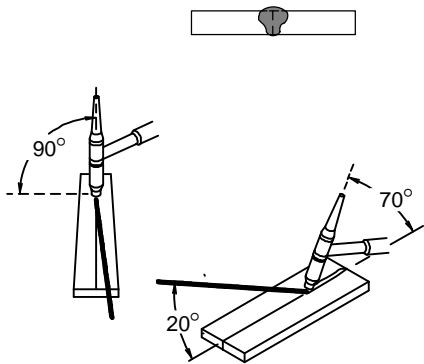

### "T" Joint

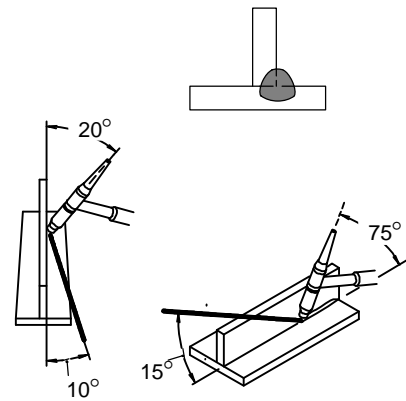

### Lap Joint

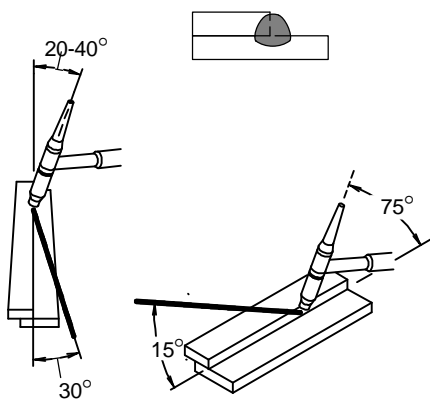

### Corner Joint

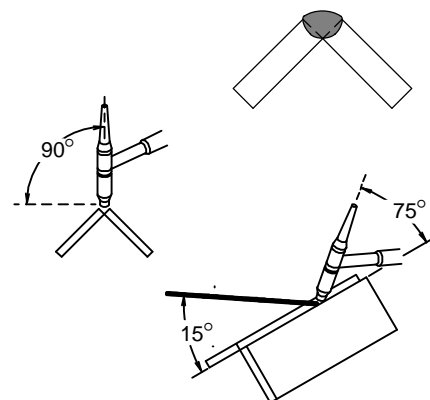

ST-162 003 / S-0792

# SECTION 8 – PARTS LIST

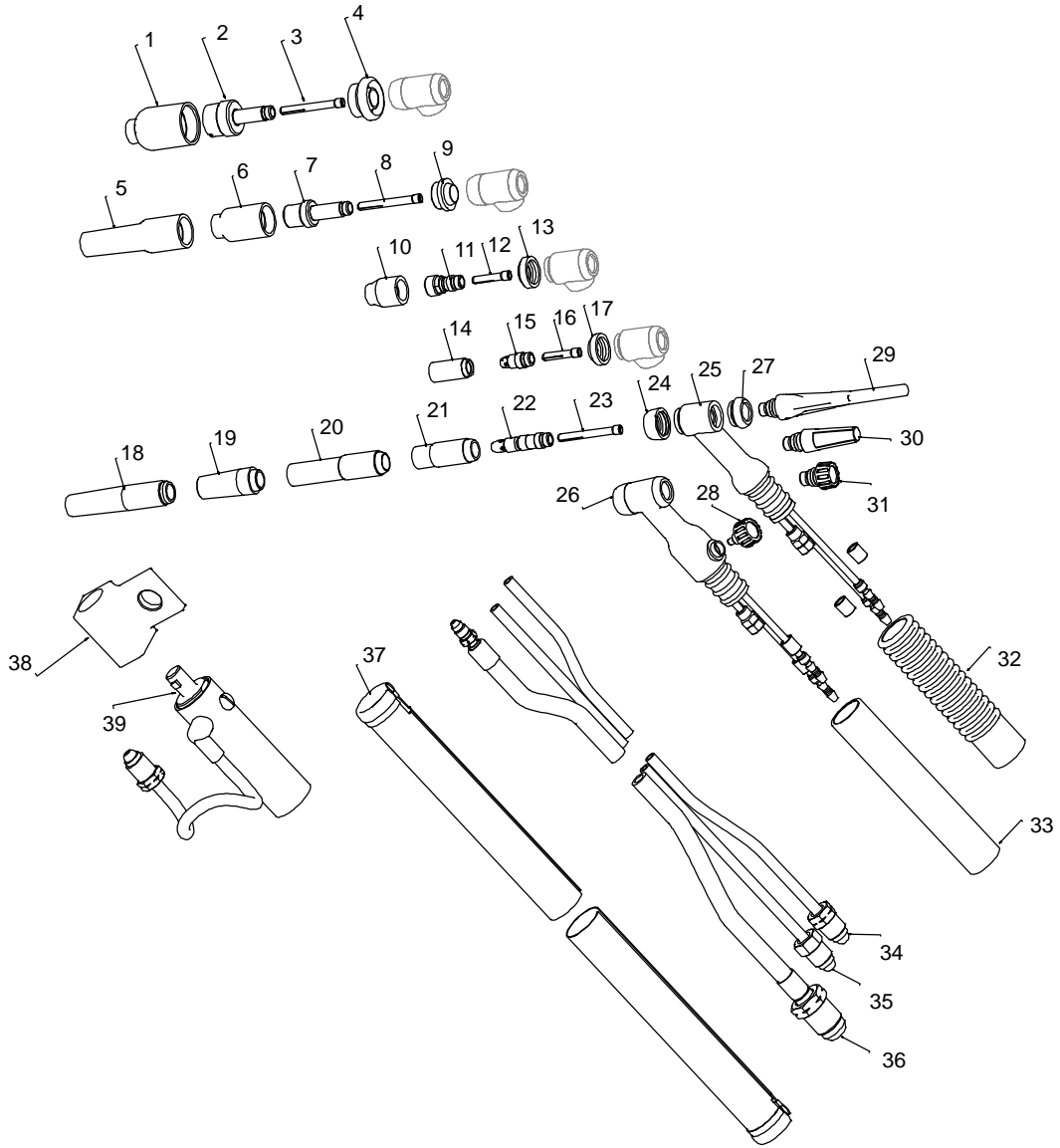

WC0218-B

Figure 8-1. Complete Torch Assembly

Item No.	Part No.	Description	Quantity	
			W-350 (WP-18)	W-350V (WP-18V)

**Figure 8-1. Complete Torch Assembly**

... 1	◆57N75	.. Nozzle, Alumina GL LG #6 (3/8 in.)	1	1
... 1	◆57N74	.. Nozzle, Alumina GL LG #8 (1/2 in.)	1	1
... 1	◆53N88	.. Nozzle, Alumina GL LG #10 (5/8 in.)	1	1
... 1	◆53N87	.. Nozzle, Alumina GL LG #12 (3/4 in.)	1	1
... 1	◆53N89	.. Nozzle, Alumina GL LG Short #15 (15/16 in.)	1	1
... 2	◆45V0204	.. Gas Lens, Large 0.020–0.040 in. (0.5–1.0 mm)	1	1
... 2	◆45V116	.. Gas Lens, Large 1/16 in. (1.6 mm)	1	1
... 2	◆45V64	.. Gas Lens, Large 3/32 in. (2.4 mm)	1	1
... 2	◆995795	.. Gas Lens, Large 1/8 in. (3.2)	1	1
... 2	◆45V63	.. Gas Lens, Large 1/16 in. (1.6 mm)	1	1
... 3	◆10N21	.. Collet, 0.020 in. (0.5 mm)	1	1
... 3	◆10N22	.. Collet, 0.040 in. (1.0 mm)	1	1
... 3	◆10N23	.. Collet, 1/16 in. (1.6 mm)	1	1
... 3	◆10N24	.. Collet, 3/32 in.(2.4 mm)	1	1
... 3	◆10N25	.. Collet, 1/8 in. (3.2 mm)	1	1
... 3	◆54N20	.. Collet, 5/32 in. (4.0 mm)	1	1
... 4	◆54N63	.. Insulator, Gas lens LG	1	1
... 5	◆54N17L	.. Nozzle, Alumina GL Long #5 (5/16 in.)	1	1
... 5	◆54N16L	.. Nozzle, Alumina GL Long #6 (3/8 in.)	1	1
... 5	◆54N15L	.. Nozzle, Alumina GL Long #7 (7/16 in.)	1	1
... 6	◆54N18	.. Nozzle, Alumina GL #4 (1/4 in.)	1	1
... 6	◆54N17	.. Nozzle, Alumina GL #5 (5/16 in.)	1	1
... 6	◆54N16	.. Nozzle, Alumina GL #6 (3/8 in.)	1	1
... 6	◆54N15	.. Nozzle, Alumina GL #7 (7/16 in.)	1	1
... 6	◆54N14	.. Nozzle, Alumina GL #8 (1/2 in.)	1	1
... 6	◆54N19	.. Nozzle, Alumina GL Short #11 (11/16 in.)	1	1
... 7	◆45V29	.. Gas Lens 0.020 in. (0.5 mm)	1	1
... 7	◆45V24	.. Gas Lens 0.040 in. (1.0 mm)	1	1
... 7	◆45V25	.. Gas Lens 1/16 in. (1.6 mm)	1	1
... 7	◆45V26	.. Gas Lens 3/32 in. (2.4 mm)	1	1
... 7	◆45V27	.. Gas Lens 1/8 in. (3.2 mm)	1	1
... 7	◆45V28	.. Gas Lens 5/32 in. (4.0 mm)	1	1
... 8	◆10N21	.. Collet 0.020 in (0.5 mm)	1	1
... 8	◆10N22	.. Collet 0.040 in (1.0 mm)	1	1
... 8	◆10N23	.. Collet 1/16 in (1.6 mm)	1	1
... 8	◆10N24	.. Collet 3/32 in (2.4 mm)	1	1
... 8	◆10N25	.. Collet 1/8 in (3.2 mm)	1	1
... 8	◆54N20	.. Collet 5/32 in (4.0 mm)	1	1
... 9	◆54N01	.. Insulator, Gas Lens	1	1
... 10	◆53N58	.. Nozzle, Alumina GL #4 (1/4 in.)	1	1
... 10	◆53N59	.. Nozzle, Alumina GL #5 (5/16 in.)	1	1
... 10	◆53N60	.. Nozzle, Alumina GL #6 (3/8 in.)	1	1
... 10	◆53N61	.. Nozzle, Alumina GL #7 (7/16 in.)	1	1
... 10	◆53N61S	.. Nozzle, Alumina GL #8 (1/2 in.)	1	1
... 11	◆17GL040	.. Gas Lens, Stubby 0.040 in. (1.0 mm)	1	1
... 11	◆17GL116	.. Gas Lens, Stubby 1/16 in. (1.6 mm)	1	1
... 11	◆17GL332	.. Gas Lens, Stubby 3/32 in. (2.4 mm)	1	1
... 11	◆17GL18	.. Gas Lens, Stubby 1/8 in. (3.2 mm)	1	1
... 12	◆10N22S	.. Collet, Stubby 0.040 in. (1.0 mm)	1	1
... 12	◆10N23S	.. Collet, Stubby 1/16 in. (1.6 mm)	1	1
... 12	◆10N24S	.. Collet, Stubby 3/32 in. (2.4 mm)	1	1
... 12	◆10N25S	.. Collet, Stubby 1/8 in. (3.2 mm)	1	1
... 13	◆17GLG20	.. Insulator Gas Lens Stubby	1	1

Item No.	Dia. Mkgs.	Part No.	Description	Quantity	
				W-350 (WP-18)	W-350V (WP-18V)

**Figure 8-1. Complete Torch Assembly (continued)**

14	◆13N08	Nozzle, Alumina #4 (1/4 in.)	1	1
14	◆13N09	Nozzle, Alumina #5 (5/16 in.)	1	1
14	◆13N10	Nozzle, Alumina #6 (3/8 in.)	1	1
14	◆13N11	Nozzle, Alumina #7 (7/16 in.)	1	1
14	◆13N12	Nozzle, Alumina #8 (1/2 in.)	1	1
14	◆13N13	Nozzle, Alumina #10 (5/8 in.)	1	1
15	◆17CB20	Collet Body, Stubby 0.040–1/8 in.(1.0–3.3 mm)	1	1
16	◆10N22S	Collet, Stubby 0.040 in. (1.0 mm)	1	1
16	◆10N23S	Collet, Stubby 1/16 in. (1.6 mm)	1	1
16	◆10N24S	Collet, Stubby 3/32 in. (2.4 mm)	1	1
16	◆10N25S	Collet, Stubby 1/8 in. (3.2 mm)	1	1
17	◆18CG20	Insulator, Nozzle Stubby	1	1
18	◆12N03	Nozzle, Lava Long #4L (1/4 in.)	1	1
18	◆105Z60	Nozzle, Lava Long #5L (5/16 in.)	1	1
18	◆12N02	Nozzle, Lava Long #6L (3/8 in.)	1	1
18	◆105Z61	Nozzle, Lava Long #7L (7/16 in.)	1	1
19	◆105Z43	Nozzle, Lava #4 (1/4 in.)	1	1
19	◆105Z42	Nozzle, Lava #5 (5/16 in.)	1	1
19	◆105Z44	Nozzle, Lava #6 (3/8 in.)	1	1
19	◆105Z45	Nozzle, Lava #7 (7/16 in.)	1	1
19	◆08N78	Nozzle, Lava #8 (1/2 in.)	1	1
19	◆08N79	Nozzle, Lava #10 (5/8 in.)	1	1
19	◆08N80	Nozzle, Lava #12 (3/4 in.)	1	1
20	◆10N49L	Nozzle Alumina Long #5L (5/16 in.)	1	1
20	◆10N48L	Nozzle Alumina Long #6L (3/8 in.)	1	1
20	◆10N47L	Nozzle Alumina Long #7L (7/16 in.)	1	1
21	◆10N50	Nozzle, Alumina #4 (1/4 in.)	1	1
21	◆10N49	Nozzle, Alumina #5 (5/16 in.)	1	1
21	◆10N48	Nozzle, Alumina #6 (3/8 in.)	1	1
21	◆10N47	Nozzle, Alumina #7 (7/16 in.)	1	1
21	◆10N46	Nozzle, Alumina #8 (1/2 in.)	1	1
21	◆10N45	Nozzle, Alumina #10 (5/8 in.)	1	1
21	◆10N44	Nozzle, Alumina #12 (3/4 in.)	1	1
22	◆10N29	Collet Body, 0.020 in. (0.5 mm)	1	1
22	◆10N30	Collet Body, 0.040 in. (1.0 mm)	1	1
22	◆10N31	Collet Body, 1/16 in. (1.6 mm)	1	1
22	◆10N32	Collet Body, 3/32 in. (2.4 mm)	1	1
22	◆10N28	Collet Body, 1/8 in. (3.2 mm)	1	1
22	◆406488	Collet Body, 5/32 in. (4.0 mm)	1	1
23	◆10N21	Collet, 0.020 in. (0.5 mm)	1	1
23	◆10N22	Collet, 0.040 in. (1.0 mm)	1	1
23	◆10N23	Collet, 1/16 in. (1.6 mm)	1	1
23	◆10N24	Collet, 3/32 in. (2.4 mm)	1	1
23	◆10N25	Collet, 1/8 in. (3.2 mm)	1	1
23	◆54N20	Collet, 5/32 in. (4.0 mm)	1	1
24	◆18CG	Insulator, Nozzle	1	1
25	◆WP-18	Torch Body, 350A W/C (Includes)	1	
	◆18-6N	Nut, Hose	1	
26	◆WP-18V	Torch Body 350A W/C VLV (Includes)		1
	◆18-6N	Nut, Hose		1
27	◆18-7	Insulator, Back Cap	1	1
28	◆VS-2	Knob, Valve		1
29	◆57Y02	Back Cap, Long	1	1

Item No.	Dia. Mkgs.	Part No.	Description	Quantity	
				Model	
				W-350 (WP-18)	W-350V (WP-18V)

**Figure 8-1. Complete Torch Assembly (continued)**

... 30	...	◆300M	.. Back Cap, Medium	1	1
... 31	...	◆57Y04	.. Back Cap, Short	1	1
... 32	...	◆H-200R	.. Handle, Ribbed	1	1
... 33	...	◆H-200	.. Handle, Knurled	1	1
... 34	...	◆40V74	.. Hose, Water 12-1/2 Ft. (3.8 m) Vinyl	1	1
... 34	...	◆40V74R	.. Hose, Water 12-1/2 Ft. (3.8 m) Rubber	1	1
... 34	...	◆41V32	.. Hose, Water 25 Ft (7.6 m) Vinyl	1	1
... 34	...	◆41V32R	.. Hose, Water 25 Ft (7.6 m) Braided	1	1
... 35	...	◆40V75	.. Hose, Gas 12-1/2 Ft (3.8 m) Vinyl	1	1
... 35	...	◆40V75R18	.. Hose, Gas 12-1/2 Ft (3.8 m) Rubber	1	1
... 35	...	◆41V30	.. Hose, Gas 25 Ft (7.6 m) Vinyl	1	1
... 35	...	◆41V30R18	.. Hose, Gas 25 Ft (7.6 m) Braided	1	1
... 36	...	◆40V64	.. Cable, Power 12-1/2 Ft (3.8 m) Vinyl	1	1
... 36	...	◆40V64R	.. Cable, Power 12-1/2 Ft (3.8 m) Rubber	1	1
... 36	...	◆41V29	.. Cable, Power 25 Ft (7.6 m) Vinyl	1	1
... 36	...	◆41V29R	.. Cable, Power 25 Ft (7.6 m) Rubber	1	1
... 37	...	◆WC-3-10	.. Cover, Cable 10 Ft (3.0 m)	1	1
... 37	...	◆WC-3-22	.. Cover, Cable 22 Ft (6.7 m)	1	1
... 38	...	◆45V11	.. Adapter, Power Cable	1	1
... 39	...	◆195377	.. Conn, Water 50mm	1	1
... 39	...	◆195380	.. Adapter, Torch-intnl Style Water(#20)	1	1
... 39	...	◆225028	.. Adapter, Torch-thread Lock Water (7/8 Lht)Sing Wet	1	1
...	...	◆AK3C	.. Kit, Accessory Ceriated	1	1

◆OPTIONAL

BE SURE TO PROVIDE MODEL AND STYLE NUMBER WHEN ORDERING REPLACEMENT PARTS.









# TRUE BLUE<sup>®</sup>

## WARRANTY

Effective January 1, 2015

(Equipment with a serial number preface of MF or newer)

This limited warranty supersedes all previous Miller warranties and is exclusive with no other guarantees or warranties expressed or implied.

### Warranty Questions?

Call  
1-800-4-A-MILLER  
for your local  
Miller distributor.

Your distributor also gives you ...

### Service

You always get the fast, reliable response you need. Most replacement parts can be in your hands in 24 hours.

### Support

Need fast answers to the tough welding questions? Contact your distributor. The expertise of the distributor and Miller is there to help you, every step of the way.

LIMITED WARRANTY – Subject to the terms and conditions below, Miller Electric Mfg. Co., Appleton, Wisconsin, warrants to its original retail purchaser that new Miller equipment sold after the effective date of this limited warranty is free of defects in material and workmanship at the time it is shipped by Miller. THIS WARRANTY IS EXPRESSLY IN LIEU OF ALL OTHER WARRANTIES, EXPRESS OR IMPLIED, INCLUDING THE WARRANTIES OF MERCHANTABILITY AND FITNESS.

Within the warranty periods listed below, Miller will repair or replace any warranted parts or components that fail due to such defects in material or workmanship. Miller must be notified in writing within thirty (30) days of such defect or failure, at which time Miller will provide instructions on the warranty claim procedures to be followed. If notification is submitted as an online warranty claim, the claim must include a detailed description of the fault and the troubleshooting steps taken to identify failed components and the cause of their failure.

Miller shall honor warranty claims on warranted equipment listed below in the event of such a failure within the warranty time periods. All warranty time periods start on the delivery date of the equipment to the original end-user purchaser, and not to exceed twelve months after the equipment is shipped to a North American distributor or eighteen months after the equipment is shipped to an International distributor.

- 5 Years Parts — 3 Years Labor
  - \* Original Main Power Rectifiers Only to Include SCRs, Diodes, and Discrete Rectifier Modules
- 3 Years — Parts and Labor
  - \* Auto-Darkening Helmet Lenses (Except Classic Series) (No Labor)
  - \* Engine Driven Welder/Generators  
**(NOTE: Engines are Warranted Separately by the Engine Manufacturer.)**
  - \* Inverter Power Sources (Unless Otherwise Stated)
  - \* Plasma Arc Cutting Power Sources
  - \* Process Controllers
  - \* Semi-Automatic and Automatic Wire Feeders
  - \* Transformer/Rectifier Power Sources
- 2 Years — Parts and Labor
  - \* Auto-Darkening Helmet Lenses – Classic Series Only (No Labor)
  - \* Fume Extractors – Capture 5, Filtair 400 and Industrial Collector Series
- 1 Year — Parts and Labor Unless Specified
  - \* Automatic Motion Devices
  - \* CoolBelt and CoolBand Blower Unit (No Labor)
  - \* Desiccant Air Dryer System
  - \* External Monitoring Equipment and Sensors
  - \* Field Options  
**(NOTE: Field options are covered for the remaining warranty period of the product they are installed in, or for a minimum of one year — whichever is greater.)**
  - \* RFCS Foot Controls (Except RFCS-RJ45)
  - \* Fume Extractors – Filtair 130, MWX and SWX Series HF Units
  - \* ICE/XT Plasma Cutting Torches (No Labor)
  - \* Induction Heating Power Sources, Coolers  
**(NOTE: Digital Recorders are Warranted Separately by the Manufacturer.)**
  - \* LiveArc Welding Performance Management System
  - \* Load Banks
  - \* Motor-Driven Guns (except Spoolmate Spoolguns)
  - \* PAPR Blower Unit (No Labor)
  - \* Positioners and Controllers
  - \* Racks
  - \* Running Gear/Trailers
  - \* Spot Welders
  - \* Subarc Wire Drive Assemblies
  - \* Water Coolant Systems
  - \* TIG Torches (No Labor)
  - \* Wireless Remote Foot/Hand Controls and Receivers
  - \* Work Stations/Weld Tables (No Labor)

- 6 Months — Parts
  - \* Batteries
  - \* Bernard Guns (No Labor)
  - \* Tregaskiss Guns (No Labor)
- 90 Days — Parts
  - \* Accessory (Kits)
  - \* Canvas Covers
  - \* Induction Heating Coils and Blankets, Cables, and Non-Electronic Controls
  - \* M-Guns
  - \* MIG Guns and Subarc (SAW) Torches
  - \* Remote Controls and RFCS-RJ45
  - \* Replacement Parts (No labor)
  - \* Roughneck Guns
  - \* Spoolmate Spoolguns

Miller's True Blue<sup>®</sup> Limited Warranty shall not apply to:

- Consumable components; such as contact tips, cutting nozzles, contactors, brushes, relays, work station table tops and welding curtains, or parts that fail due to normal wear. (Exception: brushes and relays are covered on all engine-driven products.)**
- Items furnished by Miller, but manufactured by others, such as engines or trade accessories. These items are covered by the manufacturer's warranty, if any.
- Equipment that has been modified by any party other than Miller, or equipment that has been improperly installed, improperly operated or misused based upon industry standards, or equipment which has not had reasonable and necessary maintenance, or equipment which has been used for operation outside of the specifications for the equipment.

MILLER PRODUCTS ARE INTENDED FOR PURCHASE AND USE BY COMMERCIAL/INDUSTRIAL USERS AND PERSONS TRAINED AND EXPERIENCED IN THE USE AND MAINTENANCE OF WELDING EQUIPMENT.

In the event of a warranty claim covered by this warranty, the exclusive remedies shall be, at Miller's option: (1) repair; or (2) replacement; or, where authorized in writing by Miller in appropriate cases, (3) the reasonable cost of repair or replacement at an authorized Miller service station; or (4) payment of or credit for the purchase price (less reasonable depreciation based upon actual use) upon return of the goods at customer's risk and expense. Miller's option of repair or replacement will be F.O.B., Factory at Appleton, Wisconsin, or F.O.B. at a Miller authorized service facility as determined by Miller. Therefore no compensation or reimbursement for transportation costs of any kind will be allowed.

TO THE EXTENT PERMITTED BY LAW, THE REMEDIES PROVIDED HEREIN ARE THE SOLE AND EXCLUSIVE REMEDIES. IN NO EVENT SHALL MILLER BE LIABLE FOR DIRECT, INDIRECT, SPECIAL, INCIDENTAL OR CONSEQUENTIAL DAMAGES (INCLUDING LOSS OF PROFIT), WHETHER BASED ON CONTRACT, TORT OR ANY OTHER LEGAL THEORY.

ANY EXPRESS WARRANTY NOT PROVIDED HEREIN AND ANY IMPLIED WARRANTY, GUARANTY OR REPRESENTATION AS TO PERFORMANCE, AND ANY REMEDY FOR BREACH OF CONTRACT TORT OR ANY OTHER LEGAL THEORY WHICH, BUT FOR THIS PROVISION, MIGHT ARISE BY IMPLICATION, OPERATION OF LAW, CUSTOM OF TRADE OR COURSE OF DEALING, INCLUDING ANY IMPLIED WARRANTY OF MERCHANTABILITY OR FITNESS FOR PARTICULAR PURPOSE, WITH RESPECT TO ANY AND ALL EQUIPMENT FURNISHED BY MILLER IS EXCLUDED AND DISCLAIMED BY MILLER.

Some states in the U.S.A. do not allow limitations of how long an implied warranty lasts, or the exclusion of incidental, indirect, special or consequential damages, so the above limitation or exclusion may not apply to you. This warranty provides specific legal rights, and other rights may be available, but may vary from state to state.

In Canada, legislation in some provinces provides for certain additional warranties or remedies other than as stated herein, and to the extent that they may not be waived, the limitations and exclusions set out above may not apply. This Limited Warranty provides specific legal rights, and other rights may be available, but may vary from province to province.

miller\_warr 2015-01





# Owner's Record

Please complete and retain with your personal records.

Model Name

Serial/Style Number

Purchase Date

(Date which equipment was delivered to original customer.)

Distributor

Address

City

State

Zip



## For Service

Contact a **DISTRIBUTOR** or **SERVICE AGENCY** near you.

Always provide Model Name and Serial/Style Number.

Contact your Distributor for:

Welding Supplies and Consumables

Options and Accessories

Personal Safety Equipment

Service and Repair

Replacement Parts

Training (Schools, Videos, Books)

Technical Manuals (Servicing Information and Parts)

Circuit Diagrams

Welding Process Handbooks

To locate a Distributor or Service Agency visit [www.millerwelds.com](http://www.millerwelds.com) or call 1-800-4-A-Miller

Contact the Delivering Carrier to:

File a claim for loss or damage during shipment.

For assistance in filing or settling claims, contact your distributor and/or equipment manufacturer's Transportation Department.

### Miller Electric Mfg. Co.

An Illinois Tool Works Company  
1635 West Spencer Street  
Appleton, WI 54914 USA

### International Headquarters—USA

USA Phone: 920-735-4505 Auto-Attended  
USA & Canada FAX: 920-735-4134  
International FAX: 920-735-4125

For International Locations Visit  
[www.MillerWelds.com](http://www.MillerWelds.com)

