

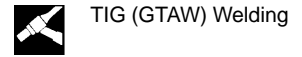

OM-2237 206 035A

March 2002

Processes

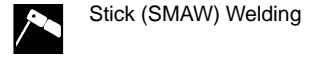

Description



Arc Welding Power Source

CST 250

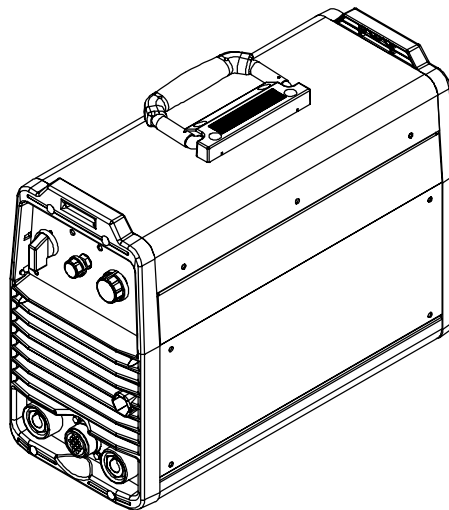

OWNER'S MANUAL



Visit our website at
www.MillerWelds.com

From Miller to You

Thank you and congratulations on choosing Miller. Now you can get the job done and get it done right. We know you don't have time to do it any other way.

That's why when Niels Miller first started building arc welders in 1929, he made sure his products offered long-lasting value and superior quality. Like you, his customers couldn't afford anything less. Miller products had to be more than the best they could be. They had to be the best you could buy.

Today, the people that build and sell Miller products continue the tradition. They're just as committed to providing equipment and service that meets the high standards of quality and value established in 1929.

This Owner's Manual is designed to help you get the most out of your Miller products. Please take time to read the Safety precautions. They will help you protect yourself against potential hazards on the worksite.

We've made installation and operation quick and easy. With Miller you can count on years of reliable service with proper maintenance. And if for some reason the unit needs repair, there's a Troubleshooting section that will help you figure out what the problem is. The parts list will then help you to decide the exact part you may need to fix the problem. Warranty and service information for your particular model are also provided.



Miller is the first welding equipment manufacturer in the U.S.A. to be registered to the ISO 9001 Quality System Standard.

Miller Electric manufactures a full line of welders and welding related equipment. For information on other quality Miller products, contact your local Miller distributor to receive the latest full line catalog or individual catalog sheets. **To locate your nearest distributor or service agency call 1-800-4-A-Miller, or visit us at www.MillerWelds.com on the web.**



Working as hard as you do – every power source from Miller is backed by the most hassle-free warranty in the business.

Miller offers a Technical Manual which provides more detailed service and parts information for your unit. To obtain a Technical Manual, contact your local distributor. Your distributor can also supply you with Welding Process Manuals such as SMAW, GTAW, GMAW, and GMAW-P.



TABLE OF CONTENTS

WARNING

This product, when used for welding or cutting, produces fumes or gases which contain chemicals known to the State of California to cause birth defects and, in some cases, cancer. (California Health & Safety Code Section 25249.5 et seq.)

The following terms are used interchangeably throughout this manual:
TIG = GTAW
Stick = SMAW

SECTION 1 – SAFETY PRECAUTIONS - READ BEFORE USING	1
1-1. Symbol Usage	1
1-2. Arc Welding Hazards	1
1-3. Additional Symbols For Installation, Operation, And Maintenance	3
1-4. Principal Safety Standards	3
1-5. EMF Information	4
SECTION 1 – CONSIGNES DE SECURITE – LIRE AVANT UTILISATION	5
1-1. Signification des symboles	5
1-2. Dangers relatifs au soudage à l'arc	5
1-3. Dangers supplémentaires en relation avec l'installation, le fonctionnement et la maintenance	7
1-4. Principales normes de sécurité	8
1-5. Information sur les champs électromagnétiques	8
SECTION 2 – INSTALLATION	9
2-1. Specifications	9
2-2. Duty Cycle And Overheating	9
2-3. Stick (SMAW) Volt-Ampere Curves	10
2-4. TIG (GTAW) Volt-Ampere Curve	11
2-5. Selecting A Location	12
2-6. Weld Output Terminals And Selecting Cable Sizes*	13
2-7. TIG Lift-Arc DCEN (Direct Current Electrode Negative) Connections	14
2-8. Stick DCEP (Direct Current Electrode Positive) Connections	15
2-9. Electrical Service Guide	15
2-10. Selecting 230 Volts AC Single/Three Phase Input Voltage	16
2-11. Selecting 460/575 Volts AC Three Phase Input Voltage	17
2-12. Connecting Input Power	18
SECTION 3 – OPERATION	19
3-1. Controls	19
3-2. Process Select Control	20
3-3. Stick Start Procedure – Scratch Start Technique	21
3-4. Lift-ArcE Start Procedure	21
3-5. Amperage Control	22
3-6. Remote 14 Receptacle Information	22
3-7. Fan-On-Demand	22
3-8. Rack Mounting	22
SECTION 4 – MAINTENANCE AND TROUBLESHOOTING	23
4-1. Routine Maintenance	23
4-2. Blowing Out Inside Of Unit	23
4-3. Troubleshooting	24
SECTION 5 – ELECTRICAL DIAGRAMS	26
SECTION 6 – SELECTING AND PREPARING TUNGSTEN ELECTRODE	27
6-1. Selecting Tungsten Electrode	27
6-2. Safety Information About Tungsten	27
6-3. Preparing Tungsten For AC Or DC Electrode Negative (DCEN) Welding	28
SECTION 7 – PARTS LIST	30
WARRANTY	

SECTION 1 – SAFETY PRECAUTIONS - READ BEFORE USING

som_nd_4/98

1-1. Symbol Usage



Means Warning! Watch Out! There are possible hazards with this procedure! The possible hazards are shown in the adjoining symbols.

▲ Marks a special safety message.

☞ Means "Note"; not safety related.



This group of symbols means Warning! Watch Out! possible ELECTRIC SHOCK, MOVING PARTS, and HOT PARTS hazards. Consult symbols and related instructions below for necessary actions to avoid the hazards.

1-2. Arc Welding Hazards

▲ The symbols shown below are used throughout this manual to call attention to and identify possible hazards. When you see the symbol, watch out, and follow the related instructions to avoid the hazard. The safety information given below is only a summary of the more complete safety information found in the Safety Standards listed in Section 1-4. Read and follow all Safety Standards.

▲ Only qualified persons should install, operate, maintain, and repair this unit.

▲ During operation, keep everybody, especially children, away.



ELECTRIC SHOCK can kill.

Touching live electrical parts can cause fatal shocks or severe burns. The electrode and work circuit is electrically live whenever the output is on. The input power circuit and machine internal circuits are also

live when power is on. In semiautomatic or automatic wire welding, the wire, wire reel, drive roll housing, and all metal parts touching the welding wire are electrically live. Incorrectly installed or improperly grounded equipment is a hazard.

- Do not touch live electrical parts.
- Wear dry, hole-free insulating gloves and body protection.
- Insulate yourself from work and ground using dry insulating mats or covers big enough to prevent any physical contact with the work or ground.
- Do not use AC output in damp areas, if movement is confined, or if there is a danger of falling.
- Use AC output ONLY if required for the welding process.
- If AC output is required, use remote output control if present on unit.
- Disconnect input power or stop engine before installing or servicing this equipment. Lockout/tagout input power according to OSHA 29 CFR 1910.147 (see Safety Standards).
- Properly install and ground this equipment according to its Owner's Manual and national, state, and local codes.
- Always verify the supply ground – check and be sure that input power cord ground wire is properly connected to ground terminal in disconnect box or that cord plug is connected to a properly grounded receptacle outlet.
- When making input connections, attach proper grounding conductor first – double-check connections.
- Frequently inspect input power cord for damage or bare wiring – replace cord immediately if damaged – bare wiring can kill.
- Turn off all equipment when not in use.
- Do not use worn, damaged, undersized, or poorly spliced cables.
- Do not drape cables over your body.

- If earth grounding of the workpiece is required, ground it directly with a separate cable.
- Do not touch electrode if you are in contact with the work, ground, or another electrode from a different machine.
- Use only well-maintained equipment. Repair or replace damaged parts at once. Maintain unit according to manual.
- Wear a safety harness if working above floor level.
- Keep all panels and covers securely in place.
- Clamp work cable with good metal-to-metal contact to workpiece or worktable as near the weld as practical.
- Insulate work clamp when not connected to workpiece to prevent contact with any metal object.
- Do not connect more than one electrode or work cable to any single weld output terminal.

SIGNIFICANT DC VOLTAGE exists after removal of input power on inverters.

- Turn Off inverter, disconnect input power, and discharge input capacitors according to instructions in Maintenance Section before touching any parts.

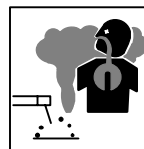

FUMES AND GASES can be hazardous.

Welding produces fumes and gases. Breathing these fumes and gases can be hazardous to your health.

- Keep your head out of the fumes. Do not breathe the fumes.
- If inside, ventilate the area and/or use exhaust at the arc to remove welding fumes and gases.
- If ventilation is poor, use an approved air-supplied respirator.
- Read the Material Safety Data Sheets (MSDSs) and the manufacturer's instructions for metals, consumables, coatings, cleaners, and degreasers.
- Work in a confined space only if it is well ventilated, or while wearing an air-supplied respirator. Always have a trained watch-person nearby. Welding fumes and gases can displace air and lower the oxygen level causing injury or death. Be sure the breathing air is safe.
- Do not weld in locations near degreasing, cleaning, or spraying operations. The heat and rays of the arc can react with vapors to form highly toxic and irritating gases.
- Do not weld on coated metals, such as galvanized, lead, or cadmium plated steel, unless the coating is removed from the weld area, the area is well ventilated, and if necessary, while wearing an air-supplied respirator. The coatings and any metals containing these elements can give off toxic fumes if welded.



ARC RAYS can burn eyes and skin.

Arc rays from the welding process produce intense visible and invisible (ultraviolet and infrared) rays that can burn eyes and skin. Sparks fly off from the weld.

- Wear a welding helmet fitted with a proper shade of filter to protect your face and eyes when welding or watching (see ANSI Z49.1 and Z87.1 listed in Safety Standards).
- Wear approved safety glasses with side shields under your helmet.
- Use protective screens or barriers to protect others from flash and glare; warn others not to watch the arc.
- Wear protective clothing made from durable, flame-resistant material (leather and wool) and foot protection.



WELDING can cause fire or explosion.

Welding on closed containers, such as tanks, drums, or pipes, can cause them to blow up. Sparks can fly off from the welding arc. The flying sparks, hot workpiece, and hot equipment can cause fires and burns. Accidental contact of electrode to metal objects can cause sparks, explosion, overheating, or fire. Check and be sure the area is safe before doing any welding.

- Protect yourself and others from flying sparks and hot metal.
- Do not weld where flying sparks can strike flammable material.
- Remove all flammables within 35 ft (10.7 m) of the welding arc. If this is not possible, tightly cover them with approved covers.
- Be alert that welding sparks and hot materials from welding can easily go through small cracks and openings to adjacent areas.
- Watch for fire, and keep a fire extinguisher nearby.
- Be aware that welding on a ceiling, floor, bulkhead, or partition can cause fire on the hidden side.
- Do not weld on closed containers such as tanks, drums, or pipes, unless they are properly prepared according to AWS F4.1 (see Safety Standards).
- Connect work cable to the work as close to the welding area as practical to prevent welding current from traveling long, possibly unknown paths and causing electric shock and fire hazards.
- Do not use welder to thaw frozen pipes.
- Remove stick electrode from holder or cut off welding wire at contact tip when not in use.
- Wear oil-free protective garments such as leather gloves, heavy shirt, cuffless trousers, high shoes, and a cap.
- Remove any combustibles, such as a butane lighter or matches, from your person before doing any welding.

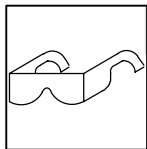

FLYING METAL can injure eyes.

- Welding, chipping, wire brushing, and grinding cause sparks and flying metal. As welds cool, they can throw off slag.
- Wear approved safety glasses with side shields even under your welding helmet.



BUILDUP OF GAS can injure or kill.

- Shut off shielding gas supply when not in use.
- Always ventilate confined spaces or use approved air-supplied respirator.



HOT PARTS can cause severe burns.

- Do not touch hot parts bare handed.
- Allow cooling period before working on gun or torch.

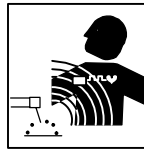

MAGNETIC FIELDS can affect pacemakers.

- Pacemaker wearers keep away.
- Wearers should consult their doctor before going near arc welding, gouging, or spot welding operations.

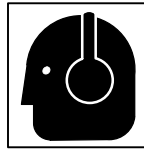

NOISE can damage hearing.

Noise from some processes or equipment can damage hearing.

- Wear approved ear protection if noise level is high.

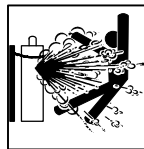

CYLINDERS can explode if damaged.

Shielding gas cylinders contain gas under high pressure. If damaged, a cylinder can explode. Since gas cylinders are normally part of the welding process, be sure to treat them carefully.

- Protect compressed gas cylinders from excessive heat, mechanical shocks, slag, open flames, sparks, and arcs.
- Install cylinders in an upright position by securing to a stationary support or cylinder rack to prevent falling or tipping.
- Keep cylinders away from any welding or other electrical circuits.
- Never drape a welding torch over a gas cylinder.
- Never allow a welding electrode to touch any cylinder.
- Never weld on a pressurized cylinder – explosion will result.
- Use only correct shielding gas cylinders, regulators, hoses, and fittings designed for the specific application; maintain them and associated parts in good condition.
- Turn face away from valve outlet when opening cylinder valve.
- Keep protective cap in place over valve except when cylinder is in use or connected for use.
- Read and follow instructions on compressed gas cylinders, associated equipment, and CGA publication P-1 listed in Safety Standards.

1-3. Additional Symbols For Installation, Operation, And Maintenance



FIRE OR EXPLOSION hazard.

- Do not install or place unit on, over, or near combustible surfaces.
- Do not install unit near flammables.
- Do not overload building wiring – be sure power supply system is properly sized, rated, and protected to handle this unit.



FALLING UNIT can cause injury.

- Use lifting eye to lift unit only, NOT running gear, gas cylinders, or any other accessories.
- Use equipment of adequate capacity to lift and support unit.
- If using lift forks to move unit, be sure forks are long enough to extend beyond opposite side of unit.

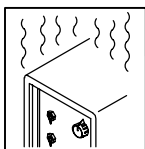

OVERUSE can cause OVERHEATING

- Allow cooling period; follow rated duty cycle.
- Reduce current or reduce duty cycle before starting to weld again.
- Do not block or filter airflow to unit.

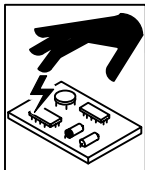

STATIC (ESD) can damage PC boards.

- Put on grounded wrist strap BEFORE handling boards or parts.
- Use proper static-proof bags and boxes to store, move, or ship PC boards.



MOVING PARTS can cause injury.

- Keep away from moving parts.
- Keep away from pinch points such as drive rolls.



WELDING WIRE can cause injury.

- Do not press gun trigger until instructed to do so.
- Do not point gun toward any part of the body, other people, or any metal when threading welding wire.



MOVING PARTS can cause injury.

- Keep away from moving parts such as fans.
- Keep all doors, panels, covers, and guards closed and securely in place.

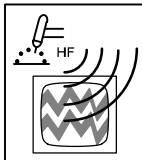

H.F. RADIATION can cause interference.

- High-frequency (H.F.) can interfere with radio navigation, safety services, computers, and communications equipment.
- Have only qualified persons familiar with electronic equipment perform this installation.
- The user is responsible for having a qualified electrician promptly correct any interference problem resulting from the installation.
- If notified by the FCC about interference, stop using the equipment at once.
- Have the installation regularly checked and maintained.
- Keep high-frequency source doors and panels tightly shut, keep spark gaps at correct setting, and use grounding and shielding to minimize the possibility of interference.

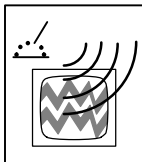

ARC WELDING can cause interference.

- Electromagnetic energy can interfere with sensitive electronic equipment such as computers and computer-driven equipment such as robots.
- Be sure all equipment in the welding area is electromagnetically compatible.
- To reduce possible interference, keep weld cables as short as possible, close together, and down low, such as on the floor.
- Locate welding operation 100 meters from any sensitive electronic equipment.
- Be sure this welding machine is installed and grounded according to this manual.
- If interference still occurs, the user must take extra measures such as moving the welding machine, using shielded cables, using line filters, or shielding the work area.

1-4. Principal Safety Standards

Safety in Welding and Cutting, ANSI Standard Z49.1, from American Welding Society, 550 N.W. LeJeune Rd, Miami FL 33126

Safety and Health Standards, OSHA 29 CFR 1910, from Superintendent of Documents, U.S. Government Printing Office, Washington, D.C. 20402.

Recommended Safe Practices for the Preparation for Welding and Cutting of Containers That Have Held Hazardous Substances, American Welding Society Standard AWS F4.1, from American Welding Society, 550 N.W. LeJeune Rd, Miami, FL 33126

National Electrical Code, NFPA Standard 70, from National Fire Protection Association, Batterymarch Park, Quincy, MA 02269.

Safe Handling of Compressed Gases in Cylinders, CGA Pamphlet P-1, from Compressed Gas Association, 1235 Jefferson Davis Highway, Suite 501, Arlington, VA 22202.

Code for Safety in Welding and Cutting, CSA Standard W117.2, from Canadian Standards Association, Standards Sales, 178 Rexdale Boulevard, Rexdale, Ontario, Canada M9W 1R3.

Safe Practices For Occupation And Educational Eye And Face Protection, ANSI Standard Z87.1, from American National Standards Institute, 1430 Broadway, New York, NY 10018.

Cutting And Welding Processes, NFPA Standard 51B, from National Fire Protection Association, Batterymarch Park, Quincy, MA 02269.

1-5. EMF Information

Considerations About Welding And The Effects Of Low Frequency Electric And Magnetic Fields

Welding current, as it flows through welding cables, will cause electromagnetic fields. There has been and still is some concern about such fields. However, after examining more than 500 studies spanning 17 years of research, a special blue ribbon committee of the National Research Council concluded that: "The body of evidence, in the committee's judgment, has not demonstrated that exposure to power-frequency electric and magnetic fields is a human-health hazard." However, studies are still going forth and evidence continues to be examined. Until the final conclusions of the research are reached, you may wish to minimize your exposure to electromagnetic fields when welding or cutting.

To reduce magnetic fields in the workplace, use the following procedures:

1. Keep cables close together by twisting or taping them.
2. Arrange cables to one side and away from the operator.
3. Do not coil or drape cables around your body.
4. Keep welding power source and cables as far away from operator as practical.
5. Connect work clamp to workpiece as close to the weld as possible.

About Pacemakers:

Pacemaker wearers consult your doctor first. If cleared by your doctor, then following the above procedures is recommended.

SECTION 1 – CONSIGNES DE SECURITE – LIRE AVANT UTILISATION

som_nd_fre 4/98

1-1. Signification des symboles



Signifie Mise en garde ! Soyez vigilant ! Cette procédure présente des risques de danger ! Ceux-ci sont identifiés par des symboles adjacents aux directives.

▲ Identifie un message de sécurité particulier.

Signifie NOTA ; n'est pas relatif à la sécurité.



Ce groupe de symboles signifie Mise en garde ! Soyez vigilant ! Il y a des risques de danger reliés aux CHOCS ÉLECTRIQUES, aux PIÈCES EN MOUVEMENT et aux PIÈCES CHAUDES. Reportez-vous aux symboles et aux directives ci-dessous afin de connaître les mesures à prendre pour éviter tout danger.

1-2. Dangers relatifs au soudage à l'arc

▲ Les symboles présentés ci-après sont utilisés tout au long du présent manuel pour attirer votre attention et identifier les risques de danger. Lorsque vous voyez un symbole, soyez vigilant et suivez les directives mentionnées afin d'éviter tout danger. Les consignes de sécurité présentées ci-après ne font que résumer l'information contenue dans les normes de sécurité énumérées à la section 1-4. Veuillez lire et respecter toutes ces normes de sécurité.

▲ L'installation, l'utilisation, l'entretien et les réparations ne doivent être confiés qu'à des personnes qualifiées.

▲ Au cours de l'utilisation, tenir toute personne à l'écart et plus particulièrement les enfants.



UN CHOC ÉLECTRIQUE peut tuer.

Un simple contact avec des pièces électriques peut provoquer une électrocution ou des blessures graves. L'électrode et le circuit de soudage sont sous tension dès que l'appareil est sur ON. Le circuit d'entrée et les circuits internes de l'appareil sont également sous tension à ce moment-là. En soudage semi-automatique ou automatique, le fil, le dévidoir, le logement des galets d'entraînement et les pièces métalliques en contact avec le fil de soudage sont sous tension. Des matériels mal installés ou mal mis à la terre présentent un danger.

- Ne jamais toucher les pièces électriques sous tension.
- Porter des gants et des vêtements de protection secs ne comportant pas de trous.
- S'isoler de la pièce et de la terre au moyen de tapis ou d'autres moyens isolants suffisamment grands pour empêcher le contact physique éventuel avec la pièce ou la terre.
- Ne pas se servir de source électrique à courant électrique dans les zones humides, dans les endroits confinés ou là où on risque de tomber.
- Se servir d'une source électrique à courant électrique UNIQUEMENT si le procédé de soudage le demande.
- Si l'utilisation d'une source électrique à courant électrique s'avère nécessaire, se servir de la fonction de télécommande si l'appareil en est équipé.
- Couper l'alimentation ou arrêter le moteur avant de procéder à l'installation, à la réparation ou à l'entretien de l'appareil. Déverrouiller l'alimentation selon la norme OSHA 29 CFR 1910.147 (voir normes de sécurité).
- Installer et mettre à la terre correctement cet appareil conformément à son manuel d'utilisation et aux codes nationaux, provinciaux et municipaux.
- Toujours vérifier la terre du cordon d'alimentation – Vérifier et s'assurer que le fil de terre du cordon d'alimentation est bien raccordé à la borne de terre du sectionneur ou que la fiche du cordon est raccordée à une prise correctement mise à la terre.
- En effectuant les raccordements d'entrée fixer d'abord le conducteur de mise à la terre approprié et contre-vérifier les connexions.
- Vérifier fréquemment le cordon d'alimentation pour voir s'il n'est pas endommagé ou dénudé – remplacer le cordon immédiatement s'il est endommagé – un câble dénudé peut provoquer une électrocution.
- Mettre l'appareil hors tension quand on ne l'utilise pas.
- Ne pas utiliser des câbles usés, endommagés, de grosseur insuffisante ou mal épissés.
- Ne pas enrouler les câbles autour du corps.
- Si la pièce soudée doit être mise à la terre, le faire directement avec un câble distinct.
- Ne pas toucher l'électrode quand on est en contact avec la pièce, la terre ou une électrode provenant d'une autre machine.

- N'utiliser qu'un matériel en bon état. Réparer ou remplacer sur-le-champ les pièces endommagées. Entretien l'appareil conformément à ce manuel.
- Porter un harnais de sécurité quand on travaille en hauteur.
- Maintenir solidement en place tous les panneaux et capots.
- Fixer le câble de retour de façon à obtenir un bon contact métal-métal avec la pièce à souder ou la table de travail, le plus près possible de la soudure.
- Isoler la pince de masse quand pas mis à la pièce pour éviter le contact avec tout objet métallique.

Il y a DU COURANT CONTINU IMPORTANT dans les convertisseurs après la suppression de l'alimentation électrique.

- Arrêter les convertisseurs, débrancher le courant électrique, et décharger les condensateurs d'alimentation selon les instructions indiquées dans la partie entretien avant de toucher les pièces.

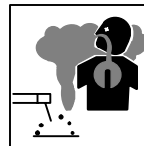

LES FUMÉES ET LES GAZ peuvent être dangereux.

Le soudage génère des fumées et des gaz. Leur inhalation peut être dangereuse pour votre santé.

- Eloigner votre tête des fumées. Ne pas respirer les fumées.
- A l'intérieur, ventiler la zone et/ou utiliser un échappement au niveau de l'arc pour l'évacuation des fumées et des gaz de soudage.
- Si la ventilation est insuffisante, utiliser un respirateur à alimentation d'air homologué.
- Lire les spécifications de sécurité des matériaux (MSDSs) et les instructions du fabricant concernant les métaux, les consommables, les revêtements, les nettoyants et les dégraissants.
- Travailler dans un espace fermé seulement s'il est bien ventilé et en portant un respirateur à alimentation d'air. Demander toujours à un surveillant dûment formé de se tenir à proximité. Des fumées et des gaz de soudage peuvent déplacer l'air et abaisser le niveau d'oxygène provoquant des blessures ou des accidents mortels. S'assurer que l'air de respiration ne présente aucun danger.
- Ne pas souder dans des endroits situés à proximité d'opérations de dégraissage, de nettoyage ou de pulvérisation. La chaleur et les rayons de l'arc peuvent réagir en présence de vapeurs et former des gaz hautement toxiques et irritants.
- Ne pas souder des métaux munis d'un revêtement, tels que l'acier galvanisé, plaqué en plomb ou au cadmium à moins que le revêtement n'ait été enlevé dans la zone de soudure, que l'endroit soit bien ventilé, et si nécessaire, en portant un respirateur à alimentation d'air. Les revêtements et tous les métaux renfermant ces éléments peuvent dégager des fumées toxiques en cas de soudage.



LES RAYONS DE L'ARC peuvent provoquer des brûlures dans les yeux et sur la peau.

Le rayonnement de l'arc du procédé de soudage génère des rayons visibles et invisibles intenses (ultraviolets et infrarouges) susceptibles de provoquer des brûlures dans les yeux et sur la peau. Des étincelles sont projetées pendant le soudage.

- Porter un casque de soudage muni d'un écran de filtre approprié pour protéger votre visage et vos yeux pendant le soudage ou pour regarder (voir ANSI Z49.1 et Z87.1 énuméré dans les normes de sécurité).
- Porter des protections approuvés pour les oreilles si le niveau sonore est trop élevé.
- Utiliser des écrans ou des barrières pour protéger des tiers de l'éclair et de l'éblouissement; demander aux autres personnes de ne pas regarder l'arc.
- Porter des vêtements de protection constitué dans une matière durable, résistant au feu (cuir ou laine) et une protection des pieds.



LE SOUDAGE peut provoquer un incendie ou une explosion.

Le soudage effectué sur des conteneurs fermés tels que des réservoirs, tambours ou des conduites peut provoquer leur éclatement. Des étincelles peuvent être projetées de l'arc de soudure. La projection d'étincelles, des pièces chaudes et des équipements chauds peut provoquer des incendies et des brûlures. Le contact accidentel de l'électrode avec des objets métalliques peut provoquer des étincelles, une explosion, un surchauffement ou un incendie. Avant de commencer le soudage, vérifier et s'assurer que l'endroit ne présente pas de danger.

- Se protéger et d'autres personnes de la projection d'étincelles et de métal chaud.
- Ne pas souder dans un endroit là où des étincelles peuvent tomber sur des substances inflammables.
- Déplacer toutes les substances inflammables à une distance de 10,7 m de l'arc de soudage. En cas d'impossibilité les recouvrir soigneusement avec des protections homologués.
- Des étincelles et des matériaux chauds du soudage peuvent facilement passer dans d'autres zones en traversant de petites fissures et des ouvertures.
- Surveiller tout déclenchement d'incendie et tenir un extincteur à proximité.
- Le soudage effectué sur un plafond, plancher, paroi ou séparation peut déclencher un incendie de l'autre côté.
- Ne pas effectuer le soudage sur des conteneurs fermés tels que des réservoirs, tambours, ou conduites, à moins qu'ils n'aient été préparés correctement conformément à AWS F4.1 (voir les normes de sécurité).
- Brancher le câble sur la pièce le plus près possible de la zone de soudage pour éviter le transport du courant sur une longue distance par des chemins inconnus éventuels en provoquant des risques d'électrocution et d'incendie.
- Ne pas utiliser le poste de soudage pour décongeler des conduites gelées.
- En cas de non utilisation, enlever la bague d'électrode du porte-électrode ou couper le fil à la pointe de contact.
- Porter des vêtements de protection dépourvus d'huile tels que des gants en cuir, une chemise en matériau lourd, des pantalons sans revers, des chaussures hautes et un couvre chef.
- Avant de souder, retirer toute substance combustible de vos poches telles qu'un allumeur au butane ou des allumettes.

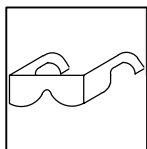

DES PARTICULES VOLANTES peuvent blesser les yeux.

- Le soudage, l'écaillage, le passage de la pièce à la brosse en fil de fer, et le meulage génèrent des étincelles et des particules métalliques volantes. Pendant la période de refroidissement des soudures, elles risquent de projeter du laitier.
- Porter des lunettes de sécurité avec écrans latéraux ou un écran facial.



LES ACCUMULATIONS DE GAZ risquent de provoquer des blessures ou même la mort.

- Fermer l'alimentation du gaz protecteur en cas de non utilisation.
- Veiller toujours à bien aérer les espaces confinés ou se servir d'un respirateur d'adduction d'air homologué.



DES PIÈCES CHAUDES peuvent provoquer des brûlures graves.

- Ne pas toucher des parties chaudes à mains nues
- Prévoir une période de refroidissement avant d'utiliser le pistolet ou la torche.

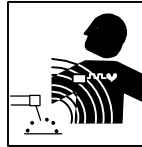

LES CHAMPS MAGNÉTIQUES peuvent affecter les stimulateurs cardiaques.

- Porteurs de stimulateur cardiaque, restez à distance.
- Les porteurs d'un stimulateur cardiaque doivent d'abord consulter leur médecin avant de s'approcher des opérations de soudage à l'arc, de gougeage ou de soudage par points.

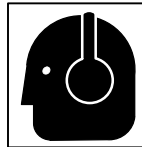

LE BRUIT peut affecter l'ouïe.

Le bruit des processus et des équipements peut affecter l'ouïe.

- Porter des protections approuvés pour les oreilles si le niveau sonore est trop élevé.

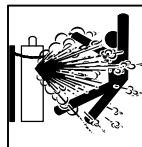

Si des BOUTEILLES sont endommagées, elles pourront exploser.

Des bouteilles de gaz protecteur contiennent du gaz sous haute pression. Si une bouteille est endommagée, elle peut exploser. Du fait que les bouteilles de gaz font normalement partie du procédé de soudage, les manipuler avec précaution.

- Protéger les bouteilles de gaz comprimé d'une chaleur excessive, des chocs mécaniques, du laitier, des flammes ouvertes, des étincelles et des arcs.
- Placer les bouteilles debout en les fixant dans un support stationnaire ou dans un porte-bouteilles pour les empêcher de tomber ou de se renverser.
- Tenir les bouteilles éloignées des circuits de soudage ou autres circuits électriques.
- Ne jamais placer une torche de soudage sur une bouteille à gaz.
- Une électrode de soudage ne doit jamais entrer en contact avec une bouteille.
- Ne jamais souder une bouteille pressurisée – risque d'explosion.
- Utiliser seulement des bouteilles de gaz protecteur, régulateurs, tuyaux et raccords convenables pour cette application spécifique; les maintenir ainsi que les éléments associés en bon état.
- Ne pas tenir la tête en face de la sortie en ouvrant la soupape de la bouteille.
- Maintenir le chapeau de protection sur la soupape, sauf en cas d'utilisation ou de branchement de la bouteille.
- Lire et suivre les instructions concernant les bouteilles de gaz comprimé, les équipements associés et les publications P-1 CGA énumérées dans les normes de sécurité.

1-3. Dangers supplémentaires en relation avec l'installation, le fonctionnement et la maintenance



Risque D'INCENDIE OU D'EXPLOSION.

- Ne pas placer l'appareil sur, au-dessus ou à proximité de surfaces inflammables.
- Ne pas installer l'appareil à proximité de produits inflammables
- Ne pas surcharger l'installation électrique – s'assurer que l'alimentation est correctement dimensionnée et protégé avant de mettre l'appareil en service.



LA CHUTE DE L'APPAREIL peut blesser.

- Utiliser l'anneau de levage uniquement pour soulever l'appareil, NON PAS les chariot, les bouteilles de gaz ou tout autre accessoire.
- Utiliser un engin d'une capacité appropriée pour soulever l'appareil.
- En utilisant des fourches de levage pour déplacer l'unité, s'assurer que les fourches sont suffisamment longues pour dépasser du côté opposé de l'appareil.

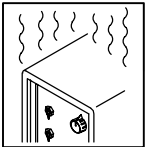

L'EMPLOI EXCESSIF peut SURCHAUFFER L'ÉQUIPEMENT.

- Prévoir une période de refroidissement, respecter le cycle opératoire nominal.
- Réduire le courant ou le cycle opératoire avant de recommencer le soudage.
- Ne pas obstruer les passages d'air du poste.

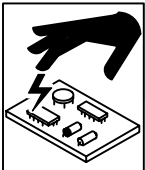

LES CHARGES ÉLECTROSTATIQUES peuvent endommager les circuits imprimés.

- Établir la connexion avec la barrette de terre avant de manipuler des cartes ou des pièces.
- Utiliser des pochettes et des boîtes antistatiques pour stocker, déplacer ou expédier des cartes de circuits imprimés.



DES ORGANES MOBILES peuvent provoquer des blessures.

- Ne pas s'approcher des organes mobiles.
- Ne pas s'approcher des points de coincement tels que des rouleaux de commande.



LES FILS DE SOUDAGE peuvent provoquer des blessures.

- Ne pas appuyer sur la gachette avant d'en avoir reçu l'instruction.
- Ne pas diriger le pistolet vers soi, d'autres personnes ou toute pièce mécanique en engageant le fil de soudage.



DES ORGANES MOBILES peuvent provoquer des blessures.

- Rester à l'écart des organes mobiles comme le ventilateur.
- Maintenir fermés et fixement en place les portes, panneaux, recouvrements et dispositifs de protection.

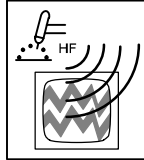

LE RAYONNEMENT HAUTE FRÉQUENCE (H.F.) risque de provoquer des interférences.

- Le rayonnement haute fréquence peut provoquer des interférences avec les équipements de radio-navigation et de communication, les services de sécurité et les ordinateurs.
- Demander seulement à des personnes qualifiées familiarisées avec des équipements électroniques de faire fonctionner l'installation.
- L'utilisateur est tenu de faire corriger rapidement par un électricien qualifié les interférences résultant de l'installation.
- Si le FCC signale des interférences, arrêter immédiatement l'appareil.
- Effectuer régulièrement le contrôle et l'entretien de l'installation.
- Maintenir soigneusement fermés les portes et les panneaux des sources de haute fréquence, maintenir les éclateurs à une distance correcte et utiliser une terre et un blindage pour réduire les interférences éventuelles.

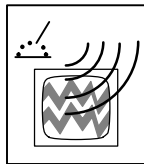

LE SOUDAGE À L'ARC risque de provoquer des interférences.

- L'énergie électromagnétique risque de provoquer des interférences pour l'équipement électronique sensible tel que les ordinateurs et l'équipement commandé par ordinateur tel que les robots.
- Veiller à ce que tout l'équipement de la zone de soudage soit compatible électromagnétiquement.
- Pour réduire la possibilité d'interférence, maintenir les câbles de soudage aussi courts que possible, les grouper, et les poser aussi bas que possible (ex. par terre).
- Veiller à souder à une distance de 100 mètres de tout équipement électronique sensible.
- Veiller à ce que ce poste de soudage soit posé et mis à la terre conformément à ce mode d'emploi.
- En cas d'interférences après avoir pris les mesures précédentes, il incombe à l'utilisateur de prendre des mesures supplémentaires telles que le déplacement du poste, l'utilisation de câbles blindés, l'utilisation de filtres de ligne ou la pose de protecteurs dans la zone de travail.

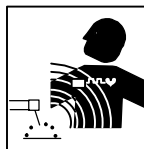

LES CHAMPS MAGNÉTIQUES peuvent affecter les stimulateurs cardiaques.

- Porteurs de stimulateur cardiaque, restez à distance.
- Les porteurs d'un stimulateur cardiaque doivent d'abord consulter leur médecin avant de s'approcher des opérations de soudage à l'arc, de gougeage ou de soudage par points.

1-4. Principales normes de sécurité

Safety in Welding and Cutting, norme ANSI Z49.1, de l'American Welding Society, 550 N.W. Lejeune Rd, Miami FL 33126

Safety and Health Standards, OSHA 29 CFR 1910, du Superintendent of Documents, U.S. Government Printing Office, Washington, D.C. 20402.

Recommended Safe Practice for the Preparation for Welding and Cutting of Containers That Have Held Hazardous Substances, norme AWS F4.1, de l'American Welding Society, 550 N.W. Lejeune Rd, Miami FL 33126

National Electrical Code, NFPA Standard 70, de la National Fire Protection Association, Batterymarch Park, Quincy, MA 02269.

Safe Handling of Compressed Gases in Cylinders, CGA Pamphlet P-1, de la Compressed Gas Association, 1235 Jefferson Davis Highway, Suite 501, Arlington, VA 22202.

Règles de sécurité en soudage, coupage et procédés connexes, norme CSA W117.2, de l'Association canadienne de normalisation, vente de normes, 178 Rexdale Boulevard, Rexdale (Ontario) Canada M9W 1R3.

Safe Practices For Occupation And Educational Eye And Face Protection, norme ANSI Z87.1, de l'American National Standards Institute, 1430 Broadway, New York, NY 10018.

Cutting and Welding Processes, norme NFPA 51B, de la National Fire Protection Association, Batterymarch Park, Quincy, MA 02269.

1-5. Information sur les champs électromagnétiques

Données sur le soudage électrique et sur les effets, pour l'organisme, des champs magnétiques basse fréquence

Le courant de soudage, pendant son passage dans les câbles de soudage, causera des champs électromagnétiques. Il y a eu et il y a encore un certain souci à propos de tels champs. Cependant, après avoir examiné plus de 500 études qui ont été faites pendant une période de recherche de 17 ans, un comité spécial ruban bleu du National Research Council a conclu: "L'accumulation de preuves, suivant le jugement du comité, n'a pas démontré que l'exposition aux champs magnétiques et champs électriques à haute fréquence représente un risque à la santé humaine". Toutefois, des études sont toujours en cours et les preuves continuent à être examinées. En attendant que les conclusions finales de la recherche soient établies, il vous serait souhaitable de réduire votre exposition aux champs électromagnétiques pendant le soudage ou le coupage.

Afin de réduire les champs électromagnétiques dans l'environnement de travail, respecter les consignes suivantes :

- 1 Garder les câbles ensemble en les torsadant ou en les attachant avec du ruban adhésif.
- 2 Mettre tous les câbles du côté opposé de l'opérateur.
- 3 Ne pas courber pas et ne pas entourer pas les câbles autour de votre corps.
- 4 Garder le poste de soudage et les câbles le plus loin possible de vous.
- 5 Relier la pince de masse le plus près possible de la zone de soudure.

Consignes relatives aux stimulateurs cardiaques :

Les personnes qui portent un stimulateur cardiaque doivent avant tout consulter leur docteur. Si vous êtes déclaré apte par votre docteur, il est alors recommandé de respecter les consignes ci-dessus.



SECTION 2 – INSTALLATION

2-1. Specifications

Welding Mode	Input Power	Rated Output	Welding Amperage Range	Maximum Open-Circuit Voltage	Amperes Input At Rated Load Output, 50/60 Hz			KVA	KW	Dimensions	Net Weight
					230	460	575				
Stick (SMAW)	3-Phase	250 A @ 30 VDC, 50 % Duty Cycle	5-250 A	77 VDC	30.5	14.7	11.6	11.7	8.6	H: 13-1/2 in (343 mm) W: 7-1/2 in (191 mm) D: 18 in (457 mm)	40 lb (18.2 kg)
		200 A @ 28 VDC, 100 % Duty Cycle			21.7	11.4	9.2				
	1-Phase	200 A @ 28 VDC, 50 % Duty Cycle	5-200 A	65 VDC	42.6†	n/a	n/a	9.8	6.5		
		150 A @ 26 VDC, 100 % Duty Cycle			30.4†	n/a	n/a	6.9	4.4		

† The primary input current draw is limited to 50 amperes; therefore, on 230 volts single phase, the unit may not make rating.

2-2. Duty Cycle And Overheating

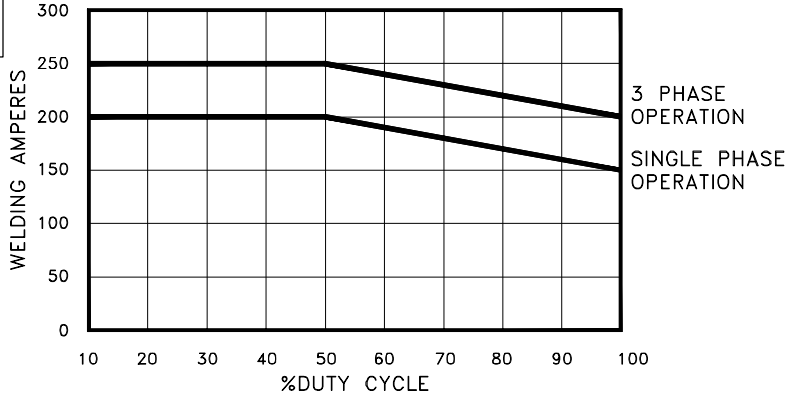

Duty Cycle is percentage of 10 minutes that unit can weld at rated load without overheating.

If unit overheats, output stops, and cooling fan runs. Wait fifteen minutes for unit to cool. Reduce amperage or duty cycle before welding.

▲ Exceeding duty cycle can damage unit and void warranty.

206 173

200 A @ 50% Duty Cycle For Single Phase Operation

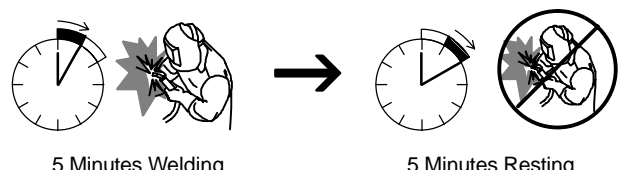

250 A @ 50% Duty Cycle For 3 Phase Operation

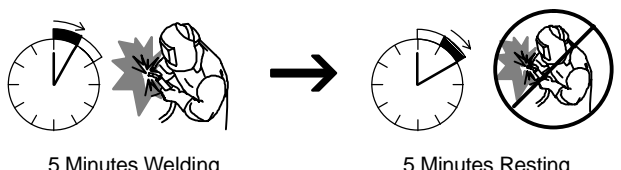

Overheating

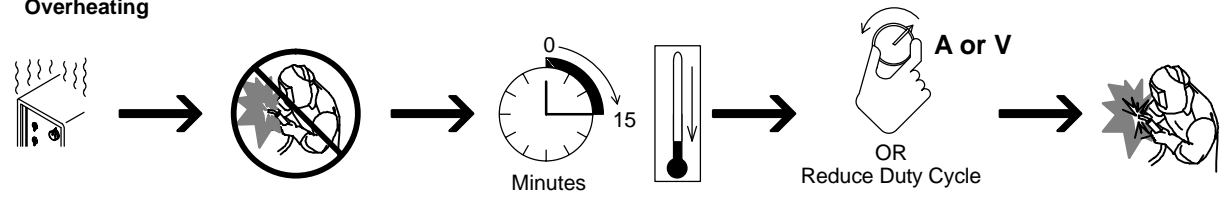

2-3. Stick (SMAW) Volt-Ampere Curves

xx10 Stick VA Curve

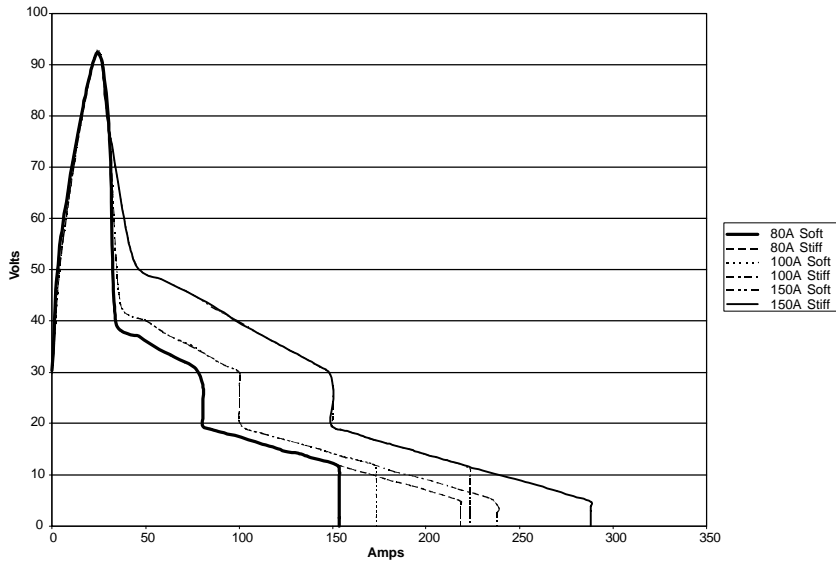

Volt-ampere curves show minimum and maximum voltage and amperage output capabilities of welding power source. Curves of other settings fall between curves shown.

xx18 Stick VA Curve

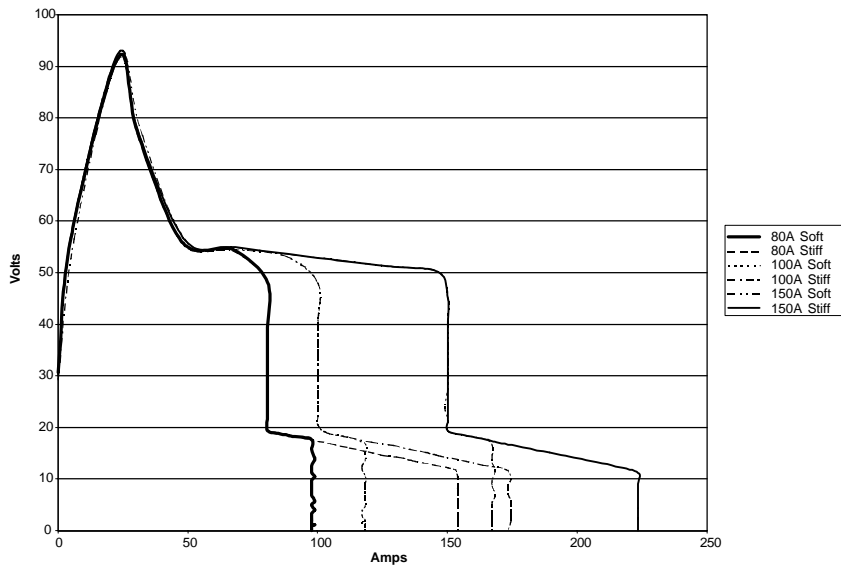

100 Amp VA Curve

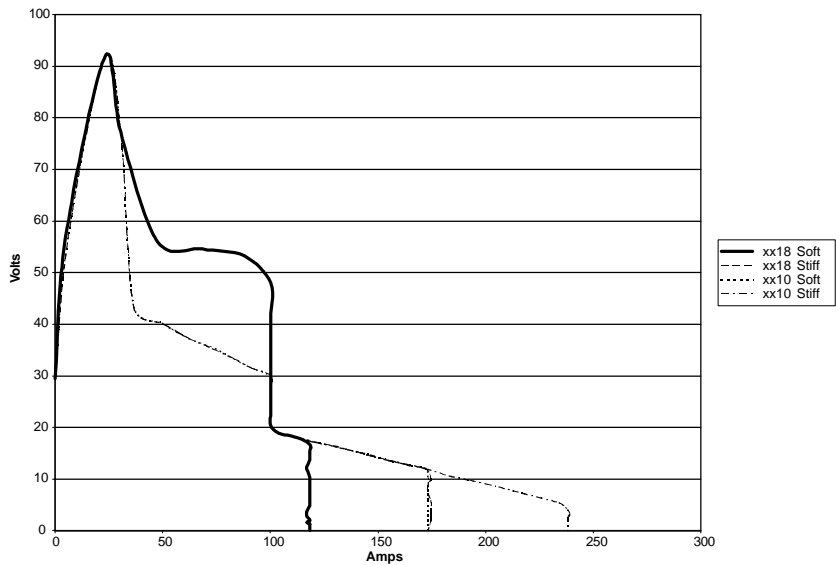

2-4. TIG (GTAW) Volt-Ampere Curve

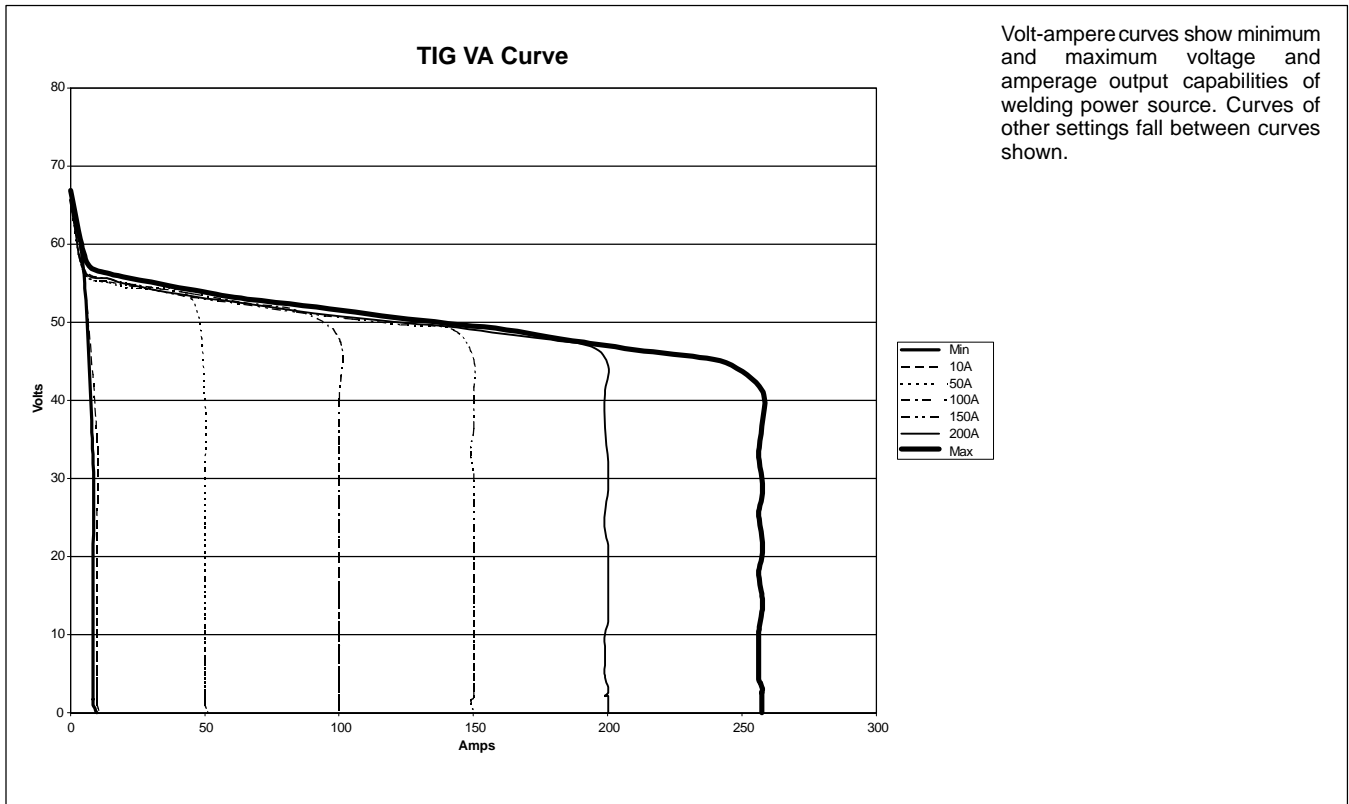

2-5. Selecting A Location



Dimensions And Weight

40 lb (18.2 kg) - with power cord

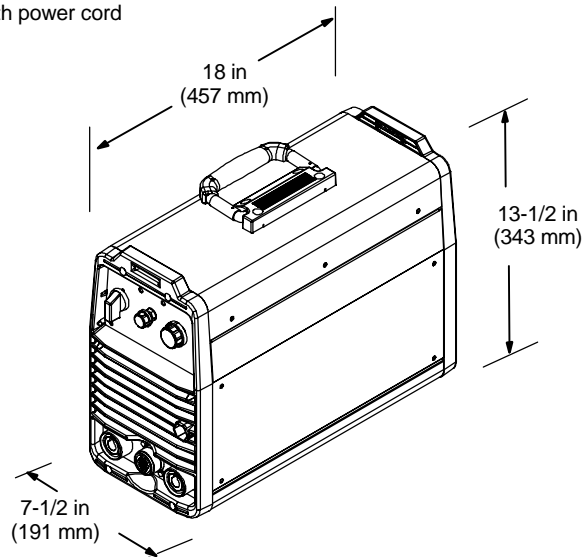

1 Line Disconnect Device

Locate unit near correct input power supply.

▲ **Special installation may be required where gasoline or volatile liquids are present – see NEC Article 511 or CEC Section 20.**

Location And Airflow

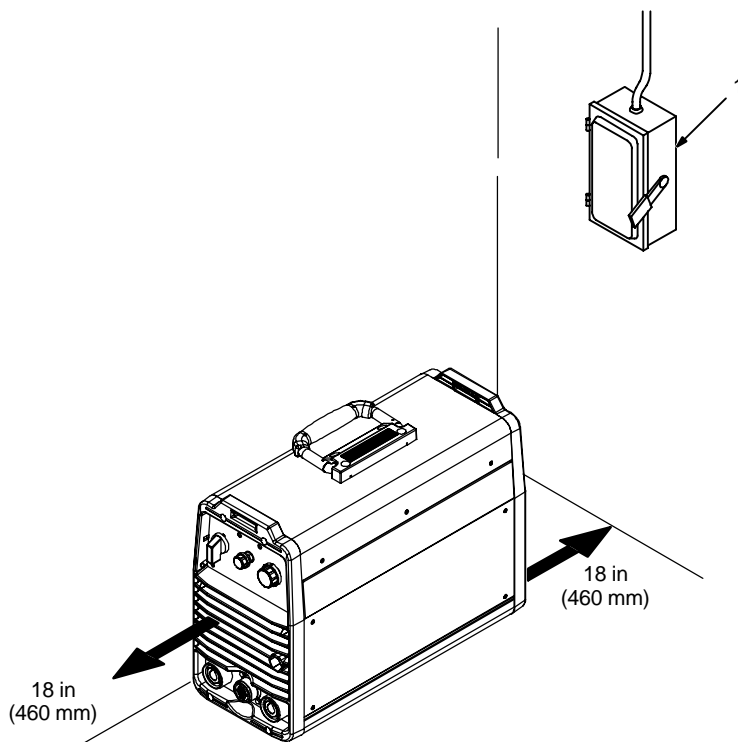

803 080

2-6. Weld Output Terminals And Selecting Cable Sizes*

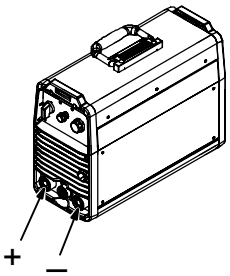
	Weld Cable Size** and Total Cable (Copper) Length in Weld Circuit Not Exceeding								
	100 ft (30 m) Or Less		150 ft (45 m)	200 ft (60 m)	250 ft (70 m)	300 ft (90 m)	350 ft (105 m)	400 ft (120 m)	
Weld Output Terminals	Welding Amperes***	10 – 60% Duty Cycle	60 – 100% Duty Cycle	10 – 100% Duty Cycle					
 + - Output Receptacles	100	4 (20)	4 (20)	4 (20)	3 (30)	2 (35)	1 (50)	1/0 (60)	1/0 (60)
	150	3 (30)	3 (30)	2 (35)	1 (50)	1/0 (60)	2/0 (70)	3/0 (95)	3/0 (95)
	200	3 (30)	2 (35)	1 (50)	1/0 (60)	2/0 (70)	3/0 (95)	4/0 (120)	4/0 (120)
	250	2 (35)	1 (50)	1/0 (60)	2/0 (70)	3/0 (95)	4/0 (120)	2 ea. 2/0 (2x70)	2 ea. 2/0 (2x70)
	300	1 (50)	1/0 (60)	2/0 (70)	3/0 (95)	4/0 (120)	2 ea. 2/0 (2x70)	2 ea. 3/0 (2x95)	2 ea. 3/0 (2x95)

* This chart is a general guideline and may not suit all applications. If cable overheating occurs (normally you can smell it), use next size larger cable.

**Weld cable size (AWG) is based on either a 4 volts or less drop or a current density of at least 300 circular mils per ampere.
 () = mm² for metric use

***Select weld cable size for pulsing application at peak amperage value.

S-0007-E-803 080

2-7. TIG Lift-Arc™ DCEN (Direct Current Electrode Negative) Connections

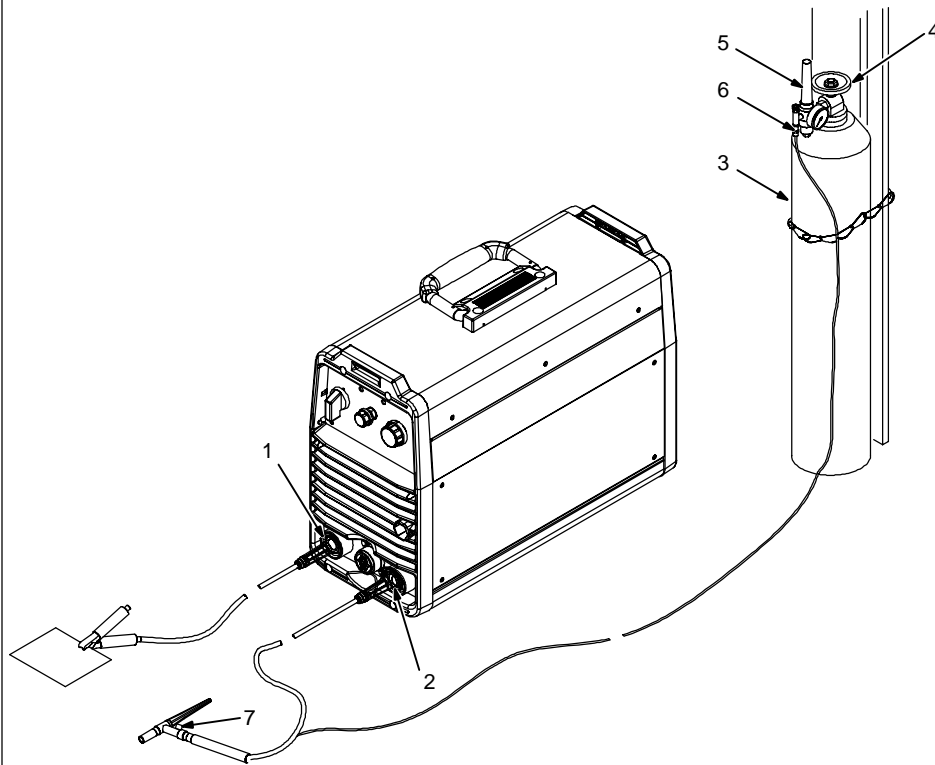

1 Positive (+) Weld Output Terminal

Connect work lead to positive weld output terminal.

2 Negative (-) Weld Output Terminal

Connect TIG torch to negative weld output terminal.

3 Gas Cylinder

4 Cylinder Valve

Open valve slightly so gas flow blows dirt from valve. Close valve.

5 Regulator/Flowmeter

6 Flow Adjust

Typical flow rate is 15 cubic feet per hour (7.1 liters per minute).

Connect torch gas hose to regulator/flowmeter

7 Gas Valve

Valve controls gas preflow and postflow. Open valve on torch just before welding.

Tools Needed:

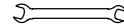

11/16 in, 1-1/8 in, (21 mm)

Ref. 802 888 / Ref. 803 080

2-8. Stick DCEP (Direct Current Electrode Positive) Connections



1 Negative (-) Weld Output Terminal

Connect work lead to negative weld output terminal.

2 Positive (+) Weld Output Terminal

Connect electrode holder to positive weld output terminal.

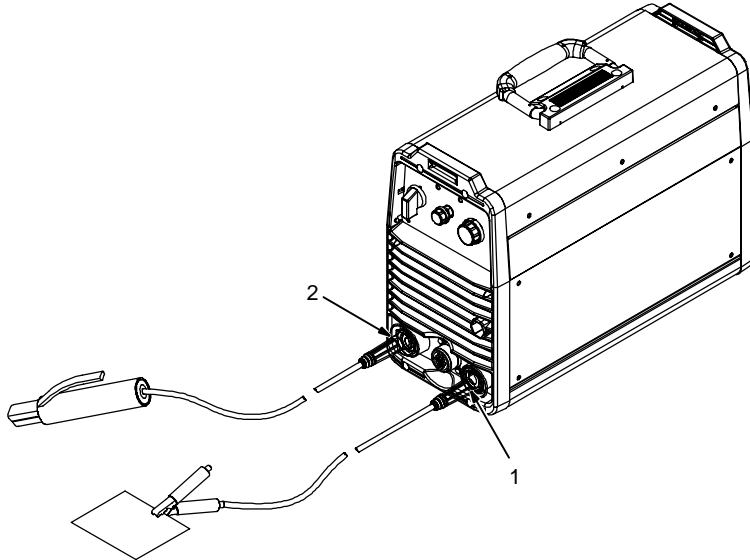

Ref. 802 888 / Ref. 803 080

2-9. Electrical Service Guide

▲ CAUTION: INCORRECT INPUT POWER can damage this welding power source. This welding power source requires a **CONTINUOUS** supply of 60 Hz ($\pm 10\%$) power at $\pm 10\%$ of rated input voltage. Do not use a generator with automatic idle device (that idles engine when no load is sensed) to supply input power to this welding power source.

NOTE

Actual input voltage cannot exceed $\pm 10\%$ of indicated required input voltage. If actual input voltage is outside of this range, no output is available.

	50/60 Hz Single-Phase, 50% Duty Cycle	50/60 Hz Three-Phase, 50% Duty Cycle		
Input Voltage	230	230	460	575
Input Amperes At Rated Output	43	29	15	12
Max Recommended Standard Fuse Rating In Amperes ¹				
Time-Delay ²	50	35	15	10
Normal Operating ³	60	45	20	15
Min Input Conductor Size In AWG/Kcmil	8	10	14	14
Max Recommended Input Conductor Length In Feet (Meters)	143 (44)	147 (45)	233 (71)	364 (111)
Min Grounding Conductor Size In AWG/Kcmil	10	10	14	14

Reference: 1999 National Electrical Code (NEC)

1 Consult factory for circuit breaker applications.

2 "Time-Delay" fuses are UL class "RK5".

3 "Normal Operating" (general purpose - no intentional delay) fuses are UL class "K5" (up to and including 60 amp), and UL class "H" (65 amp and above).

2-10. Selecting 230 Volts AC Single/Three Phase Input Voltage

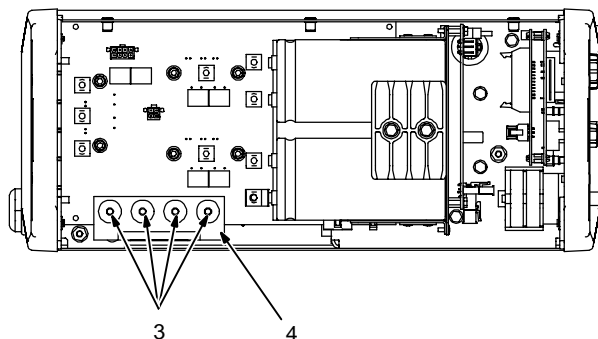
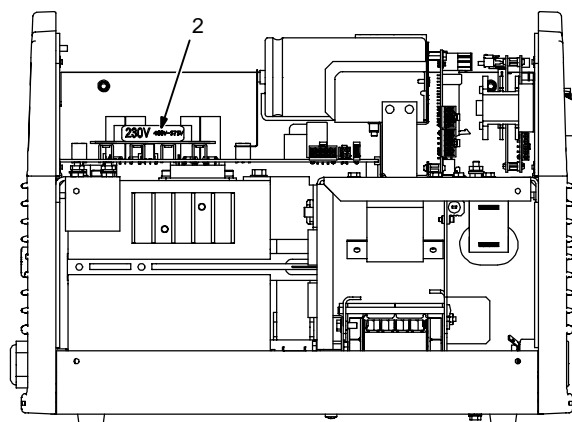
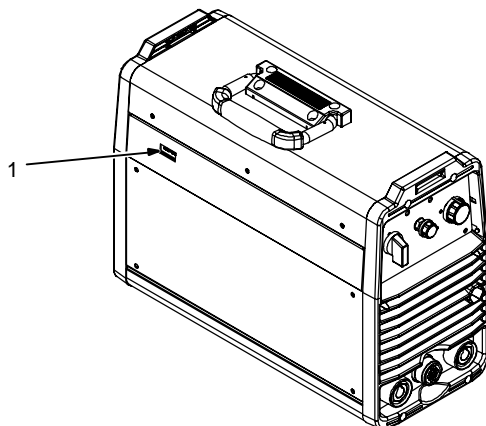

▲ Turn Off welding power source, and disconnect input power before proceeding.

Check input voltage available at site.

1 Voltage Selection View Window

The input voltage that the power source is linked for appears in the Voltage Selection View Window.

Check voltage selected in unit. Changing selection is only necessary if selected value does not match available input voltage.

To change relinking board position, remove top cover and left side panel.

2 Relinking Board

3 Terminal Screws

Loosen terminal screws.

4 Relinking Board (Connection For 230 VAC Single/Three Phase Input Power)

Slide relinking board off connected terminals, move relinking board to correct input voltage terminals, and secure relinking board.

☞ Be sure to tighten all four screws securing relinking board in place.

Tools Needed:



5/16 in

803 079 / 803 077

2-11. Selecting 460/575 Volts AC Three Phase Input Voltage



▲ Turn Off welding power source, and disconnect input power before proceeding.

Check input voltage available at site.

1 Voltage Selection View Window

The input voltage that the power source is linked for appears in the Voltage Selection View Window.

Check voltage selected in unit. Changing selection is only necessary if selected value does not match available input voltage.

To change relinking board position, remove top cover and left side panel.

2 Relinking Board
3 Unused Terminal
4 Terminal Screws

Loosen terminal screws.

5 Relinking Board (Connection For 460/575 VAC Input Power)

Slide relinking board off connected terminals, move relinking board to correct input voltage terminals, and secure relinking board.

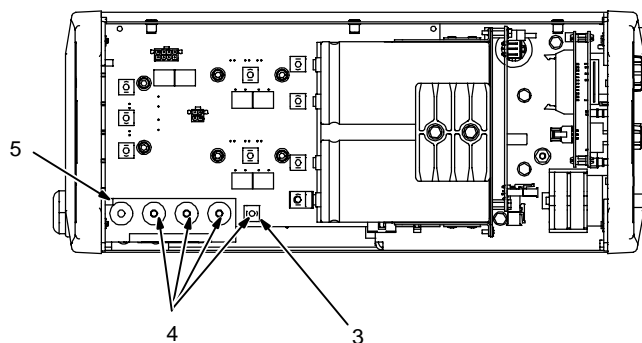
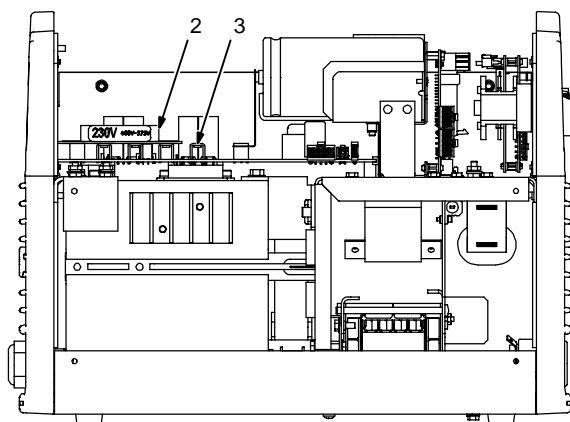
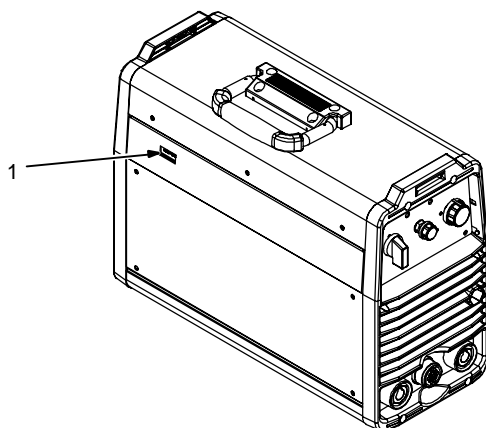

☞ Be sure to tighten all four screws. Three screws securing relinking board in place.

Tools Needed:

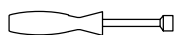

5/16 in

2-12. Connecting Input Power

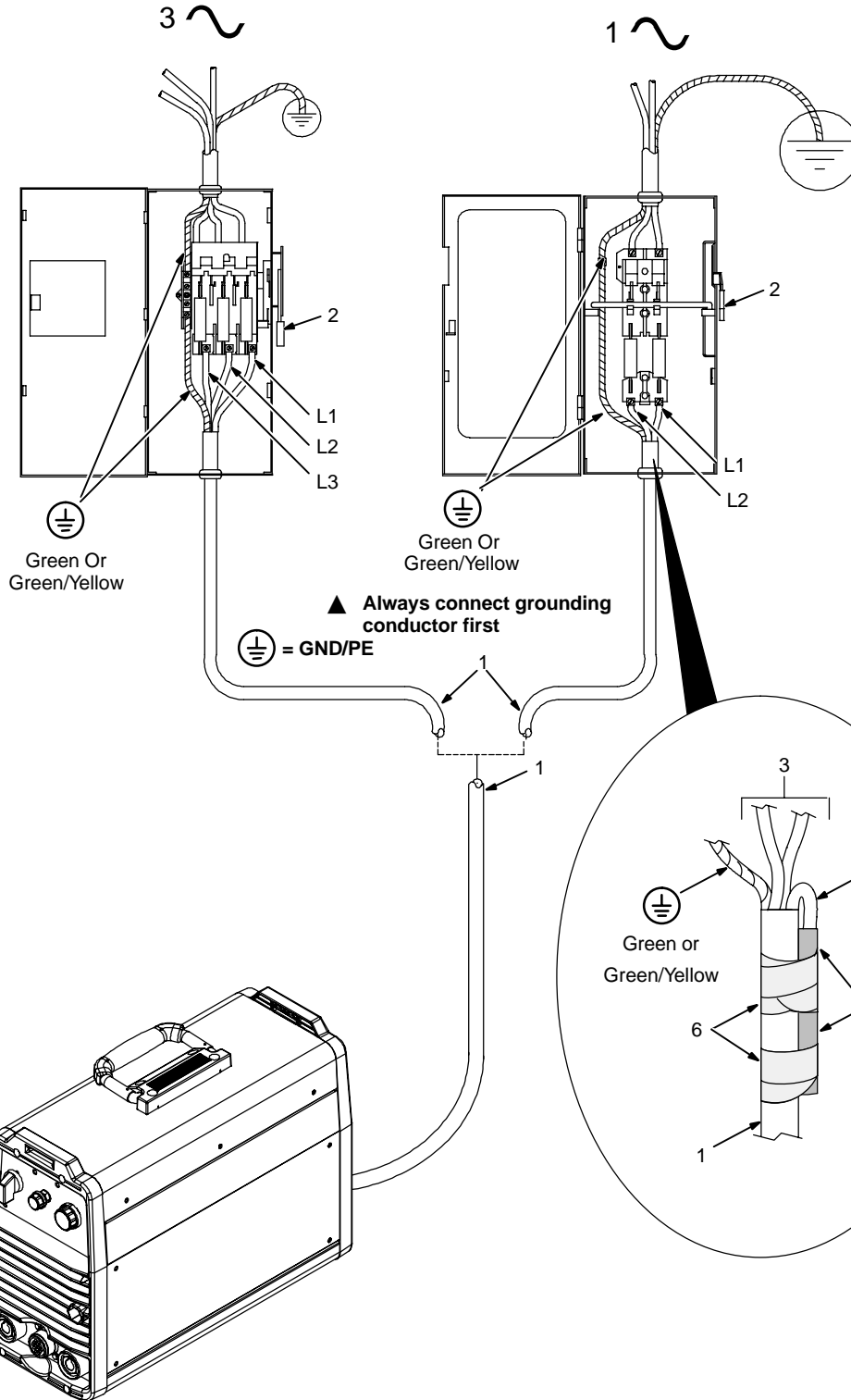

▲ **Disconnect and lockout/tag-out input power before connecting input conductors from unit.**

▲ **Have only qualified persons make this installation.**

See rating label on unit and check input voltage available at site.

1 Input And Grounding Conductors

2 Line Disconnect Device

See Section 2-9.

For three-phase operation:

▲ **Always connect green or green/yellow wire to supply grounding terminal, never to a line terminal.**

Connect black, white, and red wires (L1, L2, L3) to line terminals.

For single-phase operation:

▲ **Always connect green or green/yellow wire to supply grounding terminal, never to a line terminal.**

3 Black And White Input Conductor

4 Red Input Conductor

5 Insulation Sleeving

6 Electrical Tape

Insulate and isolate red conductor as shown.

SECTION 3 – OPERATION

3-1. Controls

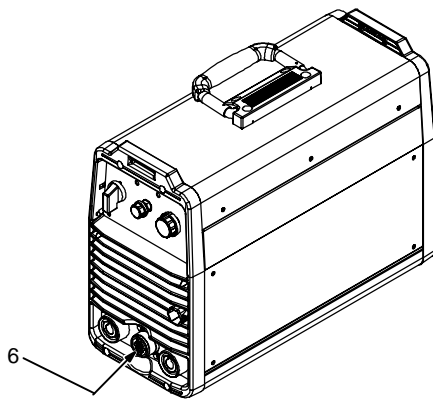
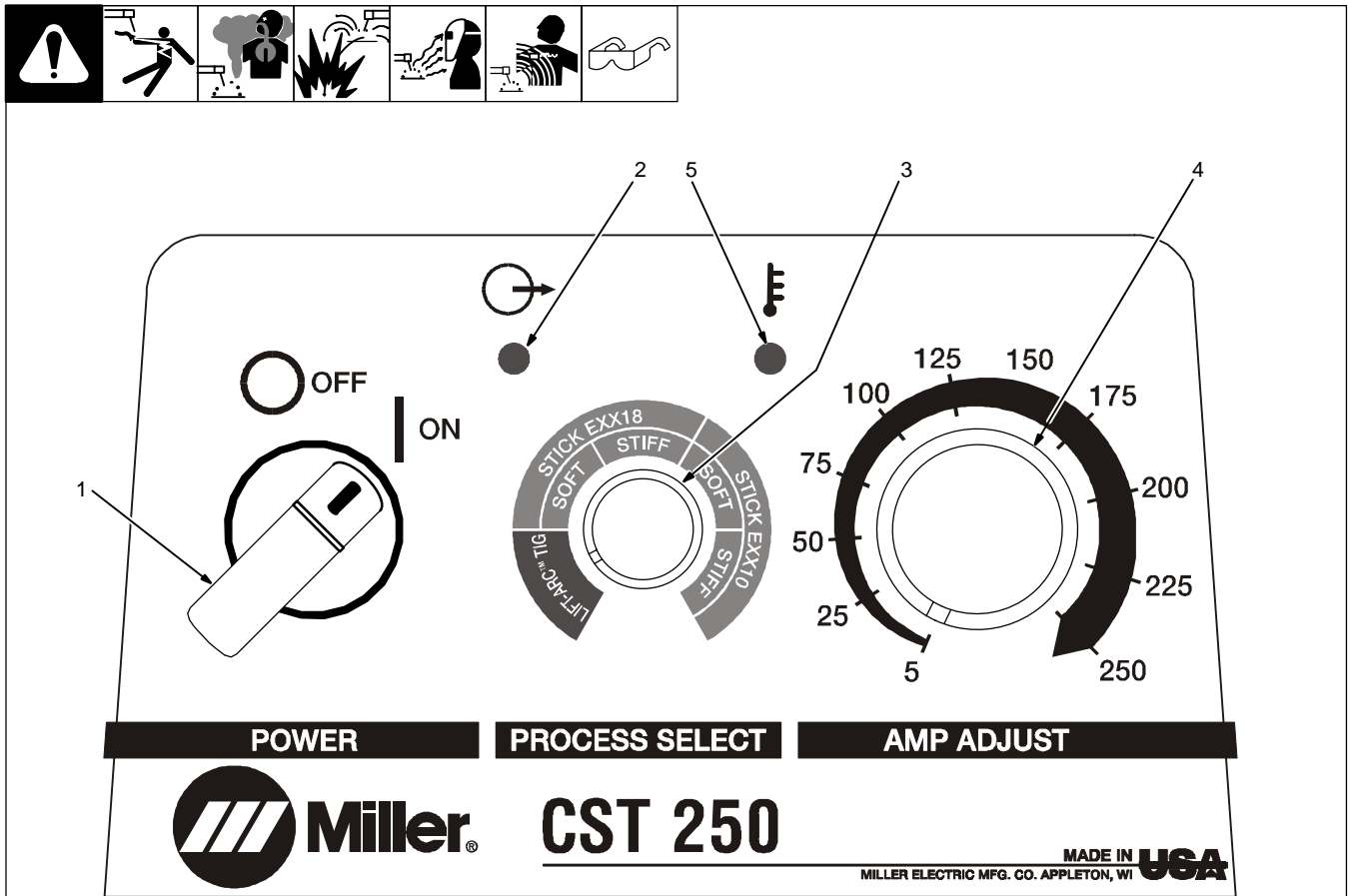

NOTE: Green on nameplate indicates a TIG function, Gray indicates a Stick function.

1 Power Switch

Use switch to turn unit and indicator light On/Off.

2 Output Indicator Light

When unit is first energized this indicator light flashes several times and then illuminates continuously. When unit is shut down, the indicator light flashes several times and the cooling fan will run briefly, then both will turn off completely.

3 Process Control

See Section 3-2.

4 Amperage Control

See Section 3-5.

5 High Temperature Shutdown Light

When unit is first energized this indicator light illuminates for approximately 1 second to provide visual confirmation that the light is functioning properly (see Section 2-2).

6 Remote 14 Receptacle

3-2. Process Select Control

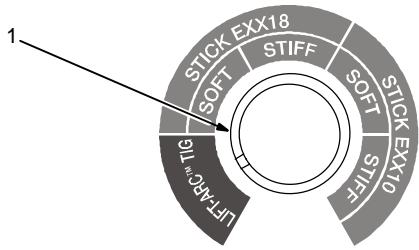

PROCESS SELECT

RECOMMENDED PROCESS SELECTIONS VS ELECTRODE TYPE	
ELECTRODE TYPE	SUGGESTED PROCESS SETTING
EXXX1	EXX10
EXXX2	EXX10
EXXX3	EXX18
EXXX4	EXX18
EXXX5	EXX18
EXXX6	EXX18
EXXX7	EXX18
EXXX8	EXX18
STAINLESS	EXX18

1 Process Select Control

Rotate knob to select desired process.

Lift-Arc™ TIG - Normal open-circuit voltage is not present between the electrode and workpiece. A solid-state contactor does not energize until after the electrode touches the workpiece, preventing overheating, sticking, or contaminating the electrode (see Section 3-4). Make connections according to Section 2-7.

Stick E XX18 Soft - This setting provides a lower dig/arc force setting for smooth weld performance. A stable weld puddle with little arc "snap" gives excellent weld bead appearance with minimal spatter. Make connections according to Section 2-8.

Stick E XX18 Stiff - This setting provides a higher dig/arc force that gives a slightly more fluid weld puddle, more arc "snap", and reduces the potential for electrode sticking at shorter arc lengths. Make connections according to Section 2-8.

Stick E XX10 Soft - This setting provides lower dig/arc force for open root vertical up joints or joints that do not require additional current for fit up inconsistencies. Make connections according to Section 2-8.

Stick E XX10 Stiff - This setting provides a higher dig/arc force for open root vertical down joints where additional current is needed to compensate for tight joint fit up without the need to increase overall welding current. Make connections according to Section 2-8.

3-3. Stick Start Procedure – Scratch Start Technique

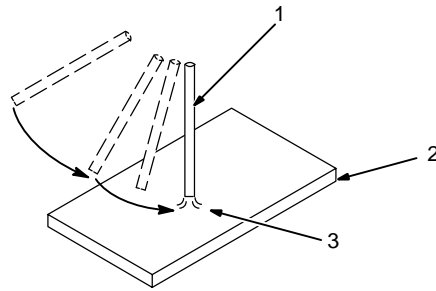

With Stick selected, start arc as follows:

- 1 Electrode
- 2 Workpiece
- 3 Arc

Drag electrode across workpiece like striking a match; lift electrode slightly after touching work. If arc goes out electrode was lifted too high. If electrode sticks to workpiece, use a quick twist to free it.

Normal open-circuit voltage is not present before electrode touches workpiece; only a low sensing voltage is present between electrode and workpiece. This allows electrode to touch workpiece without overheating, sticking, or getting contaminated.

3-4. Lift-Arc™ Start Procedure

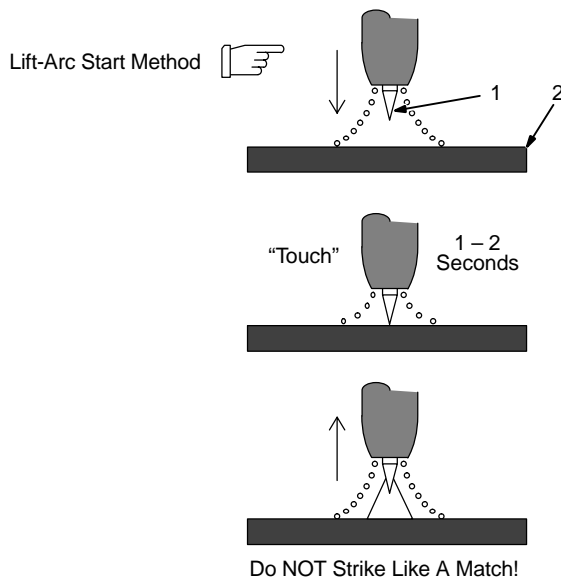

Lift-Arc Start

With Lift-Arc™ selected, start arc as follows:

- 1 TIG Electrode
- 2 Workpiece

Turn gas on. Touch tungsten electrode to workpiece at weld start point. **Hold electrode to workpiece for 1-2 seconds**, and slowly lift electrode. Arc is formed when electrode is lifted.

Normal open-circuit voltage is not present before tungsten electrode touches workpiece; only a low sensing voltage is present between electrode and workpiece. The solid-state output contactor does not energize until after electrode is touching workpiece. This allows electrode to touch workpiece without overheating, sticking, or getting contaminated.

Application:

Lift-Arc is used for the DCEN GTAW process when HF Start method is not permitted, or to replace the scratch method.

3-5. Amperage Control

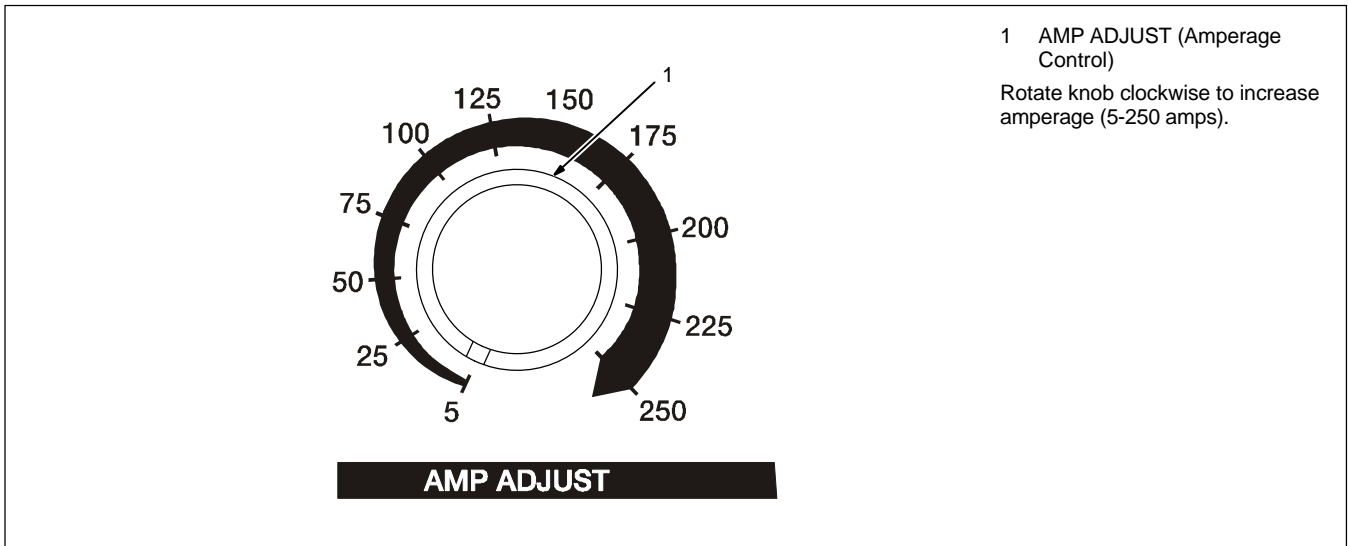

3-6. Remote 14 Receptacle Information

This unit automatically senses when a remote control is connected to the remote 14 receptacle. After connecting a remote control, the unit will automatically adjust output control to a primary/secondary configuration. In this configuration, the AMP ADJUST control on the unit becomes the primary and sets the maximum amperage output of the unit. The remote control becomes the secondary and provides an amperage range adjustment of 0 to 100% based on the AMP ADJUST control setting.

	REMOTE 14	Socket*	Socket Information
	15 VOLTS DC OUTPUT (CONTACTOR)	A	15 volts dc (not functional).
		B	Contact closure to A completes 15 volts dc contactor control circuit (not functional).
	REMOTE OUTPUT CONTROL	C	Output to remote control; 0 to +10 volts dc.
		D	Remote control circuit common.
		E	0 to +10 volts dc input command signal from remote control.
GND	K	Chassis common.	

*The remaining sockets are not used.

3-7. Fan-On-Demand

This unit is equipped with Fan-On-Demand. The fan operates only when necessary to cool internal components. At power down, the fan will operate for a short period of time while the output indicator light is flashing.

3-8. Rack Mounting

This unit is capable of being rack mounted [see rack Owner's Manual, OM-2238 (208 107)].

SECTION 4 – MAINTENANCE AND TROUBLESHOOTING

4-1. Routine Maintenance



▲ Disconnect power before maintaining.

☞ Maintain more often during severe conditions.

	<p>3 Months</p> <p>Replace unreadable labels.</p>	<p>Clean and tighten weld terminals.</p>	<p>Replace Damaged Gas Hose</p>
	<p>3 Months</p> <p>Repair Or Replace Cracked Cables And Cords</p>		
	<p>6 Months</p> <p>▲ Do not remove case when blowing out inside of unit (see Section 4-2).</p> <p>Blow out inside. During heavy service clean monthly.</p>		

4-2. Blowing Out Inside Of Unit



▲ Do not remove case when blowing out inside of unit.

To blow out unit, direct airflow through front and back louvers as shown.

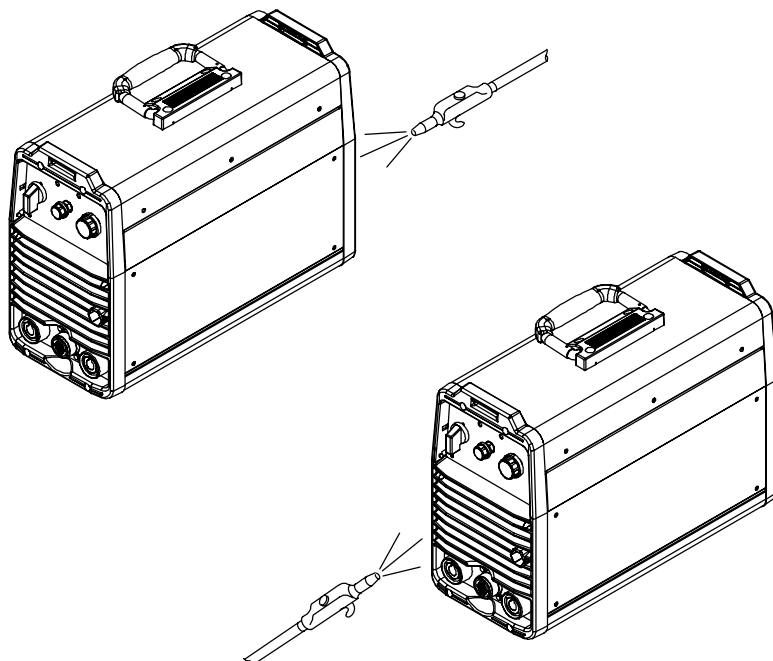

4-3. Troubleshooting

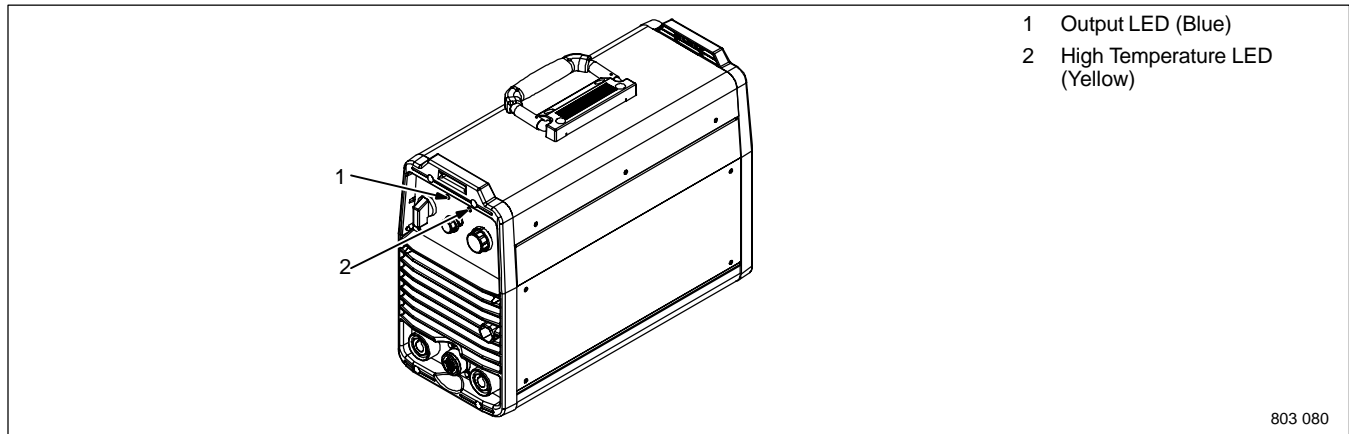

Trouble	Possible Causes	Remedy
No weld output; unit completely inoperative.	Line disconnect switch open.	Place line disconnect switch in On position (see Section 2-12).
	Blown line fuse(s).	Check and replace line fuse(s), if necessary, or reset circuit breaker (see Section 2-12).
	Improper input power connections.	Check for proper input power connections (see Section 2-12).
No weld output. Blue LED flashes continuously, yellow LED off.	Line voltage too high or too low.	Line voltage must be within $\pm 10\%$.
	Unit not linked correctly.	Check line voltage and link unit accordingly.
	Unit needs to be reset.	Cycle power switch off and back on again. If problem is not corrected, contact nearest Factory Authorized Service Agent.
	Voltage in excess of 100 V from another source.	Check and correct any external voltage sources.
Low weld output. Blue LED flashes 2 times repeatedly, yellow LED off.	Short circuit across output studs.	Check and correct any short circuit conditions.
	Single phase rating exceeded (output foldback due to excessive input current).	Reduce output to 200 amperes or less.
No weld output. Blue LED flashes 3 times repeatedly, yellow LED off.	High output VA coupled with a low 230 voltage line (output foldback due to excessive input current).	Check line voltage and weld settings.
	Remote trigger left on.	Turn off remote trigger, wait approximately 5 seconds, and restart operation.
No weld output. Blue LED off, yellow LED on.	Unit overheated.	Allow unit to cool.
No weld output. Blue LED off, yellow LED flashes continuously.	Thermistor failure.	Have Factory Authorized Service Agent check thermistor.
Fan not operating.	Blocked fan blade.	Check and remove anything blocking fan blade movement.
	Fan failure.	Have Factory Authorized Service Agent check fan motor.
Erratic or improper weld output.	Weld cable too small or defective.	Use proper size and type of weld cable (see Section 2-6).
	Dirty or loose connections.	Clean and tighten all weld connections (see Section 2-6).

Trouble	Possible Causes	Remedy
Wandering arc	Improper size tungsten.	Use proper size tungsten (see Section 6).
	Worn or defective tungsten.	Use properly prepared tungsten (see Section 6).
	Shielding gas flow too high.	Reduce shielding gas flow rate (see Section 2-7).
Tungsten electrode oxidizing and not remaining bright after conclusion of weld.	Shielding gas blown away from weld zone.	Shield weld zone from drafts.
	Inadequate postflow time.	Allow adequate postflow time to shield tungsten while it cools, after welding stops.
	Loose or leaking gas fittings.	Check and tighten all gas fittings (see Section 2-7).
	Water in torch.	Refer to torch manual.

SECTION 5 – ELECTRICAL DIAGRAMS

	WARNING
	<ul style="list-style-type: none"> Do not touch live electrical parts. Disconnect input power or stop engine before servicing. Do not operate with covers removed. Have only qualified persons install, use, or service this unit.
ELECTRIC SHOCK HAZARD	

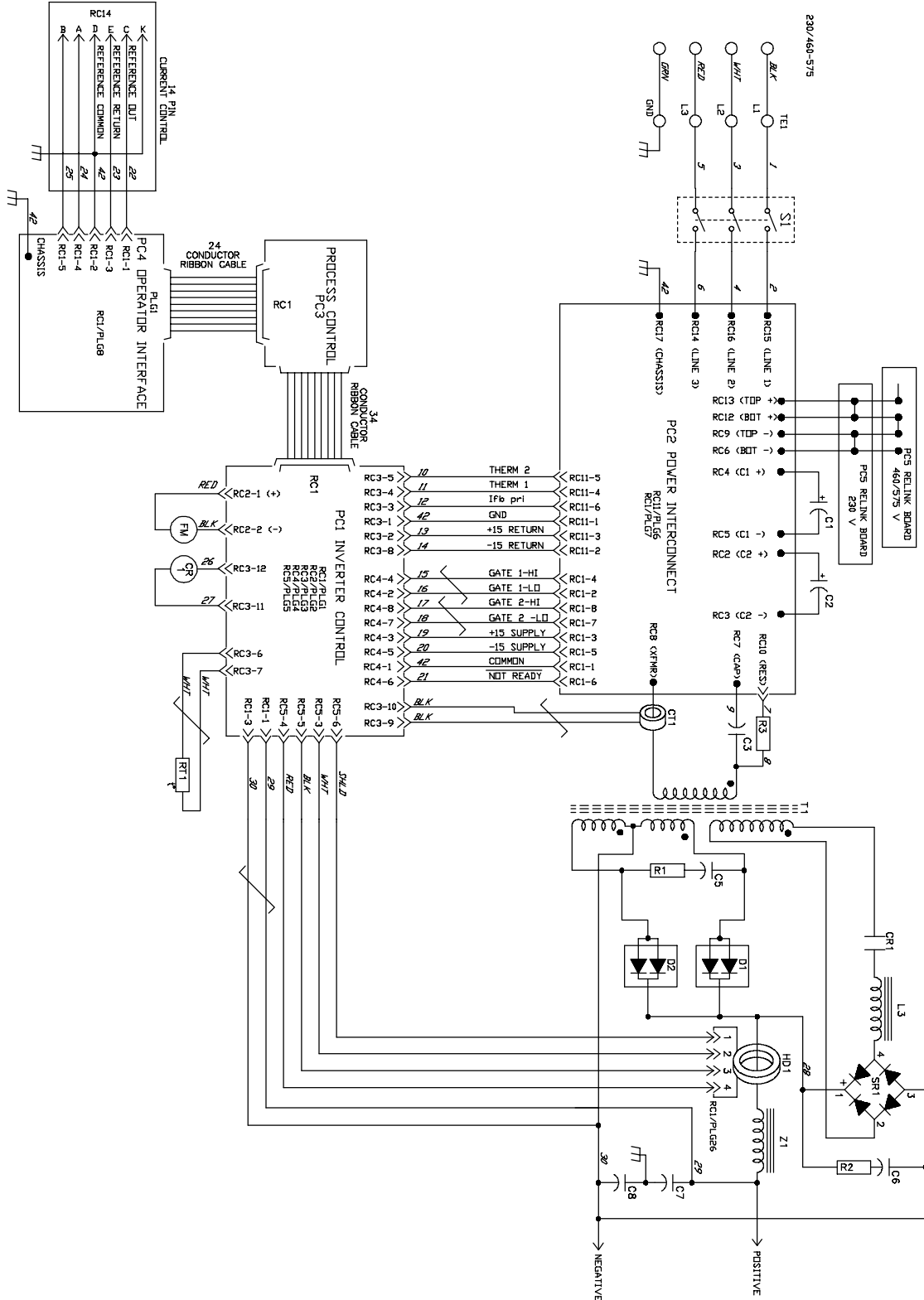

Figure 5-1. Circuit Diagram

SECTION 6 – SELECTING AND PREPARING TUNGSTEN ELECTRODE

gtaw 7/97

NOTE

For additional information, see your distributor for a handbook on the Gas Tungsten Arc Welding (GTAW) process. Wear clean gloves to prevent contamination of tungsten electrode.

6-1. Selecting Tungsten Electrode

Electrode Diameter	Amperage Range - Gas Type♦ - Polarity			
	DC – Argon – Electrode Negative/Straight Polarity	DC – Argon – Electrode Positive/Reverse Polarity	AC – Argon – Using High Frequency	AC – Argon – Balanced Wave Using High Freq.
2% Thorium Alloyed Tungsten (Red Band)				
.010"	Up to 25	*	Up to 20	Up to 15
.020"	15-40	*	15-35	5-20
.040"	25-85	*	20-80	20-60
1/16"	50-160	10-20	50-150	60-120
3/32"	135-235	15-30	130-250	100-180
1/8"	250-400	25-40	225-360	160-250
5/32"	400-500	40-55	300-450	200-320
3/16"	500-750	55-80	400-500	290-390
1/4"	750-1000	80-125	600-800	340-525

♦ Typical argon shielding gas flow rates are 15 to 35 cfh (cubic feet per hour).

*Not Recommended.

The figures listed are intended as a guide and are a composite of recommendations from American Welding Society (AWS) and electrode manufacturers.

6-2. Safety Information About Tungsten

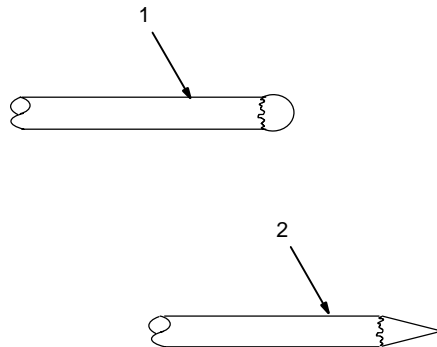

▲ Grinding the tungsten electrode produces dust and flying sparks which can cause injury and start fires. Use local exhaust (forced ventilation) at the grinder or wear an approved respirator. Read MSDS for safety information. Consider using tungsten containing ceria, lanthana, or yttria instead of thoria. Grinding dust from thoriated electrodes contains low-level radioactive material. Properly dispose of grinder dust in an environmentally safe way. Wear proper face, hand, and body protection. Keep flammables away.

- 1 Tungsten Electrode With Balled End
- 2 Pointed Tungsten Electrode

Ref. S-0161

6-3. Preparing Tungsten For AC Or DC Electrode Negative (DCEN) Welding

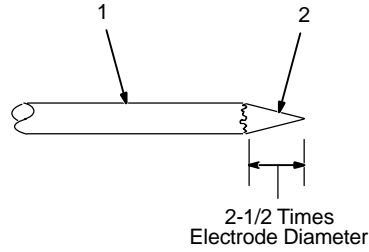

- 1 Tungsten Electrode
- 2 Tapered End

Grind end of tungsten on fine grit, hard abrasive wheel before welding. Do not use wheel for other jobs or tungsten can become contaminated causing lower weld quality.

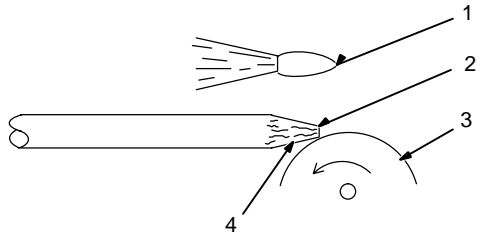

- 1 Stable Arc
- 2 Flat

Diameter of this flat determines amperage capacity.

- 3 Grinding Wheel
- 4 Straight Ground

Grinding wheel should be dedicated to grinding tungsten only.

Ideal Tungsten Preparation – Stable Arc

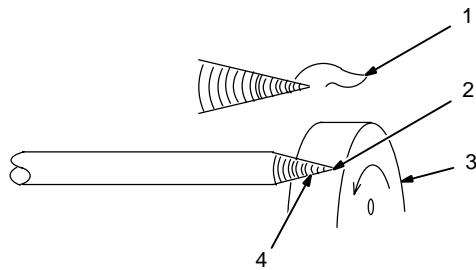

- 1 Arc Wander
- 2 Point
- 3 Grinding Wheel
- 4 Radial Ground

Grinding wheel should be dedicated to grinding tungsten only.

Wrong Tungsten Preparation – Wandering Arc

Ref. S-0161 / Ref. S-0162

SECTION 7 – PARTS LIST

 Hardware is common and not available unless listed.

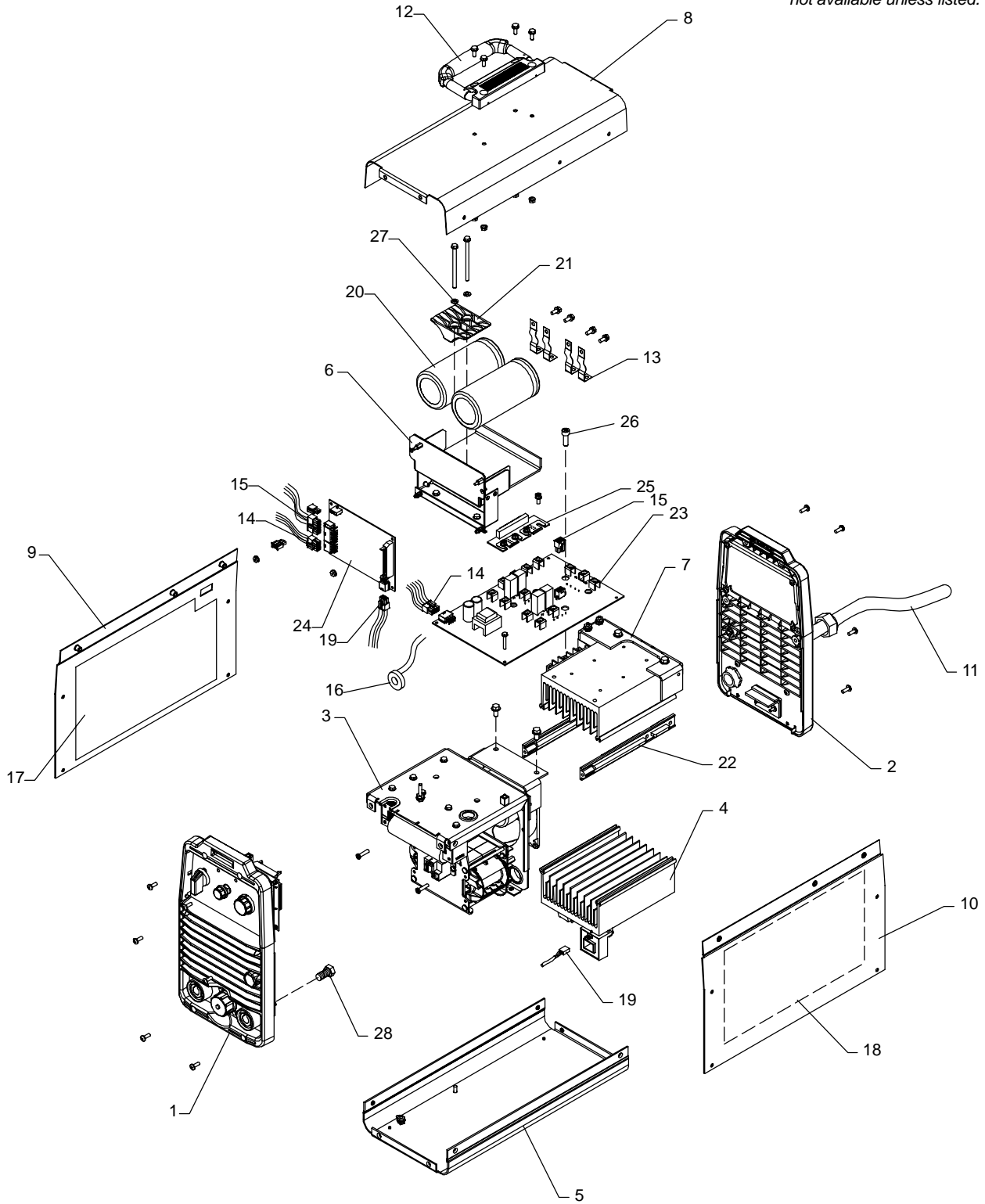

Figure 9-1. Main Assembly

Item No.	Dia. Mkgs.	Part No.	Description	Quantity
----------	------------	----------	-------------	----------

Figure 9-1. Main Assembly

...	1	205758	PANEL,FRONT W/CMPNT	1
...	2	205780	PANEL,REAR W/CMPNT	1
...	3	206037	MAGNETICS SUBASSEMBLY	1
...	4	206090	HEAT SINK ASSEMBLY,OUTPUT DIODE	1
...	5	206039	BASE ASSY,	1
...	6	206093	BRACKET,MTG CAPACITORS	1
...	7	206038	HEAT SINK ASSEMBLY,INPUT	1
...	8	206164	COVER,TOP	1
...	9	206165	PANEL,SIDE LH	1
...	10	206166	PANEL,SIDE RH	1
...	11	207437	CABLE,POWER 10 FT 12GA 4C BLK/RED/WHT/GRNYEL	1
...	12	195585	HANDLE,RUBBERIZED CARRYING	1
...	13	206289	LINK,CONNECTING	4
...	14	206247	PLUGS,W/LEADS	1
...	15	206254	PLUGS,W/LEADS	1
...	16	196231	XFMR,CURRENT SENSING 200/1	1
...	17	206269	INSULATOR,SIDE LH	1
...	18	206270	INSULATOR,SIDE RH	1
...	19	206276	CABLE,LEM W/PLUGS	1
...	20	203912	CAPACITOR,ELCTLT 2400 UF 500 VDC CAN 2.5 DIA	2
...	21	205908	CLAMP,CAPACITOR 2.500 DIA HORIZONTAL MTG NYLON	1
...	22	189777	RAIL, HEAT SINK	2
...		134327	LABEL,WARNING GENERAL PRECAUTIONARY STATIC&WIRE FE	1
...		185835	LABEL,WARNING ELECTRIC SHOCK/EXPLODING PARTS	1
...		182826	LABEL,WARNING ELECTRIC SHOCK POWER CORD	1
...		180994	LABEL,WARNING MATCH INPUT POWER TO VOLTAGE SHOWN	1
...	23	204429	CIRCUIT CARD ASSY,POWER INTERCONNECT	1
...	24	205772	CIRCUIT CARD ASSY,POWER CONTROL	1
...	25	205776	CIRCUIT CARD ASSY,RELINK	1
...	26	196726	SCREW,M 5-.8X 18 PAN HD-PHL STL	6
...	27	207113	WASHER,CONE .205IDX0.394ODX.015T STL	2
...	28	186329	SCREW,M10-1.5X 25 HEX HD-PLN 8.8 PLD	2

+When ordering a component originally displaying a precautionary label, the label should also be ordered.

To maintain the factory original performance of your equipment, use only Manufacturer's Suggested Replacement Parts. Model and serial number required when ordering parts from your local distributor.

☞ Hardware is common and not available unless listed.

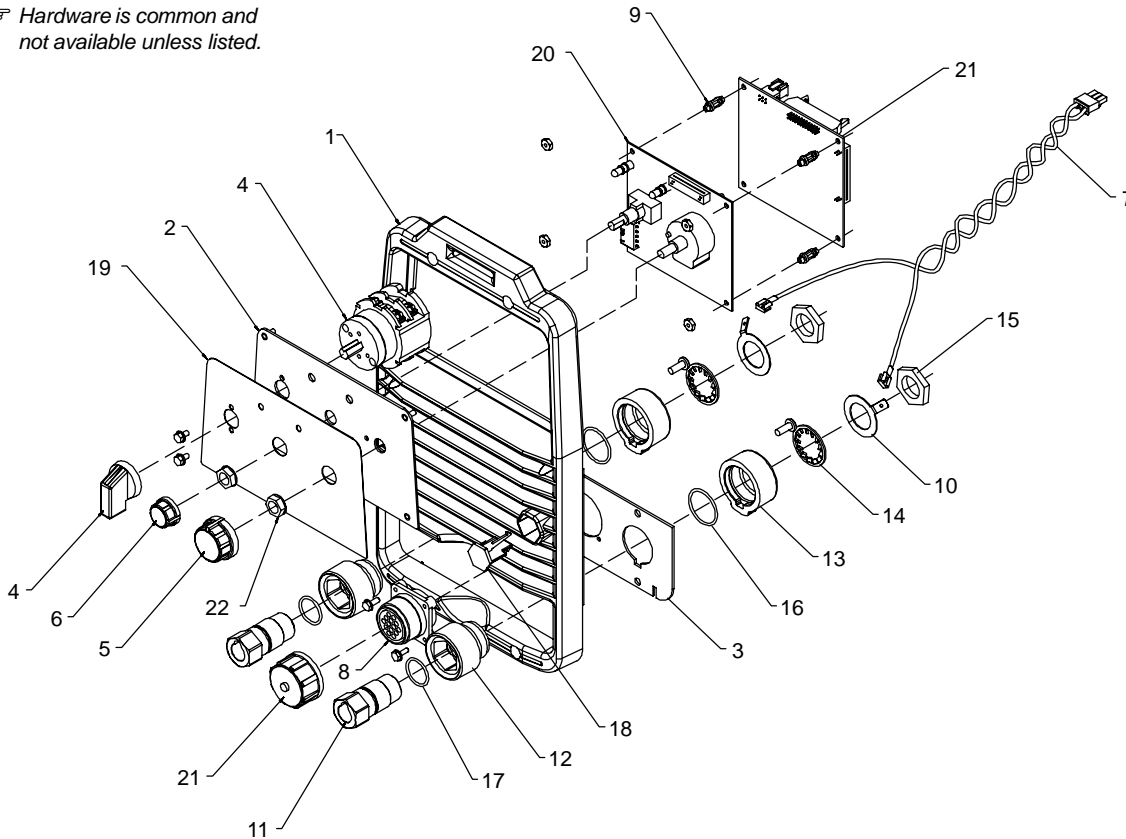

803 158

Figure 9-2. Panel, Front w/Components

Item No.	Dia. Mkgs.	Part No.	Description	Quantity
----------	------------	----------	-------------	----------

Figure 9-2. Panel, Front w/Components

...	1	194242	.. PANEL,FRONT/REAR	1
...	2	205759	.. PANEL,FRONT UPPER	1
...	3	195647	.. PANEL,FRONT LOWER	1
...	4	207165	.. SWITCH,W/LEADS	1
...	5	174991	.. KNOB,POINTER 1.250 DIA X .250 ID W/SPRING CLIP-.21	1
...	6	174992	.. KNOB,POINTER .840 DIA X .250 ID W/SPRING CLIP-.21	1
...	7	207143	.. PLUG,W/LEADS VFB	1
...	8	207144	.. RECEPTACLE W/LEADS&PLUG,(14 PIN)	1
...	9	193115	.. STAND-OFF SUPPORT,PC CARD .156 DIA/.375 LG NYLON	4
...	10	178548	.. TERMINAL,CONNECTOR FRICTION	2
...	11	202553	.. RECEPTACLE,TWIST LOCK(FEMALE)POWER	2
...	12	185712	.. INSULATOR,BULKHEAD FRONT	2
...	13	185713	.. INSULATOR,BULKHEAD REAR	2
...	14	185714	.. WASHER,TOOTH 22MMID X 31.5MMOD 1.310-1MMT INTERN	2
...	15	185717	.. NUT,M20-1.5 1.06HEX .19H BRS LOCKING	2
...	16	185718	.. O-RING, 0.989 ID X 0.070 H	2
...	17	186228	.. O-RING, 0.739 ID X 0.070 H	2
...	18	207253	.. BLANK,HEX HOLE BLACK	1
...	19	204301	.. NAMEPLATE,MILLER CST 250	1
...	20	205764	.. CIRCUIT CARD ASSY,OPERATOR INTERFACE	1
...	21	208057	.. CIRCUIT CARD ASSY,PROCESS CONTROL	1
...	22	178355	.. NUT, 375-32 .54HEX .25H NYL FLANGE .62D	2

To maintain the factory original performance of your equipment, use only Manufacturer's Suggested Replacement Parts. Model and serial number required when ordering parts from your local distributor.

☞ Hardware is common and not available unless listed.

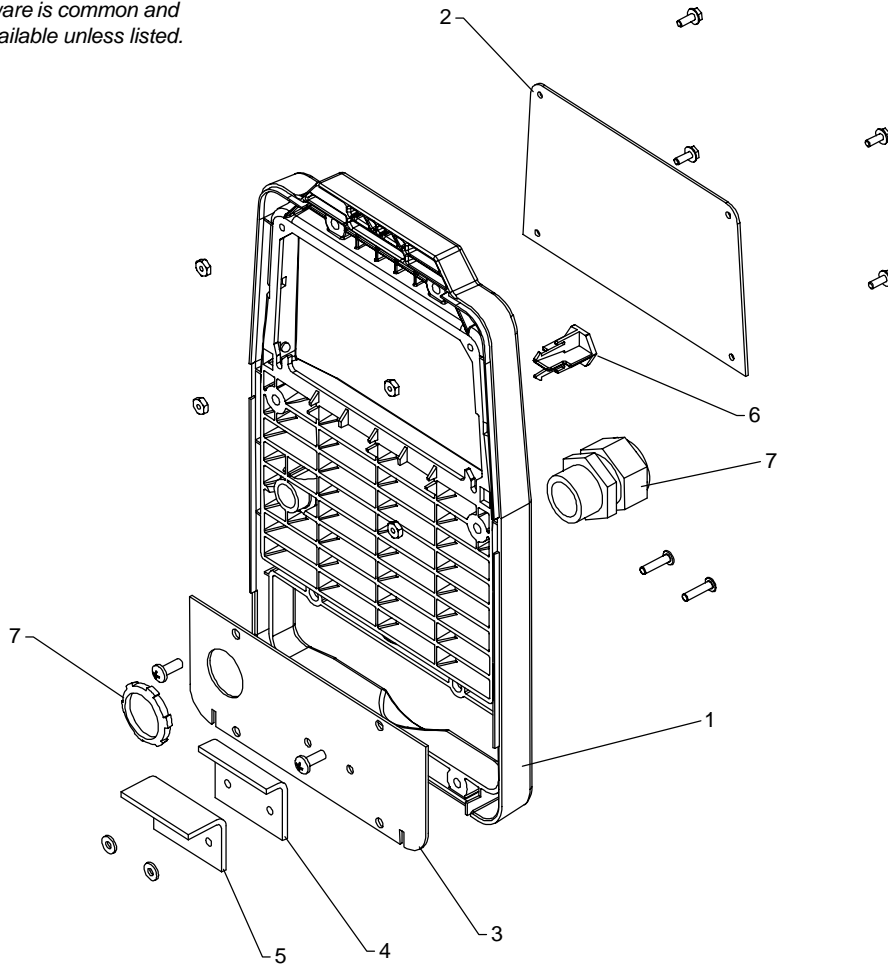

803 161

Figure 9-3. Panel, Rear w/Components

Item No.	Dia. Mkgs.	Part No.	Description	Quantity
Figure 9-3. Panel, Rear w/Components				
...	1	194242	PANEL,FRONT/REAR	1
...	2	206052	PANEL,REAR UPPER	1
...	3	206053	PANEL,REAR LOWER	1
...	4	206055	STOP,HEATSINK	1
...	5	206056	SUPPORT,HEATSINK	1
...	6	207253	BLANK,HEX HOLE BLACK	1
...	7	201155	BUSHING,STRAIN RELIEF .450/.709 ID X1.068 MTG HOLE	1

To maintain the factory original performance of your equipment, use only Manufacturer's Suggested Replacement Parts. Model and serial number required when ordering parts from your local distributor.

 Hardware is common and not available unless listed.

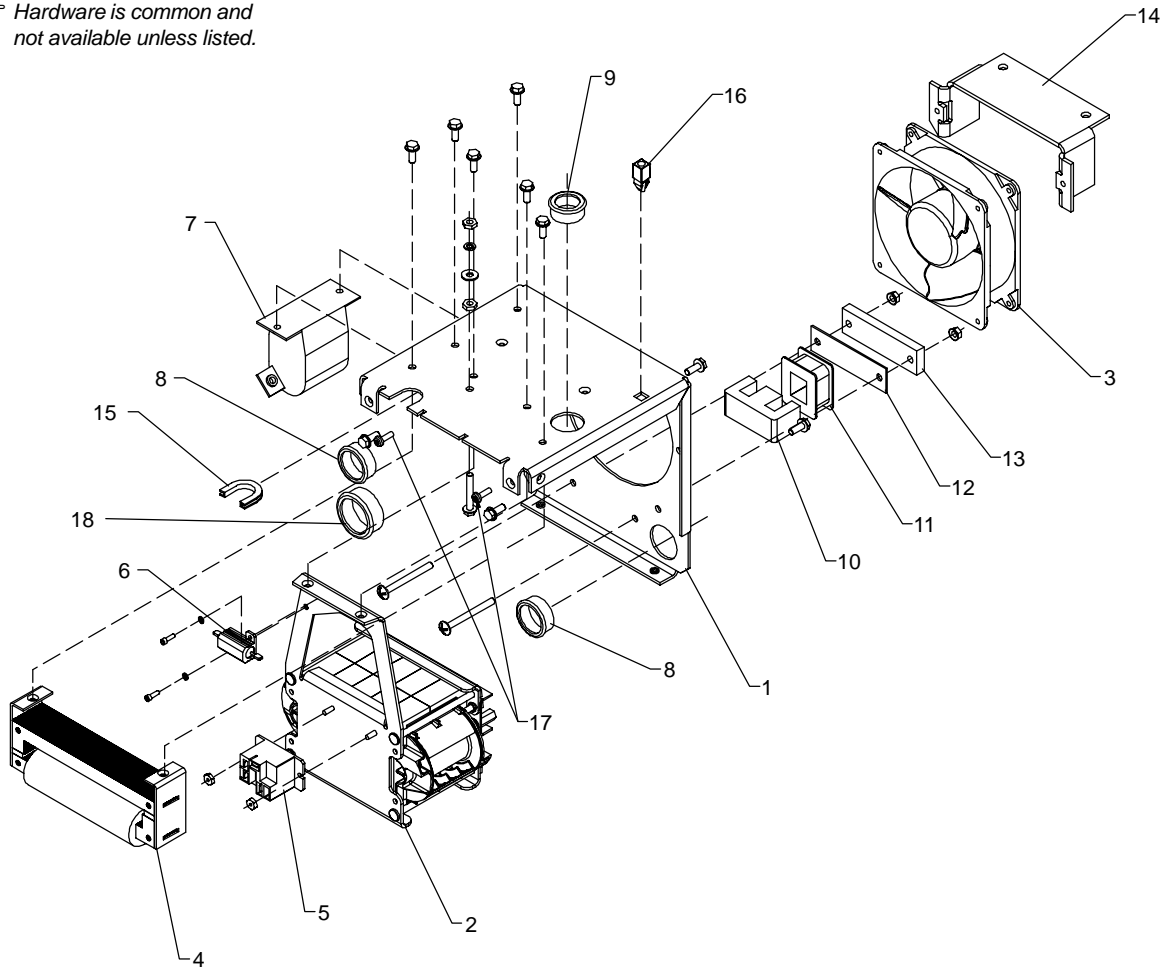

803 163

Figure 9-4. Magnetics Subassembly

Item No.	Dia. Mkgs.	Part No.	Description	Quantity
----------	------------	----------	-------------	----------

Figure 9-4. Magnetics Subassembly

...	1	206063	PANEL,PLENUM	1
...	2	206065	XFMR,HF LITZ/LITZ W/BOOST	1
...	3	196887	FAN,MUFFIN 24VDC 3000 RPM 130 CFM 4.125 MTG HOLES	1
...	4	206064	INDUCTOR,OUTPUT	1
...	5	206258	RELAY,ENCL 24VDC SPST 30A/240VAC 4PIN FLANGE MTG	1
...	6	206281	RESISTOR,W/LEADS	1
...	7	196143	CAPACITOR,POLYP MET FILM 16. UF 400 VAC 10%	1
...	8	057357	BUSHING,SNAP-IN NYL .937 ID X 1.125 MTG HOLE	2
...	9	030170	BUSHING,SNAP-IN NYL .750 ID X 1.000 MTG HOLE	1
...	10	109056	CORE,FERRITE E 2.164 LG X 1.094 HIGH X .826 WIDE	1
...	11	206273	COIL,INDUCTOR (BOOST)	1
...	12	196514	GASKET,INDUCTOR MOUNTING	1
...	13	196512	BRACKET,INDUCTOR MOUNTING	1
...	14	198634	BRACKET,FRONT HEATSINK MTG	1
...	15	607256	GROMMET, CATERPILLAR	0.17
...	16	083147	GROMMET,SCR NO 8/10 PANEL HOLE .312 SQ .500 HIGH	1
...	17	145217	SCREW,K40X 12 PAN HD-PHL STL PLD PT THREAD FORMING	2
...	18	170647	BUSHING,SNAP-IN NYL 1.312 ID X 1.500 MTG HOLE	1

To maintain the factory original performance of your equipment, use only Manufacturer's Suggested Replacement Parts. Model and serial number required when ordering parts from your local distributor.

☞ Hardware is common and not available unless listed.

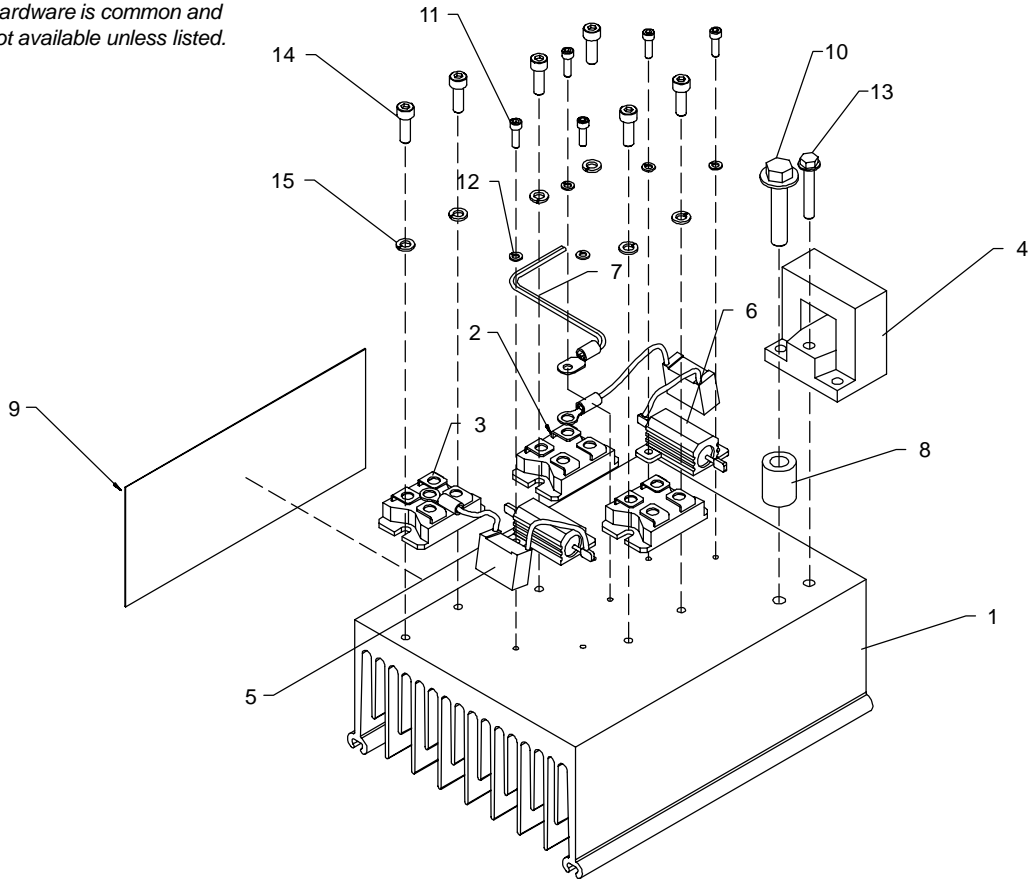

803 159

Figure 9-5. Heat Sink Assembly, Output Diode

Item No.	Dia. Mkgs.	Part No.	Description	Quantity
----------	------------	----------	-------------	----------

Figure 9-5. Heat Sink Assembly, Output Diode

...	1	205916	HEAT SINK,DIODE OUTPUT	1
...	2	206987	DIODE,ULTRA-FAST RECOVERY 120A 400V DUAL SOT-227	2
...	3	199952	DIODE,POWER MODULE 50 AMP 600 V 1PH FAST RECOVE	1
...	4	191941	TRANSDUCER,CURRENT	1
...	5	196510	RESISTOR/CAPACITOR	1
...	6	207384	RESISTOR/CAPACITOR,	1
...	7	199798	THERMISTOR,NTC 30K OHM @ 25 DEG C 18IN LEAD	1
...	8	049611	TUBING,COP .540 OD X .123 WALL X .687	1
...	9	207932	INSULATOR,HEATSINK	1
...	10	108942	SCREW,250-20X1.25 HEXWHD.61D GR5 PLD	1
...	11	156579	SCREW,004-40X .37 SOC HD-HEX STL PLD	5
...	12	156580	WASHER,LOCK .114IDX0.209ODX.025T STL PLD SPLIT #4	5
...	13	602145	SCREW,008-32X .62 HEXWHD.34D STL PLD SLFFMG TAP-RW	1
...	14	070427	SCREW,008-32X .50 SOC HD-HEX GR8 PLD	6
...	15	602200	WASHER,LOCK .168IDX0.293ODX.040T STL PLD SPLIT #8	6

To maintain the factory original performance of your equipment, use only Manufacturer's Suggested Replacement Parts. Model and serial number required when ordering parts from your local distributor.

☞ Hardware is common and not available unless listed.

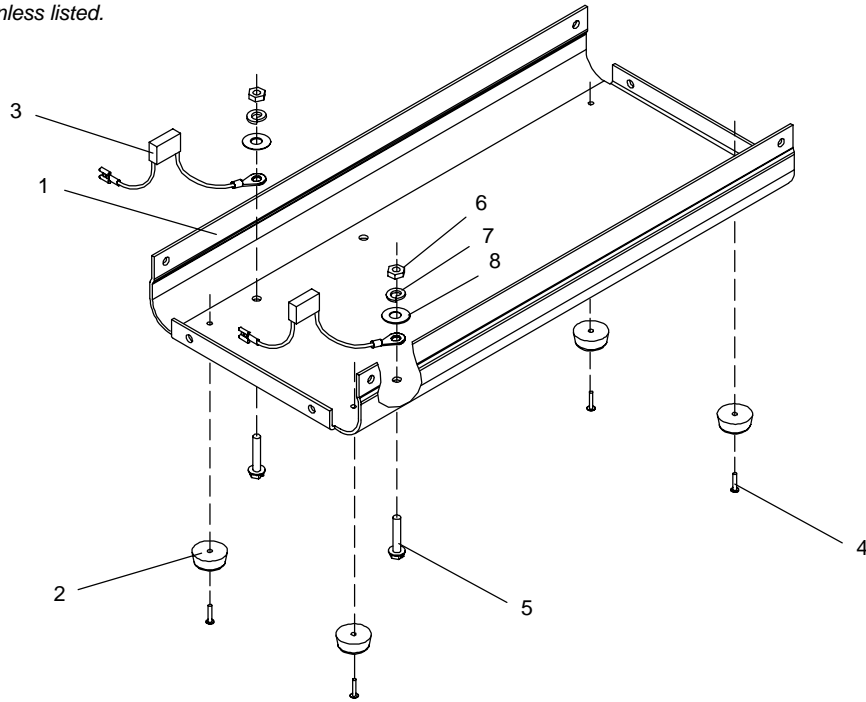

803 160

Figure 9-6. Base Assembly

Item No.	Dia. Mkgs.	Part No.	Description	Quantity
Figure 9-6. Base Assembly				
...	1	206089	.. BASE,	1
...	2	019663	.. MOUNT,NPRN 15/16ODX3/8REC 3/16X3/8	4
...	3	186543	.. CAPACITOR ASSY,	2
...	4	133528	.. RIVET,AL .125 DIA X .188-.250 GRIP BLK BLIND DOME	4
...	5	195666	.. SCREW,010-32X .62 HEXWHD.40D STL PLD SLFFMG TAP-RW	2
...	6	601862	.. NUT, 010-32 .38HEX .13H STL PLD	2
...	7	602203	.. WASHER,LOCK .193IDX0.334ODX.047T STL PLD SPLIT #10	2
...	8	602238	.. WASHER,FLAT .203IDX0.500ODX.048T STL PLD ANSI#10	2

To maintain the factory original performance of your equipment, use only Manufacturer's Suggested Replacement Parts. Model and serial number required when ordering parts from your local distributor.

 Hardware is common and not available unless listed.

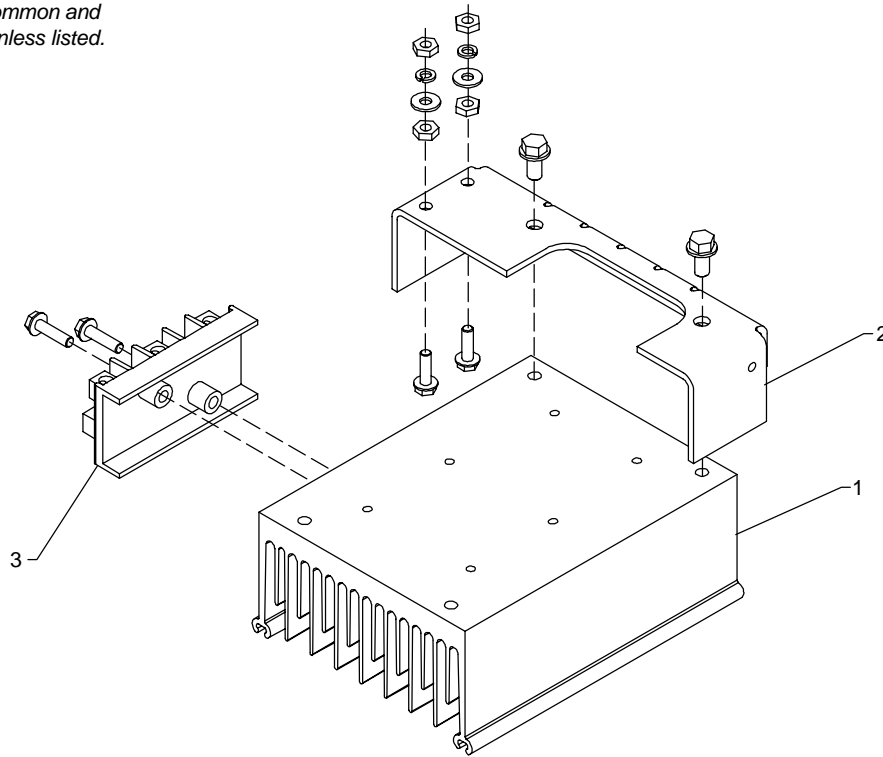

Ref. 803 162

Figure 9-7. Heat Sink Assembly, Input

Item No.	Dia. Mkgs.	Part No.	Description	Quantity
Figure 9-7. Heat Sink Assembly, Input				
... 1	205915	.. HEAT SINK,IGBT/INPUT RECTIFIER MODULE	1
... 2	206091	.. BRACKET,HEATSINK REAR	1
... 3	206328	.. BLOCK,TERM 70 AMP 3 POLE SCREW TERM 4-14 WIRE	1

To maintain the factory original performance of your equipment, use only Manufacturer's Suggested Replacement Parts. Model and serial number required when ordering parts from your local distributor.

TRUE BLUE® WARRANTY

Effective January 1, 2001

(Equipment with a serial number preface of "LB" or newer)

This limited warranty supersedes all previous Miller warranties and is exclusive with no other guarantees or warranties expressed or implied.

Warranty Questions?

Call
1-800-4-A-MILLER
for your local
Miller distributor.

Your distributor also gives
you ...

Service

You always get the fast,
reliable response you
need. Most replacement
parts can be in your
hands in 24 hours.

Support

Need fast answers to the
tough welding questions?
Contact your distributor.
The expertise of the
distributor and Miller is
there to help you, every
step of the way.

LIMITED WARRANTY – Subject to the terms and conditions below, Miller Electric Mfg. Co., Appleton, Wisconsin, warrants to its original retail purchaser that new Miller equipment sold after the effective date of this limited warranty is free of defects in material and workmanship at the time it is shipped by Miller. THIS WARRANTY IS EXPRESSLY IN LIEU OF ALL OTHER WARRANTIES, EXPRESS OR IMPLIED, INCLUDING THE WARRANTIES OF MERCHANTABILITY AND FITNESS.

Within the warranty periods listed below, Miller will repair or replace any warranted parts or components that fail due to such defects in material or workmanship. Miller must be notified in writing within thirty (30) days of such defect or failure, at which time Miller will provide instructions on the warranty claim procedures to be followed.

Miller shall honor warranty claims on warranted equipment listed below in the event of such a failure within the warranty time periods. All warranty time periods start on the date that the equipment was delivered to the original retail purchaser, or one year after the equipment is sent to a North American distributor or eighteen months after the equipment is sent to an International distributor.

1. 5 Years Parts – 3 Years Labor
 - * Original main power rectifiers
 - * Inverters (input and output rectifiers only)
2. 3 Years — Parts and Labor
 - * Transformer/Rectifier Power Sources
 - * Plasma Arc Cutting Power Sources
 - * Semi-Automatic and Automatic Wire Feeders
 - * Inverter Power Supplies
 - * Intelligig
 - * Engine Driven Welding Generators
(NOTE: Engines are warranted separately by the engine manufacturer.)
3. 1 Year — Parts and Labor
 - * DS-2 Wire Feeder
 - * Motor Driven Guns (w/exception of Spoolmate Spoolguns)
 - * Process Controllers
 - * Positioners and Controllers
 - * Automatic Motion Devices
 - * RFCS Foot Controls
 - * Induction Heating Power Sources
 - * Water Coolant Systems
 - * HF Units
 - * Grids
 - * Maxstar 140
 - * Spot Welders
 - * Load Banks
 - * Miller Cyclomatic Equipment
 - * Running Gear/Trailers
 - * Plasma Cutting Torches (except APT & SAF Models)
 - * Field Options
(NOTE: Field options are covered under True Blue® for the remaining warranty period of the product they are installed in, or for a minimum of one year — whichever is greater.)
4. 6 Months — Batteries
5. 90 Days — Parts
 - * MIG Guns/TIG Torches
 - * Induction Heating Coils and Blankets

- * APT, ZIPCUT & PLAZCUT Model Plasma Cutting Torches
- * Remote Controls
- * Accessory Kits
- * Replacement Parts (No labor)
- * Spoolmate Spoolguns
- * Canvas Covers

Miller's True Blue® Limited Warranty shall not apply to:

1. **Consumable components; such as contact tips, cutting nozzles, contactors, brushes, slip rings, relays or parts that fail due to normal wear.**
2. Items furnished by Miller, but manufactured by others, such as engines or trade accessories. These items are covered by the manufacturer's warranty, if any.
3. Equipment that has been modified by any party other than Miller, or equipment that has been improperly installed, improperly operated or misused based upon industry standards, or equipment which has not had reasonable and necessary maintenance, or equipment which has been used for operation outside of the specifications for the equipment.

MILLER PRODUCTS ARE INTENDED FOR PURCHASE AND USE BY COMMERCIAL/INDUSTRIAL USERS AND PERSONS TRAINED AND EXPERIENCED IN THE USE AND MAINTENANCE OF WELDING EQUIPMENT.

In the event of a warranty claim covered by this warranty, the exclusive remedies shall be, at Miller's option: (1) repair; or (2) replacement; or, where authorized in writing by Miller in appropriate cases, (3) the reasonable cost of repair or replacement at an authorized Miller service station; or (4) payment of or credit for the purchase price (less reasonable depreciation based upon actual use) upon return of the goods at customer's risk and expense. Miller's option of repair or replacement will be F.O.B., Factory at Appleton, Wisconsin, or F.O.B. at a Miller authorized service facility as determined by Miller. Therefore no compensation or reimbursement for transportation costs of any kind will be allowed.

TO THE EXTENT PERMITTED BY LAW, THE REMEDIES PROVIDED HEREIN ARE THE SOLE AND EXCLUSIVE REMEDIES. IN NO EVENT SHALL MILLER BE LIABLE FOR DIRECT, INDIRECT, SPECIAL, INCIDENTAL OR CONSEQUENTIAL DAMAGES (INCLUDING LOSS OF PROFIT), WHETHER BASED ON CONTRACT, TORT OR ANY OTHER LEGAL THEORY.

ANY EXPRESS WARRANTY NOT PROVIDED HEREIN AND ANY IMPLIED WARRANTY, GUARANTY OR REPRESENTATION AS TO PERFORMANCE, AND ANY REMEDY FOR BREACH OF CONTRACT TORT OR ANY OTHER LEGAL THEORY WHICH, BUT FOR THIS PROVISION, MIGHT ARISE BY IMPLICATION, OPERATION OF LAW, CUSTOM OF TRADE OR COURSE OF DEALING, INCLUDING ANY IMPLIED WARRANTY OF MERCHANTABILITY OR FITNESS FOR PARTICULAR PURPOSE, WITH RESPECT TO ANY AND ALL EQUIPMENT FURNISHED BY MILLER IS EXCLUDED AND DISCLAIMED BY MILLER.

Some states in the U.S.A. do not allow limitations of how long an implied warranty lasts, or the exclusion of incidental, indirect, special or consequential damages, so the above limitation or exclusion may not apply to you. This warranty provides specific legal rights, and other rights may be available, but may vary from state to state.

In Canada, legislation in some provinces provides for certain additional warranties or remedies other than as stated herein, and to the extent that they may not be waived, the limitations and exclusions set out above may not apply. This Limited Warranty provides specific legal rights, and other rights may be available, but may vary from province to province.





Owner's Record

Please complete and retain with your personal records.

Model Name Serial/Style Number

Purchase Date (Date which equipment was delivered to original customer.)

Distributor

Address

City

State Zip



For Service

Call 1-800-4-A-Miller or see our website at www.MillerWelds.com to locate a DISTRIBUTOR or SERVICE AGENCY near you.

Always provide Model Name and Serial/Style Number.

-
- | | |
|-------------------------------|------------------------------------------------------------------------------------------------------------------------------------------------------------------------------------------------------------------------------------------------------------------------------------------------------------------------------------------------------------------------------------|
| Contact your Distributor for: | <ul style="list-style-type: none"> Welding Supplies and Consumables Options and Accessories Personal Safety Equipment Service and Repair Replacement Parts Training (Schools, Videos, Books) Technical Manuals (Servicing Information and Parts) Circuit Diagrams Welding Process Handbooks |
|-------------------------------|------------------------------------------------------------------------------------------------------------------------------------------------------------------------------------------------------------------------------------------------------------------------------------------------------------------------------------------------------------------------------------|

Contact the Delivering Carrier for: File a claim for loss or damage during shipment.

For assistance in filing or settling claims, contact your distributor and/or equipment manufacturer's Transportation Department.

Miller Electric Mfg. Co.

An Illinois Tool Works Company
1635 West Spencer Street
Appleton, WI 54914 USA

International Headquarters—USA

USA Phone: 920-735-4505 Auto-Attended
USA & Canada FAX: 920-735-4134
International FAX: 920-735-4125

European Headquarters – United Kingdom

Phone: 44 (0) 1204-593493
FAX: 44 (0) 1204-598066

www.MillerWelds.com

