



OM-233 865Q

2015-07

Processes



Multiprocess Welding

Description



Arc Welding Power Source

XMT[®] 350 CC/CV Auto-Line[™] CE

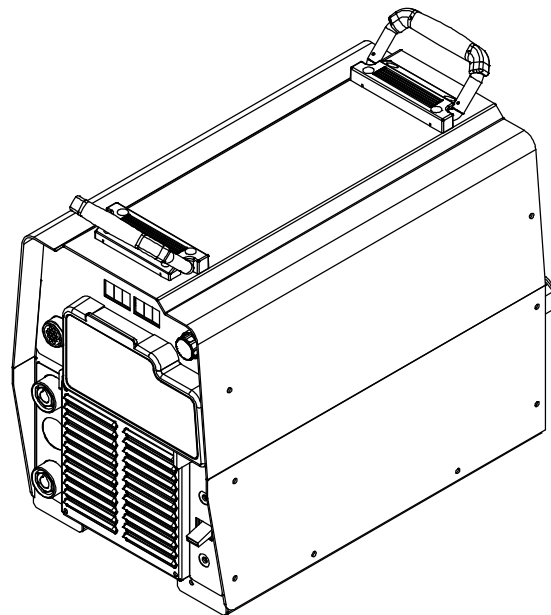

OWNER'S MANUAL



Visit our website at

www.MillerWelds.com

File: MULTIPROCESS



From Miller to You

Thank you and congratulations on choosing Miller. Now you can get the job done and get it done right. We know you don't have time to do it any other way.

That's why when Niels Miller first started building arc welders in 1929, he made sure his products offered long-lasting value and superior quality. Like you, his customers couldn't afford anything less. Miller products had to be more than the best they could be. They had to be the best you could buy.

Today, the people that build and sell Miller products continue the tradition. They're just as committed to providing equipment and service that meets the high standards of quality and value established in 1929.

This Owner's Manual is designed to help you get the most out of your Miller products. Please take time to read the Safety precautions. They will help you protect yourself against potential hazards on the worksite. We've made installation and operation quick and easy. With Miller you can count on years of reliable service with proper maintenance. And if for some reason the unit needs repair, there's a Troubleshooting section that will help you figure out what the problem is. The parts list will then help you to decide which exact part you may need to fix the problem. Warranty and service information for your particular model are also provided.



Miller Electric manufactures a full line of welders and welding related equipment. For information on other quality Miller products, contact your local Miller distributor to receive the latest full line catalog or individual catalog sheets.



Working as hard as you do – every power source from Miller is backed by the most hassle-free warranty in the business.



TABLE OF CONTENTS

SECTION 1 – SAFETY PRECAUTIONS - READ BEFORE USING	1
1-1. Symbol Usage	1
1-2. Arc Welding Hazards	1
1-3. Additional Symbols For Installation, Operation, And Maintenance	3
1-4. California Proposition 65 Warnings	4
1-5. Principal Safety Standards	4
1-6. EMF Information	4
SECTION 2 – DEFINITIONS	5
2-1. Additional Safety Symbols And Definitions	5
2-2. Miscellaneous Symbols And Definitions	7
SECTION 3 – SPECIFICATIONS	8
3-1. Serial Number And Rating Label Location	8
3-2. Unit Specifications	8
3-3. Dimensions And Weight	8
3-4. Environmental Specifications	8
3-5. Duty Cycle And Overheating	10
3-6. Volt-Ampere Curves	11
SECTION 4 – INSTALLATION	12
4-1. Selecting A Location	12
4-2. Selecting Cable Sizes*	13
4-3. Weld Output Terminals	13
4-4. Remote 14 Receptacle Information	14
4-5. 115 Volts AC Duplex Receptacle And Supplementary Protectors	14
4-6. Optional Gas Valve Operation And Shielding Gas Connection	15
4-7. Electrical Service Guide	16
4-8. Connecting 3-Phase Input Power	18
SECTION 5 – OPERATION	20
5-1. Front Panel Controls	20
5-2. Meter Functions	21
5-3. Mode Switch Settings	21
5-4. Lift-Arc Trigger Hold TIG	22
5-5. Stick Start Procedure	22
SECTION 6 – MAINTENANCE & TROUBLESHOOTING	23
6-1. Routine Maintenance	23
6-2. Blowing Out Inside Of Unit	23
6-3. Voltmeter/Ammeter Help Displays	24
6-4. Troubleshooting	24
SECTION 7 – ELECTRICAL DIAGRAM	26
SECTION 8 – PARTS LIST	28
WARRANTY	



DECLARATION OF CONFORMITY

for European Community (CE marked) products.

ITW Welding Italy S.r.l Via Privata Iseo 6/E, 20098 San Giuliano M.se, (MI) Italy declares that the product(s) identified in this declaration conform to the essential requirements and provisions of the stated Council Directive(s) and Standard(s).

Product/Apparatus Identification:

Product	Stock Number
XMT 350 CC/CV AUTOLINE, CE	907371

Council Directives:

- 2006/95/EC Low Voltage
- 2004/108/EC Electromagnetic Compatibility
- 2011/65/EU Restriction of the use of certain hazardous substances in electrical and electronic equipment

Standards:

- IEC 60974-1:2012 Arc Welding Equipment - Part 1: Welding Power Sources
- IEC 60974-10:2007 Arc Welding Equipment - Part 10: Electromagnetic Compatibility Requirements

EU Signatory:

July 17th, 2015

Massimiliano Lavarini

Date of Declaration

ITW WELDING ITALY PRODUCTION MANAGER

956 172 219

SECTION 1 – SAFETY PRECAUTIONS - READ BEFORE USING

som 2013-09

 Protect yourself and others from injury — read, follow, and save these important safety precautions and operating instructions.

1-1. Symbol Usage



DANGER! – Indicates a hazardous situation which, if not avoided, will result in death or serious injury. The possible hazards are shown in the adjoining symbols or explained in the text.



Indicates a hazardous situation which, if not avoided, could result in death or serious injury. The possible hazards are shown in the adjoining symbols or explained in the text.

NOTICE – Indicates statements not related to personal injury.

1-2. Arc Welding Hazards



The symbols shown below are used throughout this manual to call attention to and identify possible hazards. When you see the symbol, watch out, and follow the related instructions to avoid the hazard. The safety information given below is only a summary of the more complete safety information found in the Safety Standards listed in Section 1-5. Read and follow all Safety Standards.



Only qualified persons should install, operate, maintain, and repair this unit.



During operation, keep everybody, especially children, away.



ELECTRIC SHOCK can kill.

Touching live electrical parts can cause fatal shocks or severe burns. The electrode and work circuit is electrically live whenever the output is on. The input power circuit and machine internal circuits are also live when power is on. In semiautomatic or automatic wire welding, the wire, wire reel, drive roll housing, and all metal parts touching the welding wire are electrically live. Incorrectly installed or improperly grounded equipment is a hazard.

- Do not touch live electrical parts.

- Wear dry, hole-free insulating gloves and body protection.
- Insulate yourself from work and ground using dry insulating mats or covers big enough to prevent any physical contact with the work or ground.
- Do not use AC output in damp areas, if movement is confined, or if there is a danger of falling.
- Use AC output ONLY if required for the welding process.
- If AC output is required, use remote output control if present on unit.
- Additional safety precautions are required when any of the following electrically hazardous conditions are present: in damp locations or while wearing wet clothing; on metal structures such as floors, gratings, or scaffolds; when in cramped positions such as sitting, kneeling, or lying; or when there is a high risk of unavoidable or accidental contact with the workpiece or ground. For these conditions, use the following equipment in order presented: 1) a semiautomatic DC constant voltage (wire) welder, 2) a DC manual (stick) welder, or 3) an AC welder with reduced open-circuit voltage. In most situations, use of a DC, constant voltage wire welder is recommended. And, do not work alone!
- Disconnect input power or stop engine before installing or servicing this equipment. Lockout/tagout input power according to OSHA 29 CFR 1910.147 (see Safety Standards).
- Properly install, ground, and operate this equipment according to its Owner's Manual and national, state, and local codes.
- Always verify the supply ground – check and be sure that input power cord ground wire is properly connected to ground terminal in

 Indicates special instructions.



This group of symbols means Warning! Watch Out! ELECTRIC SHOCK, MOVING PARTS, and HOT PARTS hazards. Consult symbols and related instructions below for necessary actions to avoid the hazards.

disconnect box or that cord plug is connected to a properly grounded receptacle outlet.

- When making input connections, attach proper grounding conductor first – double-check connections.
- Keep cords dry, free of oil and grease, and protected from hot metal and sparks.
- Frequently inspect input power cord and ground conductor for damage or bare wiring – replace immediately if damaged – bare wiring can kill.
- Turn off all equipment when not in use.
- Do not use worn, damaged, undersized, or repaired cables.
- Do not drape cables over your body.
- If earth grounding of the workpiece is required, ground it directly with a separate cable.
- Do not touch electrode if you are in contact with the work, ground, or another electrode from a different machine.
- Do not touch electrode holders connected to two welding machines at the same time since double open-circuit voltage will be present.
- Use only well-maintained equipment. Repair or replace damaged parts at once. Maintain unit according to manual.
- Wear a safety harness if working above floor level.
- Keep all panels and covers securely in place.
- Clamp work cable with good metal-to-metal contact to workpiece or worktable as near the weld as practical.
- Insulate work clamp when not connected to workpiece to prevent contact with any metal object.
- Do not connect more than one electrode or work cable to any single weld output terminal. Disconnect cable for process not in use.
- Use GFCI protection when operating auxiliary equipment in damp or wet locations.

SIGNIFICANT DC VOLTAGE exists in inverter welding power sources AFTER removal of input power.

- Turn Off inverter, disconnect input power, and discharge input capacitors according to instructions in Maintenance Section before touching any parts.



HOT PARTS can burn.

- Do not touch hot parts bare handed.
- Allow cooling period before working on equipment.
- To handle hot parts, use proper tools and/or wear heavy, insulated welding gloves and clothing to prevent burns.



FUMES AND GASES can be hazardous.

Welding produces fumes and gases. Breathing these fumes and gases can be hazardous to your health.

- Keep your head out of the fumes. Do not breathe the fumes.
- If inside, ventilate the area and/or use local forced ventilation at the arc to remove welding fumes and gases. The recommended way to determine adequate ventilation is to sample for the composition and quantity of fumes and gases to which personnel are exposed.
- If ventilation is poor, wear an approved air-supplied respirator.
- Read and understand the Safety Data Sheets (SDSs) and the manufacturer's instructions for adhesives, coatings, cleaners, consumables, coolants, degreasers, fluxes, and metals.
- Work in a confined space only if it is well ventilated, or while wearing an air-supplied respirator. Always have a trained watch-person nearby. Welding fumes and gases can displace air and lower the oxygen level causing injury or death. Be sure the breathing air is safe.
- Do not weld in locations near degreasing, cleaning, or spraying operations. The heat and rays of the arc can react with vapors to form highly toxic and irritating gases.
- Do not weld on coated metals, such as galvanized, lead, or cadmium plated steel, unless the coating is removed from the weld area, the area is well ventilated, and while wearing an air-supplied respirator. The coatings and any metals containing these elements can give off toxic fumes if welded.



ARC RAYS can burn eyes and skin.

Arc rays from the welding process produce intense visible and invisible (ultraviolet and infrared) rays that can burn eyes and skin. Sparks fly off from the weld.

- Wear an approved welding helmet fitted with a proper shade of filter lenses to protect your face and eyes from arc rays and sparks when welding or watching (see ANSI Z49.1 and Z87.1 listed in Safety Standards).
- Wear approved safety glasses with side shields under your helmet.
- Use protective screens or barriers to protect others from flash, glare and sparks; warn others not to watch the arc.
- Wear body protection made from durable, flame-resistant material (leather, heavy cotton, wool). Body protection includes oil-free clothing such as leather gloves, heavy shirt, cuffless trousers, high shoes, and a cap.



WELDING can cause fire or explosion.

Welding on closed containers, such as tanks, drums, or pipes, can cause them to blow up. Sparks can fly off from the welding arc. The flying sparks, hot workpiece, and hot equipment can cause fires and burns. Accidental contact of electrode to metal objects can cause sparks, explosion, overheating, or fire. Check and be sure the area is safe before doing any welding.

- Remove all flammables within 35 ft (10.7 m) of the welding arc. If this is not possible, tightly cover them with approved covers.
- Do not weld where flying sparks can strike flammable material.
- Protect yourself and others from flying sparks and hot metal.
- Be alert that welding sparks and hot materials from welding can easily go through small cracks and openings to adjacent areas.
- Watch for fire, and keep a fire extinguisher nearby.
- Be aware that welding on a ceiling, floor, bulkhead, or partition can cause fire on the hidden side.
- Do not weld on containers that have held combustibles, or on closed containers such as tanks, drums, or pipes unless they are properly prepared according to AWS F4.1 and AWS A6.0 (see Safety Standards).
- Do not weld where the atmosphere may contain flammable dust, gas, or liquid vapors (such as gasoline).
- Connect work cable to the work as close to the welding area as practical to prevent welding current from traveling long, possibly unknown paths and causing electric shock, sparks, and fire hazards.
- Do not use welder to thaw frozen pipes.

- Remove stick electrode from holder or cut off welding wire at contact tip when not in use.
- Wear body protection made from durable, flame-resistant material (leather, heavy cotton, wool). Body protection includes oil-free clothing such as leather gloves, heavy shirt, cuffless trousers, high shoes, and a cap.
- Remove any combustibles, such as a butane lighter or matches, from your person before doing any welding.
- After completion of work, inspect area to ensure it is free of sparks, glowing embers, and flames.
- Use only correct fuses or circuit breakers. Do not oversize or bypass them.
- Follow requirements in OSHA 1910.252 (a) (2) (iv) and NFPA 51B for hot work and have a fire watcher and extinguisher nearby.
- Read and understand the Safety Data Sheets (SDSs) and the manufacturer's instructions for adhesives, coatings, cleaners, consumables, coolants, degreasers, fluxes, and metals.

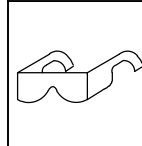

FLYING METAL or DIRT can injure eyes.

- Welding, chipping, wire brushing, and grinding cause sparks and flying metal. As welds cool, they can throw off slag.
- Wear approved safety glasses with side shields even under your welding helmet.



BUILDUP OF GAS can injure or kill.

- Shut off compressed gas supply when not in use.
- Always ventilate confined spaces or use approved air-supplied respirator.

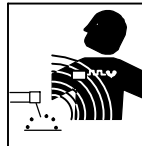

ELECTRIC AND MAGNETIC FIELDS (EMF) can affect Implanted Medical Devices.

- Wearers of Pacemakers and other Implanted Medical Devices should keep away.
- Implanted Medical Device wearers should consult their doctor and the device manufacturer before going near arc welding, spot welding, gouging, plasma arc cutting, or induction heating operations.

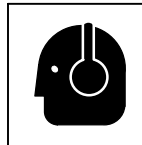

NOISE can damage hearing.

Noise from some processes or equipment can damage hearing.

- Wear approved ear protection if noise level is high.

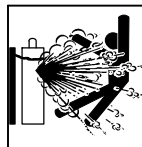

CYLINDERS can explode if damaged.

Compressed gas cylinders contain gas under high pressure. If damaged, a cylinder can explode. Since gas cylinders are normally part of the welding process, be sure to treat them carefully.

- Protect compressed gas cylinders from excessive heat, mechanical shocks, physical damage, slag, open flames, sparks, and arcs.
- Install cylinders in an upright position by securing to a stationary support or cylinder rack to prevent falling or tipping.
- Keep cylinders away from any welding or other electrical circuits.
- Never drape a welding torch over a gas cylinder.
- Never allow a welding electrode to touch any cylinder.
- Never weld on a pressurized cylinder – explosion will result.
- Use only correct compressed gas cylinders, regulators, hoses, and fittings designed for the specific application; maintain them and associated parts in good condition.
- Turn face away from valve outlet when opening cylinder valve. Do not stand in front of or behind the regulator when opening the valve.
- Keep protective cap in place over valve except when cylinder is in use or connected for use.
- Use the right equipment, correct procedures, and sufficient number of persons to lift and move cylinders.
- Read and follow instructions on compressed gas cylinders, associated equipment, and Compressed Gas Association (CGA) publication P-1 listed in Safety Standards.

1-3. Additional Symbols For Installation, Operation, And Maintenance



FIRE OR EXPLOSION hazard.

- Do not install or place unit on, over, or near combustible surfaces.
- Do not install unit near flammables.
- Do not overload building wiring – be sure power supply system is properly sized, rated, and protected to handle this unit.



FALLING EQUIPMENT can injure.

- Use lifting eye to lift unit only, NOT running gear, gas cylinders, or any other accessories.
- Use equipment of adequate capacity to lift and support unit.
- If using lift forks to move unit, be sure forks are long enough to extend beyond opposite side of unit.
- Keep equipment (cables and cords) away from moving vehicles when working from an aerial location.
- Follow the guidelines in the Applications Manual for the Revised NIOSH Lifting Equation (Publication No. 94–110) when manually lifting heavy parts or equipment.



OVERUSE can cause OVERHEATING

- Allow cooling period; follow rated duty cycle.
- Reduce current or reduce duty cycle before starting to weld again.
- Do not block or filter airflow to unit.

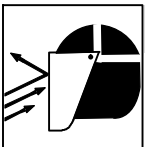

FLYING SPARKS can injure.

- Wear a face shield to protect eyes and face.
- Shape tungsten electrode only on grinder with proper guards in a safe location wearing proper face, hand, and body protection.
- Sparks can cause fires — keep flammables away.

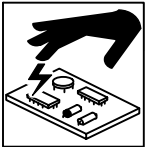

STATIC (ESD) can damage PC boards.

- Put on grounded wrist strap BEFORE handling boards or parts.
- Use proper static-proof bags and boxes to store, move, or ship PC boards.



MOVING PARTS can injure.

- Keep away from moving parts.
- Keep away from pinch points such as drive rolls.



WELDING WIRE can injure.

- Do not press gun trigger until instructed to do so.
- Do not point gun toward any part of the body, other people, or any metal when threading welding wire.



BATTERY EXPLOSION can injure.

- Do not use welder to charge batteries or jump start vehicles unless it has a battery charging feature designed for this purpose.



MOVING PARTS can injure.

- Keep away from moving parts such as fans.
- Keep all doors, panels, covers, and guards closed and securely in place.
- Have only qualified persons remove doors, panels, covers, or guards for maintenance and troubleshooting as necessary.
- Reinstall doors, panels, covers, or guards when maintenance is finished and before reconnecting input power.

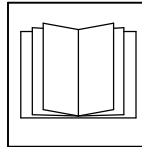

READ INSTRUCTIONS.

- Read and follow all labels and the Owner's Manual carefully before installing, operating, or servicing unit. Read the safety information at the beginning of the manual and in each section.
- Use only genuine replacement parts from the manufacturer.
- Perform maintenance and service according to the Owner's Manuals, industry standards, and national, state, and local codes.

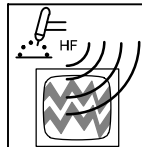

H.F. RADIATION can cause interference.

- High-frequency (H.F.) can interfere with radio navigation, safety services, computers, and communications equipment.
- Have only qualified persons familiar with electronic equipment perform this installation.
- The user is responsible for having a qualified electrician promptly correct any interference problem resulting from the installation.
- If notified by the FCC about interference, stop using the equipment at once.
- Have the installation regularly checked and maintained.
- Keep high-frequency source doors and panels tightly shut, keep spark gaps at correct setting, and use grounding and shielding to minimize the possibility of interference.

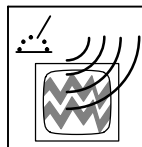

ARC WELDING can cause interference.

- Electromagnetic energy can interfere with sensitive electronic equipment such as computers and computer-driven equipment such as robots.
- Be sure all equipment in the welding area is electromagnetically compatible.
- To reduce possible interference, keep weld cables as short as possible, close together, and down low, such as on the floor.
- Locate welding operation 100 meters from any sensitive electronic equipment.
- Be sure this welding machine is installed and grounded according to this manual.
- If interference still occurs, the user must take extra measures such as moving the welding machine, using shielded cables, using line filters, or shielding the work area.

1-4. California Proposition 65 Warnings

 **Welding or cutting equipment produces fumes or gases which contain chemicals known to the State of California to cause birth defects and, in some cases, cancer. (California Health & Safety Code Section 25249.5 et seq.)**

 **This product contains chemicals, including lead, known to the state of California to cause cancer, birth defects, or other reproductive harm. Wash hands after use.**

1-5. Principal Safety Standards

Safety in Welding, Cutting, and Allied Processes, ANSI Standard Z49.1, is available as a free download from the American Welding Society at <http://www.aws.org> or purchased from Global Engineering Documents (phone: 1-877-413-5184, website: www.global.ihs.com).

Safe Practices for the Preparation of Containers and Piping for Welding and Cutting, American Welding Society Standard AWS F4.1, from Global Engineering Documents (phone: 1-877-413-5184, website: www.global.ihs.com).

Safe Practices for Welding and Cutting Containers that have Held Combustibles, American Welding Society Standard AWS A6.0, from Global Engineering Documents (phone: 1-877-413-5184, website: www.global.ihs.com).

National Electrical Code, NFPA Standard 70, from National Fire Protection Association, Quincy, MA 02269 (phone: 1-800-344-3555, website: www.nfpa.org and www.sparky.org).

Safe Handling of Compressed Gases in Cylinders, CGA Pamphlet P-1, from Compressed Gas Association, 14501 George Carter Way, Suite 103, Chantilly, VA 20151 (phone: 703-788-2700, website: www.cganet.com).

Safety in Welding, Cutting, and Allied Processes, CSA Standard W117.2, from Canadian Standards Association, Standards Sales, 5060

Spectrum Way, Suite 100, Ontario, Canada L4W 5NS (phone: 800-463-6727, website: www.csa-international.org).

Safe Practice For Occupational And Educational Eye And Face Protection, ANSI Standard Z87.1, from American National Standards Institute, 25 West 43rd Street, New York, NY 10036 (phone: 212-642-4900, website: www.ansi.org).

Standard for Fire Prevention During Welding, Cutting, and Other Hot Work, NFPA Standard 51B, from National Fire Protection Association, Quincy, MA 02269 (phone: 1-800-344-3555, website: www.nfpa.org).

OSHA, Occupational Safety and Health Standards for General Industry, Title 29, Code of Federal Regulations (CFR), Part 1910, Subpart Q, and Part 1926, Subpart J, from U.S. Government Printing Office, Superintendent of Documents, P.O. Box 371954, Pittsburgh, PA 15250-7954 (phone: 1-866-512-1800) (there are 10 OSHA Regional Offices—phone for Region 5, Chicago, is 312-353-2220, website: www.osha.gov).

Applications Manual for the Revised NIOSH Lifting Equation, The National Institute for Occupational Safety and Health (NIOSH), 1600 Clifton Rd, Atlanta, GA 30333 (phone: 1-800-232-4636, website: www.cdc.gov/NIOSH).

1-6. EMF Information

Electric current flowing through any conductor causes localized electric and magnetic fields (EMF). The current from arc welding (and allied processes including spot welding, gouging, plasma arc cutting, and induction heating operations) creates an EMF field around the welding circuit. EMF fields may interfere with some medical implants, e.g. pacemakers. Protective measures for persons wearing medical implants have to be taken. For example, restrict access for passers-by or conduct individual risk assessment for welders. All welders should use the following procedures in order to minimize exposure to EMF fields from the welding circuit:

1. Keep cables close together by twisting or taping them, or using a cable cover.
2. Do not place your body between welding cables. Arrange cables to one side and away from the operator.
3. Do not coil or drape cables around your body.







4. Keep head and trunk as far away from the equipment in the welding circuit as possible.
5. Connect work clamp to workpiece as close to the weld as possible.
6. Do not work next to, sit or lean on the welding power source.
7. Do not weld whilst carrying the welding power source or wire feeder.



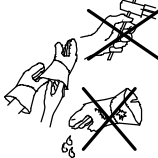
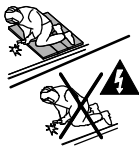
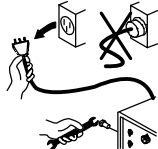

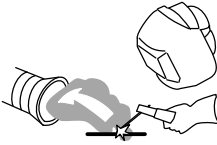
About Implanted Medical Devices:

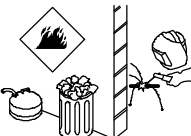
Implanted Medical Device wearers should consult their doctor and the device manufacturer before performing or going near arc welding, spot welding, gouging, plasma arc cutting, or induction heating operations. If cleared by your doctor, then following the above procedures is recommended.





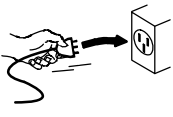
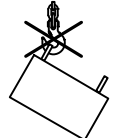

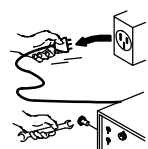
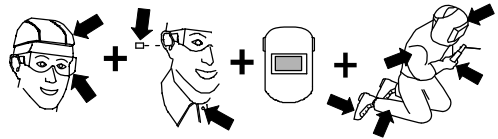
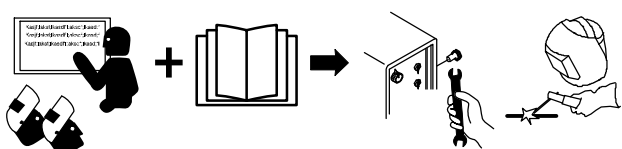
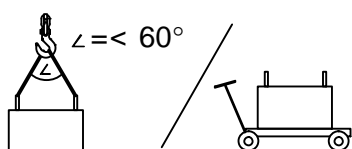
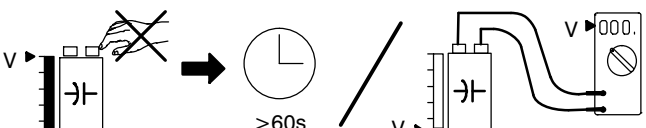

SECTION 2 – DEFINITIONS





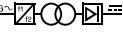

2-1. Additional Safety Symbols And Definitions



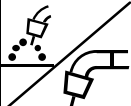



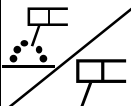

	<p>Warning! Watch Out! There are possible hazards as shown by the symbols.</p> <p style="text-align: right;">Safe1 2012-05</p>
	<p>Wear dry insulating gloves. Do not touch electrode with bare hand. Do not wear wet or damaged gloves.</p> <p style="text-align: right;">Safe2 2012-05</p>
	<p>Protect yourself from electric shock by insulating yourself from work and ground.</p> <p style="text-align: right;">Safe3 2012-05</p>
	<p>Disconnect input plug or power before working on machine.</p> <p style="text-align: right;">Safe5 2012-05</p>
	<p>Keep your head out of the fumes.</p> <p style="text-align: right;">Safe6 2012-05</p>
	<p>Use forced ventilation or local exhaust to remove the fumes.</p> <p style="text-align: right;">Safe8 2012-05</p>
	<p>Use ventilating fan to remove fumes.</p> <p style="text-align: right;">Safe10 2012-05</p>
	<p>Keep flammables away from welding. Do not weld near flammables.</p> <p style="text-align: right;">Safe12 2012-05</p>
	<p>Welding sparks can cause fires. Have a fire extinguisher nearby, and have a watchperson ready to use it.</p> <p style="text-align: right;">Safe14 2012-05</p>
	<p>Do not remove or paint over (cover) the label.</p> <p style="text-align: right;">Safe20 2012-05</p>

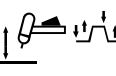
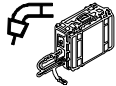
	<p>When power is applied failed parts can explode or cause other parts to explode.</p> <p style="text-align: right;">Safe26 2012-05</p>
	<p>Always wear long sleeves and button your collar when servicing unit.</p> <p style="text-align: right;">Safe28 2012-05</p>
	<p>After taking proper precautions as shown, connect power to unit.</p> <p style="text-align: right;">Safe29 2012-05</p>
	<p>Do not use one handle to lift or support unit.</p> <p style="text-align: right;">Safe31 2012-05</p>
	<p>Do not weld on drums or any closed containers.</p> <p style="text-align: right;">Safe16 2012-05</p>
	<p>Do not discard product (where applicable) with general waste. Reuse or recycle Waste Electrical and Electronic Equipment (WEEE) by disposing at a designated collection facility. Contact your local recycling office or your local distributor for further information.</p> <p style="text-align: right;">Safe37 2012-05</p>
	<p>Disconnect input plug or power before working on machine.</p> <p style="text-align: right;">Safe30 2012-05</p>
	<p>Wear hat and safety glasses. Use ear protection and button shirt collar. Use welding helmet with correct shade of filter. Wear complete body protection.</p> <p style="text-align: right;">Safe38 2012-05</p>
	<p>Become trained and read the instructions before working on the machine or welding.</p> <p style="text-align: right;">Safe40 2012-05</p>
	<p>Always lift and support unit using both handles. Keep angle of lifting device less than 60 degrees. Use a proper cart to move unit.</p> <p style="text-align: right;">Safe44 2012-05</p>
	<p>Hazardous voltage remains on input capacitors after power is turned off. Do not touch fully charged capacitors. Always wait 60 seconds after power is turned off before working on unit, OR check input capacitor voltage, and be sure it is near 0 before touching any parts.</p> <p style="text-align: right;">Safe42 2012-05</p>

2-2. Miscellaneous Symbols And Definitions

A	Amperage
	Alternating Current (AC)
V	Voltage
I	On
	Voltage Input
	Protective Earth (Ground)
	Line Connection
	Three Phase Static Frequency Converter-Transformer-Rectifier
X	Duty Cycle
%	Percent
3 	Three Phase
	Lift-Arc Operation (GTAW)
	Remote
-	Negative
	Inductance

	Foot Control
	Gas Metal Arc Welding (GMAW)
U₂	Conventional Load Voltage
I₂	Rated Welding Current
	Panel
1 	Single Phase
	Circuit Breaker
	Gas Tungsten Arc Welding
+	Positive
	Constant Voltage
	Shielded Metal Arc Welding (SMAW)
U₁	Primary Voltage
IP	Degree Of Protection

	Lift-Arc Trigger Hold Operation (GTAW)
I_{1eff}	Maximum Effective Supply Current
	Voltage Sensing Feeder
	Output
	Off
	Direct Current (DC)
	Constant Current
	Arc Force
U₀	Rated No Load Voltage (Average)
Hz	Hertz
	Pulsed
I_{1max}	Rated Maximum Supply Current
	Scratch Start TIG
	Increase

SECTION 3 – SPECIFICATIONS

3-1. Serial Number And Rating Label Location

The serial number and rating information for this product is located on the rear panel. Use rating label to determine input power requirements and/or rated output. For future reference, write serial number in space provided on back cover of this manual.

3-2. Unit Specifications

⚠ Do not use information in unit specifications table to determine electrical service requirements. See Sections 4-7 and 4-8 for information on connecting input power.

Input Power	Rated Output	Voltage Range in CV Mode	Amperage Range in CC Mode	Max. Open-Circuit Voltage	RMS Amps Input at Rated Load Output, 50/60 Hz 3-Phase at NEMA Load Voltages and Class I Rating				KVA	KW
					230 V	380 V	400 V	460 V		
3-Phase	350 A at 34 VDC, 60% Duty Cycle	10–38 V	5–425 A	75 VDC	36.1	22.3	20.6	17.8	14.2	13.6

*See Section 3-5 for Duty Cycle Rating.

3-3. Dimensions And Weight

Hole Layout Dimensions	
A	(298 mm) 11-3/4 in.
B	(42 mm) 1-11/16 in.
C	(400 mm) 15-3/4 in.
D	(485 mm) 19-3/32 in.
E	(221 mm) 8-11/16 in.
F	(39 mm) 1-17/32 in.
G	1/4-20 UNC -2B thread
Weight	
94.8 lb (43 kg)	

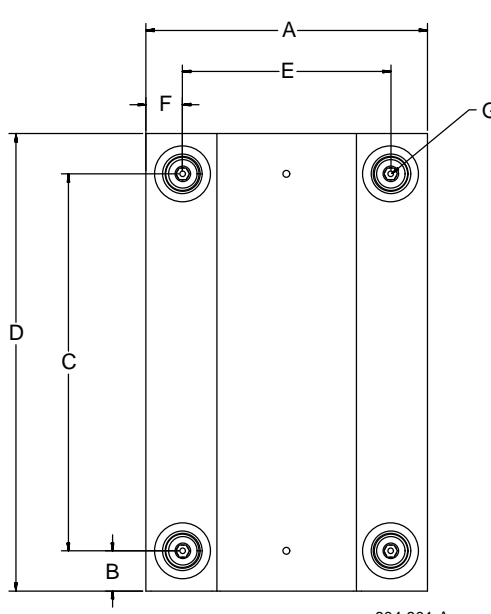
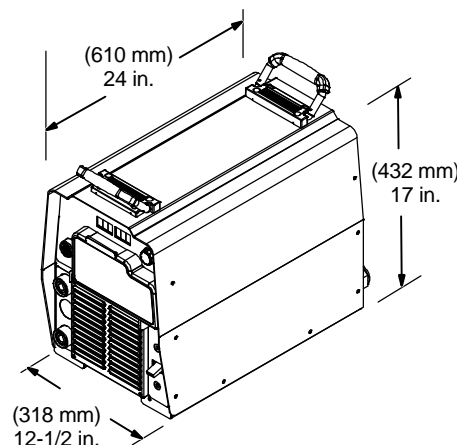
804 801-A

3-4. Environmental Specifications

A. IP Rating

IP Rating
IP23
This equipment is designed for outdoor use. It may be stored, but is not intended to be used for welding outside during precipitation unless sheltered.
IP23 2014-06

4-2. Selecting Cable Sizes*

NOTICE – The Total Cable Length in Weld Circuit (see table below) is the combined length of both weld cables. For example, if the power source is 30 m (100 ft) from the workpiece, the total cable length in the weld circuit is 60 m (2 cables x 30 m). Use the 60 m (200 ft) column to determine cable size.

Welding Amperes	Weld Cable Size** and Total Cable (Copper) Length in Weld Circuit Not Exceeding***							
	30 m (100 ft) or Less		45 m (150 ft)	60 m (200 ft)	70 m (250 ft)	90 m (300 ft)	105 m (350 ft)	120 m (400 ft)
	10 – 60% Duty Cycle mm ² (AWG)	60 – 100% Duty Cycle mm ² (AWG)	10 – 100% Duty Cycle mm ² (AWG)					
100	20 (4)	20 (4)	20 (4)	30 (3)	35 (2)	50 (1)	60 (1/0)	60 (1/0)
150	30 (3)	30 (3)	35 (2)	50 (1)	60 (1/0)	70 (2/0)	95 (3/0)	95 (3/0)
200	30 (3)	35 (2)	50 (1)	60 (1/0)	70 (2/0)	95 (3/0)	120 (4/0)	120 (4/0)
250	35 (2)	50 (1)	60 (1/0)	70 (2/0)	95 (3/0)	120 (4/0)	2x70 (2x2/0)	2x70 (2x2/0)
300	50 (1)	60 (1/0)	70 (2/0)	95 (3/0)	120 (4/0)	2x70 (2x2/0)	2x95 (2x3/0)	2x95 (2x3/0)
350	60 (1/0)	70 (2/0)	95 (3/0)	120 (4/0)	2x70 (2x2/0)	2x95 (2x3/0)	2x95 (2x3/0)	2x120 (2x4/0)
400	60 (1/0)	70 (2/0)	95 (3/0)	120 (4/0)	2x70 (2x2/0)	2x95 (2x3/0)	2x120 (2x4/0)	2x120 (2x4/0)
500	70 (2/0)	95 (3/0)	120 (4/0)	2x70 (2x2/0)	2x95 (2x3/0)	2x120 (2x4/0)	3x95 (3x3/0)	3x95 (3x3/0)
600	95 (3/0)	120 (4/0)	2x70 (2x2/0)	2x95 (2x3/0)	2x120 (2x4/0)	3x95 (3x3/0)	3x120 (3x4/0)	3x120 (3x4/0)

* This chart is a general guideline and may not suit all applications. If cable overheats, use next size larger cable.

**Weld cable size is based on either a 4 volts or less drop or a current density of at least 300 circular mils per ampere.

***For distances longer than those shown in this guide, call a factory applications representative.

Milan Ref. S-0007-L 2015-02

4-3. Weld Output Terminals

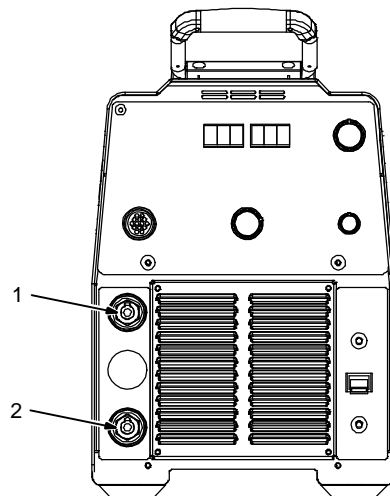



⚠ Turn off power before connecting to weld output terminals.

⚠ Do not use worn, damaged, undersized, or repaired cables.

- 1 Positive (+) Weld Output Terminal
- 2 Negative (-) Weld Output Terminal

Ref. 803 692-B / output term1 2015-02

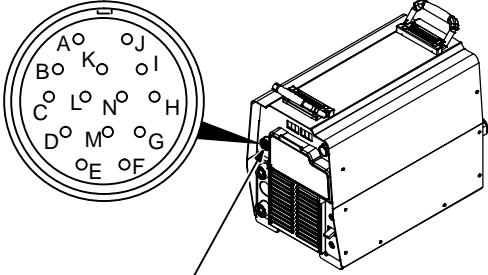
4-4. Remote 14 Receptacle Information

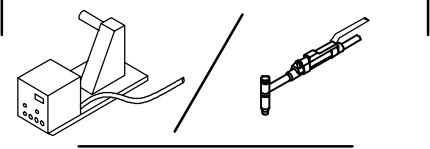
	 REMOTE 14	Socket*	Socket Information
24 VOLTS AC  OUTPUT (CONTACTOR)		A	24 volts AC. Protected by supplementary protector or CB2.
		B	Contact closure to A completes 24 volts AC contactor control circuit.
REMOTE OUTPUT CONTROL		C	Output to remote control; 0 to +10 volts DC, +10 volts DC in MIG mode.
		D	Remote control circuit common.
		E	0 to +10 volts DC input command signal from remote control.
A/V AMPERAGE VOLTAGE		F	Current feedback; +1 volt DC per 100 weld amperes.
		H	Voltage feedback; +1 volt DC per 10 weld volts.
GND		G	Circuit common for 24 and 115 volts AC circuits.
		K	Chassis common.

*The remaining sockets are not used.

4-5. 115 Volts AC Duplex Receptacle And Supplementary Protectors

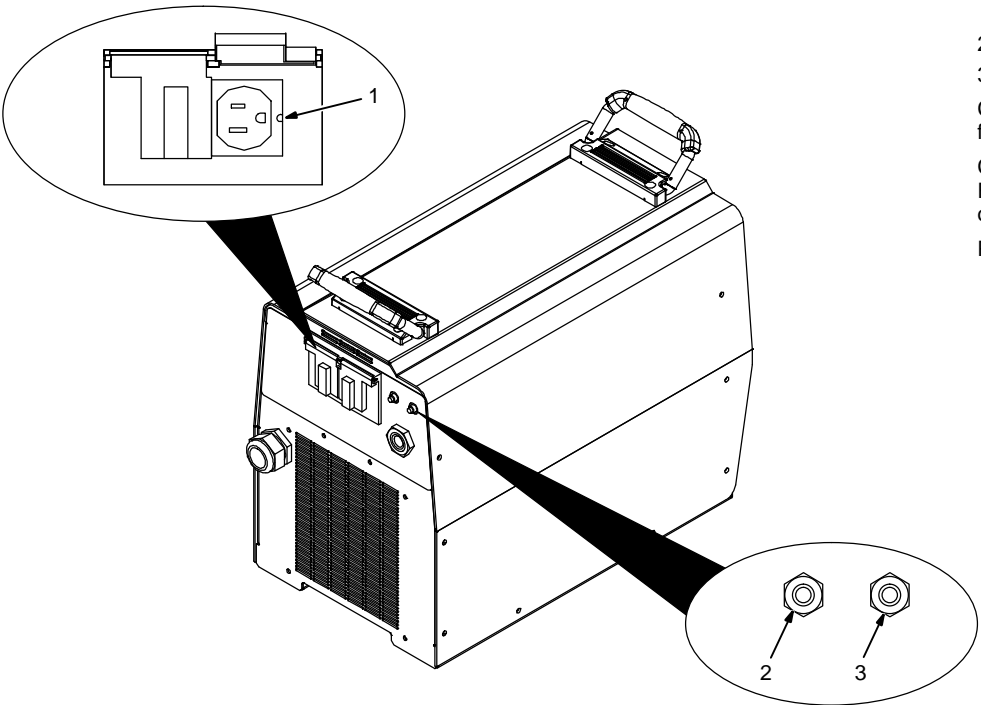

- 1 115 V 10 Amp. AC Receptacle
- 2 Supplementary Protector CB1
- 3 Supplementary Protector CB2

CB1 protects the duplex receptacle from overload.

CB2 protects 24 volts AC portion of Remote 14 receptacle from overload.

Press button to reset protector.

Ref. 803 879-B

4-6. Optional Gas Valve Operation And Shielding Gas Connection

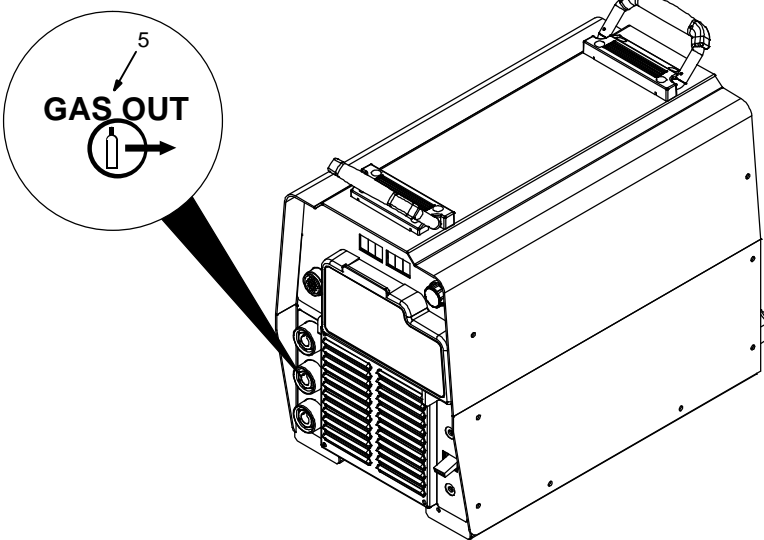
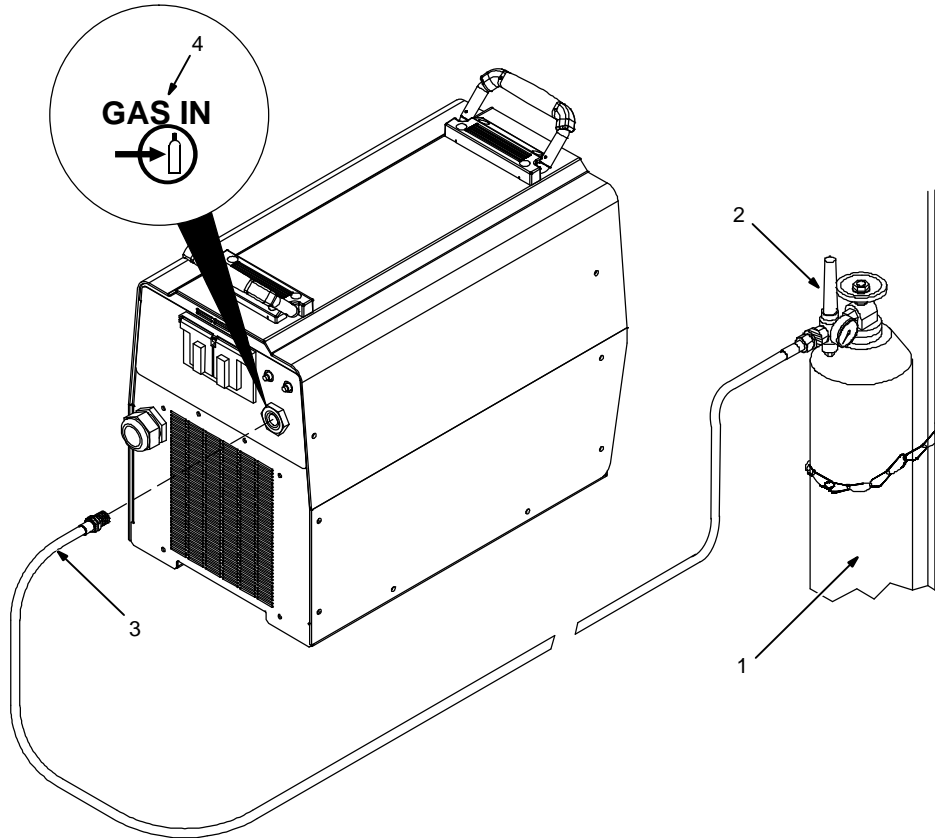

Obtain gas cylinder and chain to running gear, wall, or other stationary support so cylinder cannot fall and break off valve.

- 1 Cylinder
- 2 Regulator/Flowmeter
- 3 Gas Hose Connection

Install so face is vertical.

Fitting has 5/8-18 right-hand threads. Obtain and install gas hose.

- 4 Gas In Fitting
- 5 Gas Out Fitting

The Gas In and Gas Out fittings have 5/8-18 right-hand threads. Obtain proper size, type, and length hose and make connections as follows:

Connect hose from shielding gas supply regulator/flowmeter to Gas In fitting.

Connect hose coupler to torch. Connect one end of gas hose to hose coupler. Connect remaining end of gas hose to Gas Out fitting.

Operation

The gas solenoid controls gas flow during the TIG process as follows:

Remote TIG

Gas flow starts with remote contactor on.

Gas flow stops at end of post-flow if current was detected, or with remote contactor off if no current was detected.

Lift-Arc Trigger Hold TIG

Gas flow starts when output switch is depressed.

Gas flow stops at end of post-flow.

Scratch Start TIG

Gas flow starts when current is detected.

Gas flow stops at end of post-flow.

Post-flow time is factory set to 5 seconds per 100 amps of weld current. The minimum post-flow time is 5 seconds. The maximum post-flow is 20 seconds (post flow settings are not adjustable by the end user).

Ref. 803 705-B / Ref. 803 879-B

4-8. Connecting 3-Phase Input Power

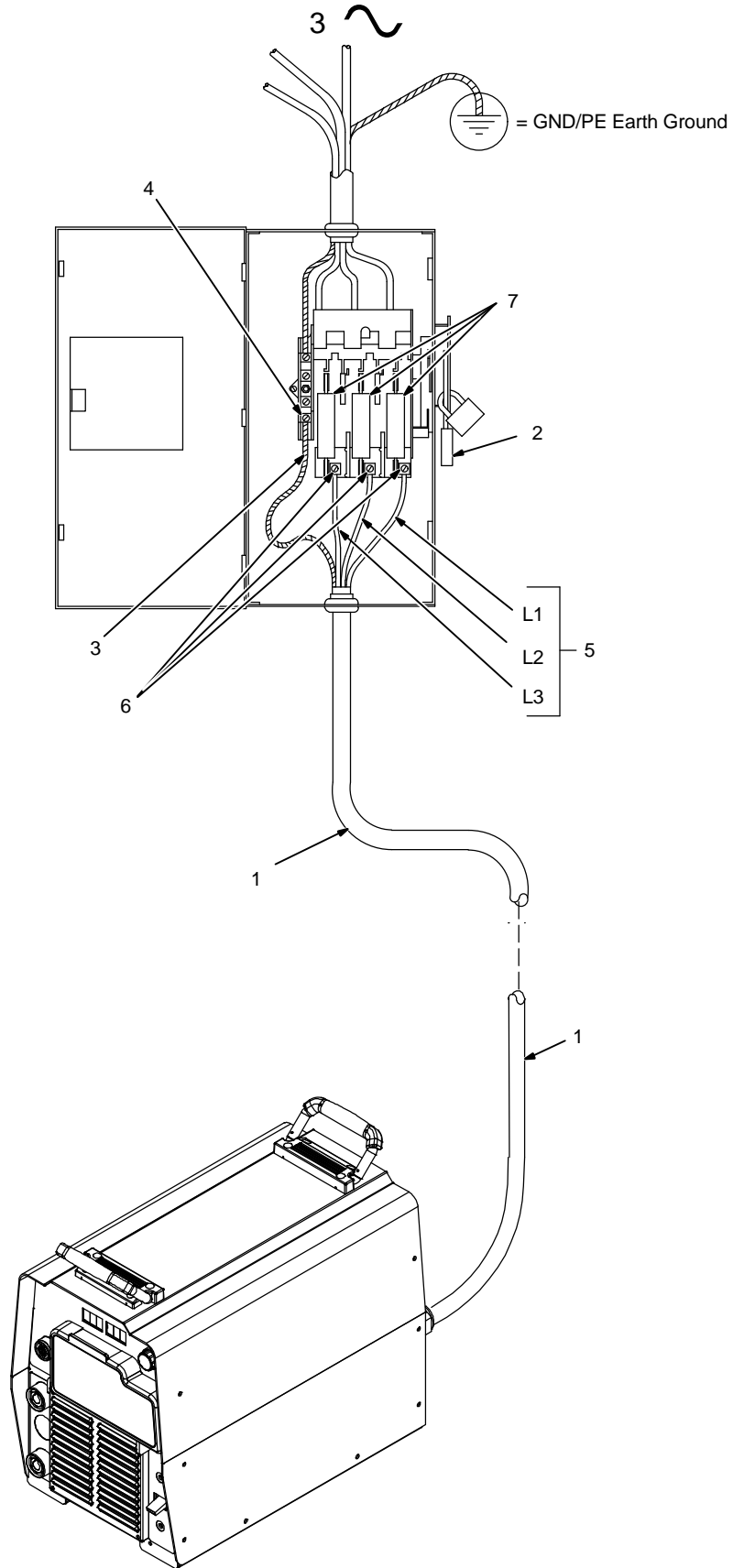

Tools Needed:



Input2 2012-05 – Ref. 803 766-C / Ref. 802 136-A / Ref. 803 879-B

SECTION 5 – OPERATION

5-1. Front Panel Controls

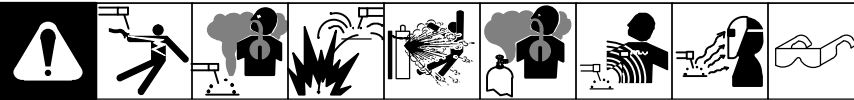

1 Power Switch

The fan motor is thermostatically controlled and only runs when cooling is needed.

2 Voltmeter

3 Ammeter

4 V/A (Voltage/Amperage) Adjustment Control

5 Mode Switch

The Mode switch setting determines both the process and output On/Off control (see Section 5-3).

For Air Carbon Arc (CAC-A) cutting and gouging, place switch in Stick position. For best results, place Arc Control in the maximum position.

6 Remote 14 Receptacle

For remote control, make connections to Remote 14 receptacle. In TIG modes and the REMOTE STICK mode, remote control is a percent of V/A Adjust control setting (value selected on V/A Adjust). In ELECTRODE HOT STICK mode the remote control is not used. In the MIG mode, remote control provides full range of unit output regardless of V/A Adjust control setting.

7 Arc Control

Control adjusts Dig when Stick or CC mode is selected on mode switch. When set towards minimum, short-circuit amperage at low arc

voltage is the same as normal welding amperage.

When set towards maximum, short-circuit amperage is increased at low arc voltage to assist with arc starts as well as reduce sticking while welding.

Select setting best suited for application.

Control adjusts inductance when MIG or V-Sense Feeder position is selected on the mode switch. Inductance determines the "wetness" of the weld puddle. When set towards maximum, "wetness" (puddle fluidity) increases.

When Pulsed MIG or one of the TIG modes is selected, this control is not functional.

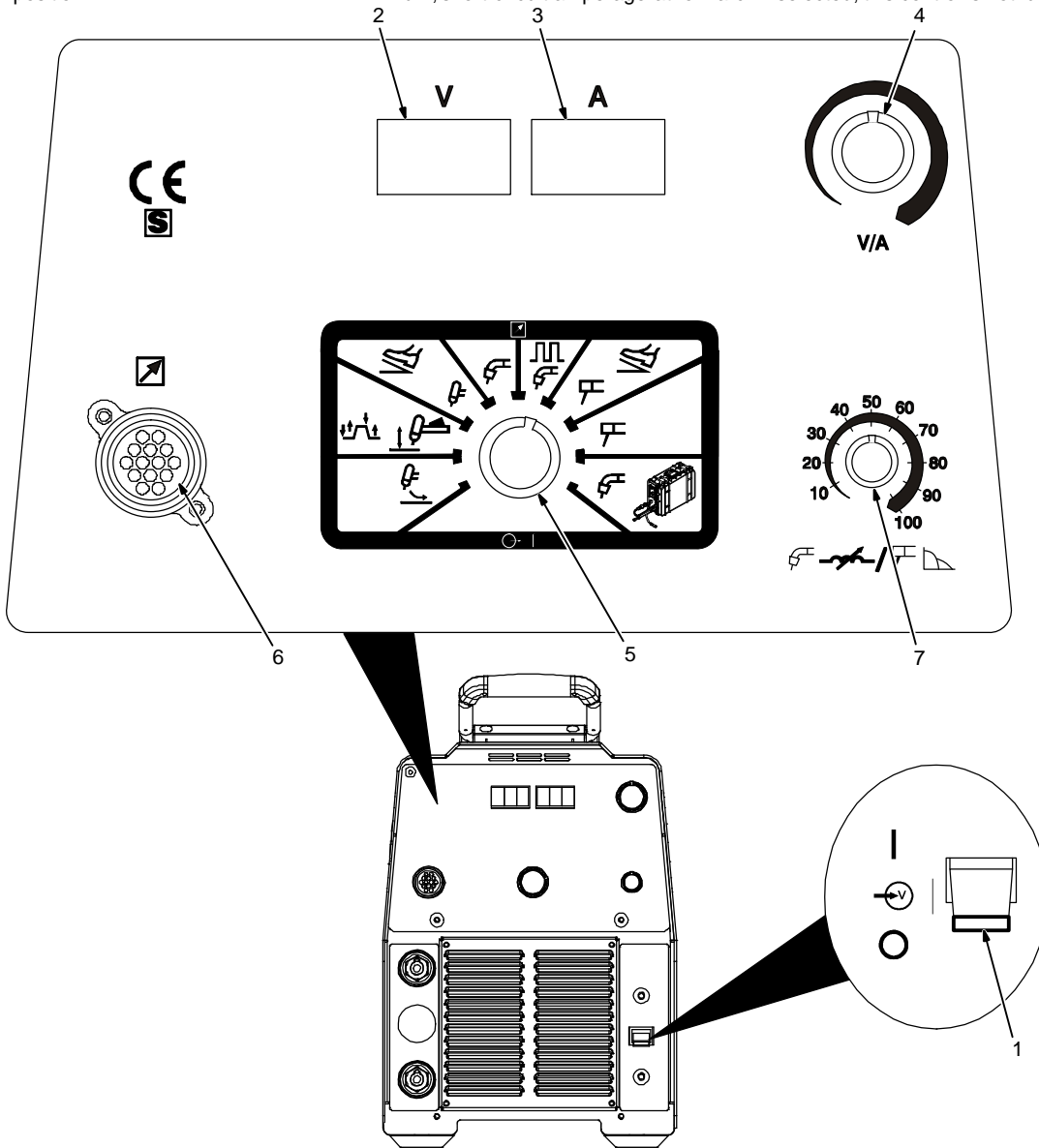

Ref. 803 692-B / Ref. 219 341-A

5-2. Meter Functions

 The meters display the actual weld output values for approximately three seconds after the arc is broken.

Mode	Meter Reading At Idle		Meter Reading While Welding	
Scratch Start TIG	V 71.7 Actual Volts (OCV)	A 85 Preset Amps	V 10.3 Actual Volts	A 85 Actual Amps
Lift-Arc Trigger Hold TIG	V Blank	A 85 Preset Amps	V 10.3 Actual Volts	A 85 Actual Amps
TIG	V Blank	A 85 Preset Amps	V 10.3 Actual Volts	A 85 Actual Amps
MIG	V 24.5 Preset Volts	A Blank	V 24.5 Actual Volts	A 250 Actual Amps
Pulsed MIG	V PPP Pulse Display	A PPP Pulse Display	V 24.5 Actual Volts	A 250 Actual Amps
CC	V Blank	A 85 Preset Amps	V 24.5 Actual Volts	A 85 Actual Amps
Stick	V 71.7 Actual Volts (OCV)	A 85 Preset Amps	V 24.5 Actual Volts	A 85 Actual Amps
V-Sense Feeder	V 71.7 Flashes OCV And Preset	A Blank	V 24.5 Actual Volts	A 250 Actual Amps

5-3. Mode Switch Settings

 The Stick and CC modes provide the Adaptive Hot Start™ feature, which automatically increases the output amperage at the start of a weld should the start require it. This eliminates electrode sticking at arc start.

Mode Switch Setting	Process	Output On/Off Control
Scratch Start TIG	GTAW	Electrode Hot
Lift-Arc Trigger Hold TIG	GTAW – See Section 5-4	At Remote 14
TIG	GTAW With HF Unit, Pulsing Device, Or Remote Control	At Remote 14
MIG	GMAW	At Remote 14
Pulsed MIG	GMAW-P (Requires an external pulsing device.)	At Remote 14
CC	Stick (SMAW) With Remote On/Off	At Remote 14
Stick	SMAW	Electrode Hot
V-Sense Feeder	MIG (GMAW) With Voltage Sensing Wire Feeder	Electrode Hot

5-4. Lift-Arc Trigger Hold TIG

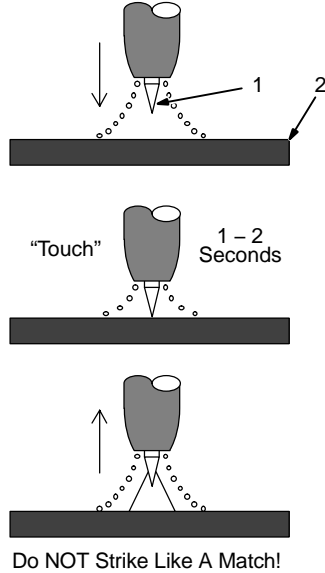
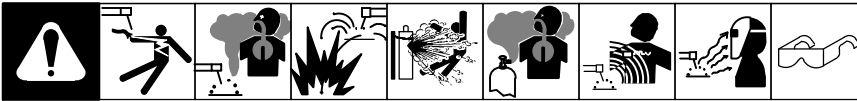

- 1 TIG Electrode
- 2 Workpiece

 Procedure requires:

  control

Start sequence:

- Touch tungsten electrode to workpiece at weld start point.
- Momentarily depress output switch.
- Slowly lift electrode. An arc will form when electrode is lifted.
- To stop welding, momentarily depress output switch and output will shut off.

Note: If output switch is momentarily depressed and tungsten is not touching workpiece:

Do not touch tungsten to work.

Output will shut off in 3 seconds.

Start sequence over.

Ref. S-156 279

5-5. Stick Start Procedure

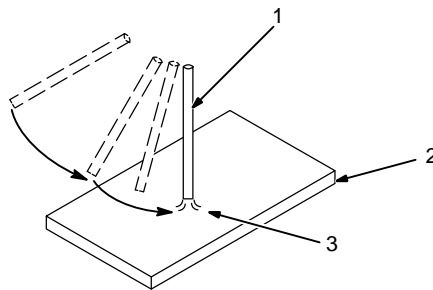
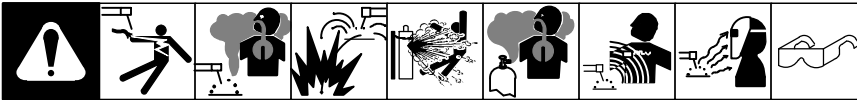

With Stick selected, start arc as follows:

- 1 Electrode
- 2 Workpiece
- 3 Arc

Drag electrode across workpiece like striking a match; lift electrode slightly after touching work. If arc goes out electrode was lifted too high. If electrode sticks to workpiece, use a quick twist to free it.

Low OCV Stick

The unit can be optionally configured for low open circuit voltage (OCV) operation. When the unit is configured for low OCV operation only a low sensing voltage (approximately 15 VDC) is present between the electrode and the workpiece prior to the electrode touching the workpiece. Consult a Factory Authorized Service Agent for information regarding how to configure the unit for low OCV stick welding operation.

SECTION 6 – MAINTENANCE & TROUBLESHOOTING

6-1. Routine Maintenance

		Disconnect power before maintaining.		<i>Maintain more often during severe conditions.</i>
3 Months				
		Replace Damaged Or Unreadable Labels		Repair Or Replace Cracked Cables
				Replace Cracked Torch Body
				Repair Or Replace Cracked Cables And Cords
				Clean And Tighten Weld Connections
6 Months				
				Blow Out Inside

6-2. Blowing Out Inside Of Unit

			Do not remove case when blowing out inside of unit.
To blow out unit, direct airflow through front and back louvers as shown.			
Ref. 803 879-B			

6-3. Voltmeter/Ammeter Help Displays

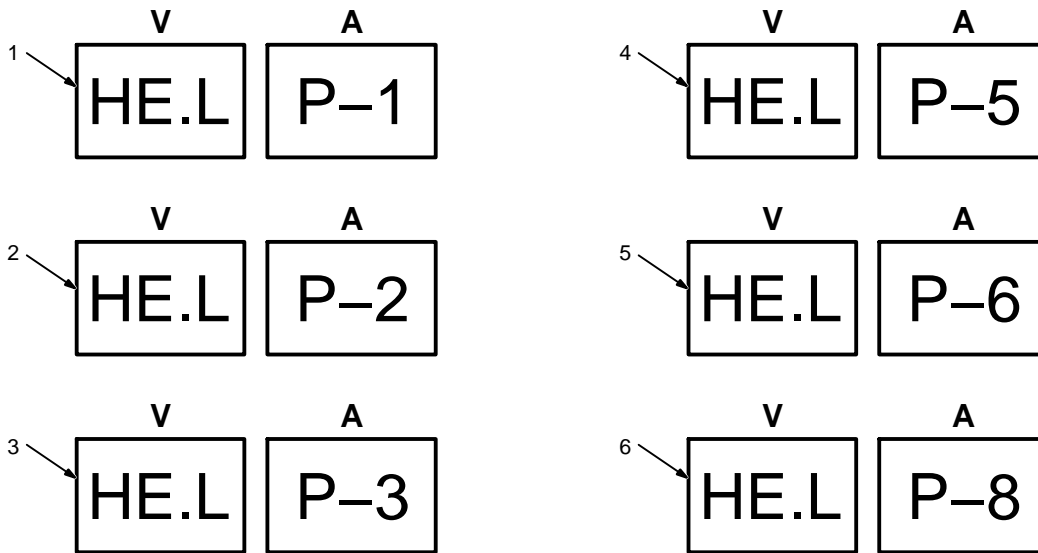

 All directions are in reference to the front of the unit. All circuitry referred to is located inside the unit.

1 Help 1 Display

Indicates a malfunction in the primary power circuit. If this display is shown, contact a Factory Authorized Service Agent.

2 Help 2 Display

Indicates a malfunction in the thermal protection circuitry. If this display is shown, contact a Factory Authorized Service Agent.

3 Help 3 Display

Indicates the left side of the unit has overheated. The unit has shut down to allow the fan to cool it (see Section 3-5). Operation will continue when the unit has cooled.

4 Help 5 Display

Indicates the right side of the unit has overheated. The unit has shut down to allow the fan to cool it (see Section 3-5). Operation will continue when the unit has cooled.

5 Help 6 Display

Indicates operation at maximum input current. The unit has a maximum allowable input

current limit. As the line voltage decreases, the required input current increases. If the line voltage is too low, the output power is limited by the input current. When this limit is reached, the unit automatically reduces output power to continue operation. If this display is shown, have a qualified electrician check the input voltage.

6 Help 8 Display

Indicates a malfunction in the secondary power circuit of the unit. If this display is shown, contact a Factory Authorized Service Agent.

6-4. Troubleshooting

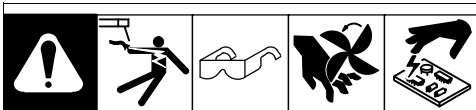

Trouble	Remedy
No weld output; unit completely inoperative.	Place line disconnect switch in On position (see Section 4-8).
	Check and replace line fuse(s), if necessary, or reset circuit breaker (see Section 4-8).
	Check for proper input power connections (see Section 4-8).
No weld output; meter display On.	Input voltage outside acceptable range of variation (see Sections 4-8, 4-7).
	Check, repair, or replace remote control.
	Unit overheated. Allow unit to cool with fan On (see Section 3-5).
Erratic or improper weld output.	Use proper size and type of weld cable (see Section 4-2).
	Clean and tighten all weld connections.
	Check for correct polarity.
No 115 volts AC output at duplex receptacle or Remote 14 receptacle.	Reset supplementary protector CB1 (see Section 4-5).
No 24 volts AC output at Remote 14 receptacle.	Reset supplementary protector CB2 (see Section 4-5).

SECTION 7 – ELECTRICAL DIAGRAM

	WARNING
	<ul style="list-style-type: none"> • Do not touch live electrical parts. • Disconnect input power or stop engine before servicing. • Do not operate with covers removed. • Have only qualified persons install, use, or service this unit.
ELECTRIC SHOCK HAZARD	

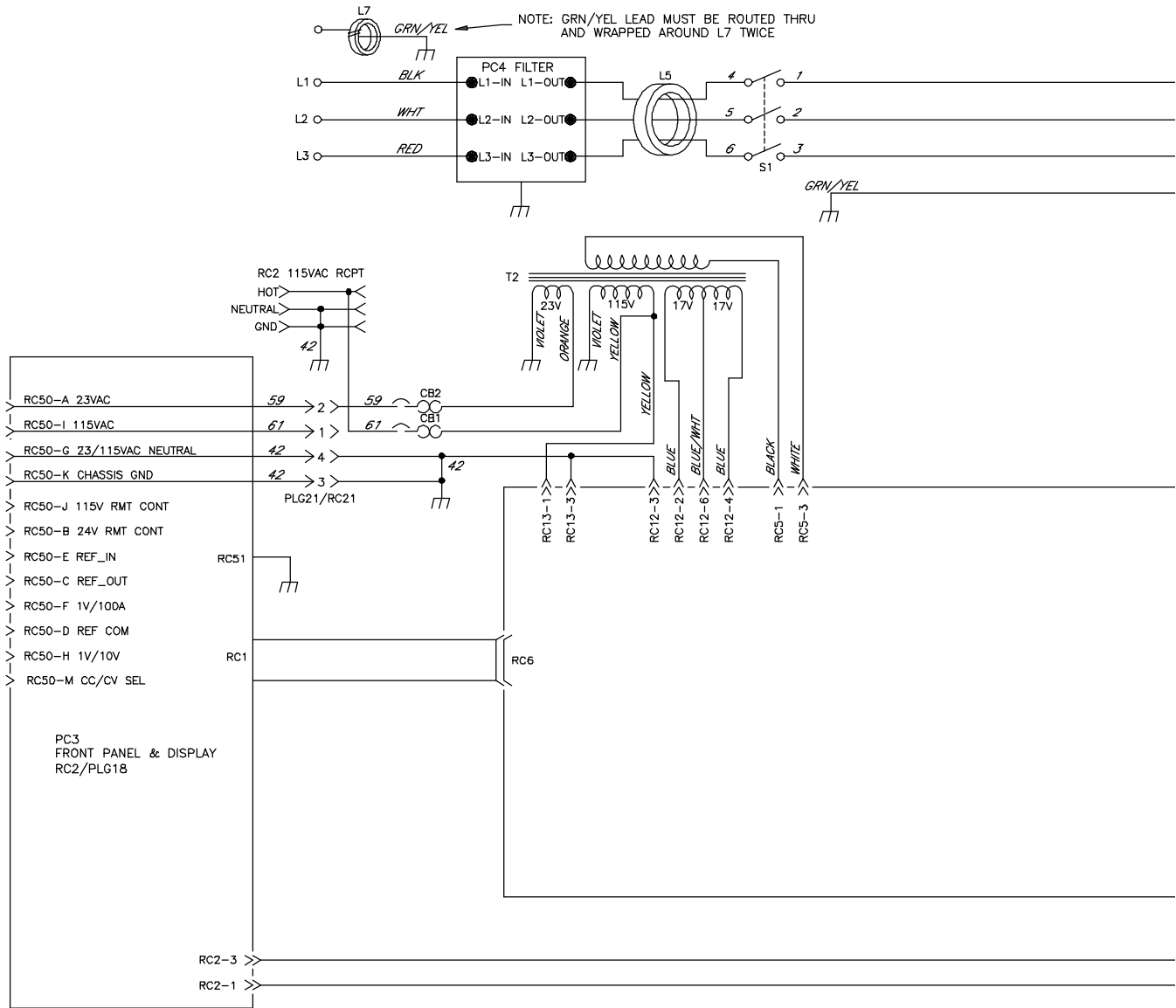
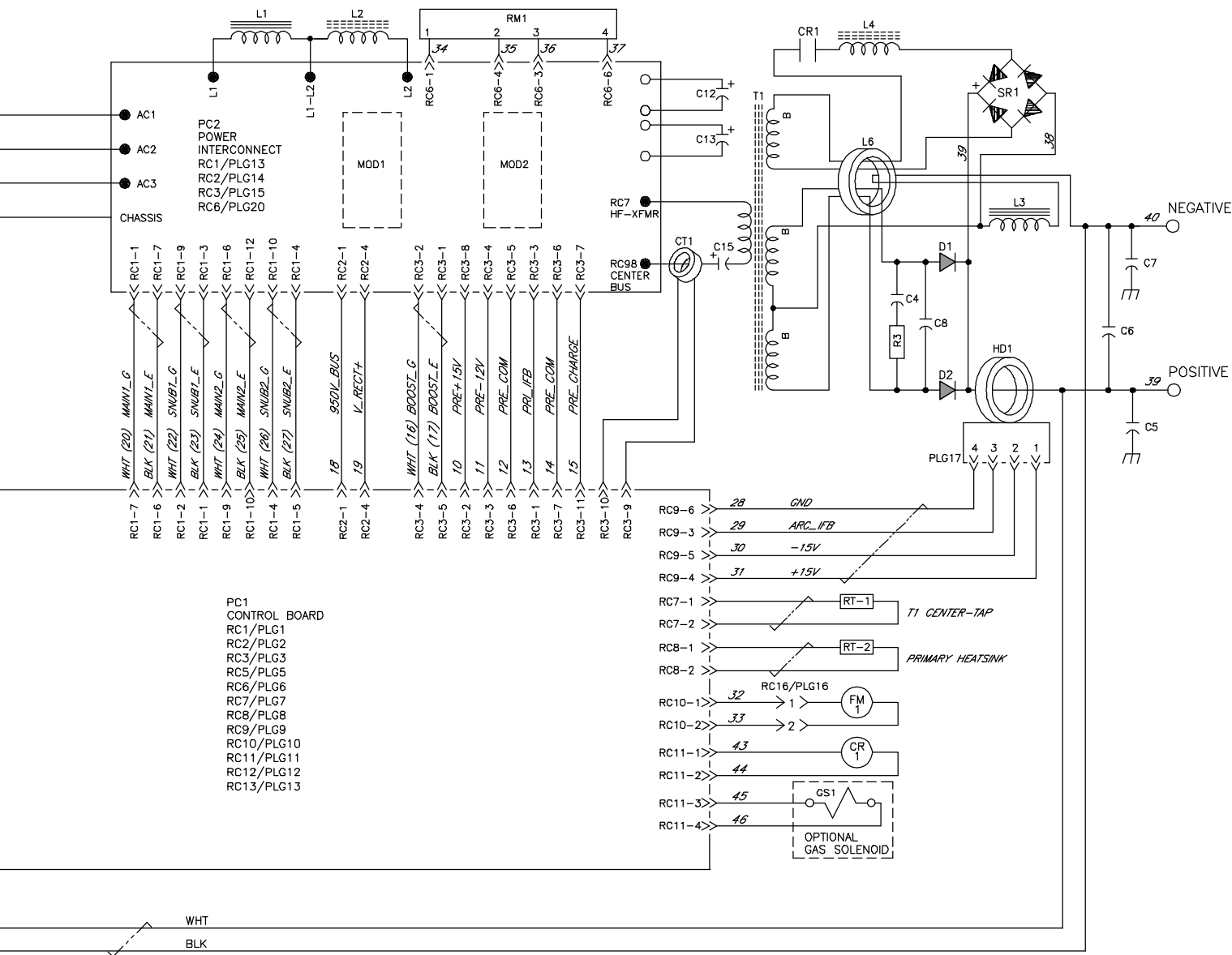
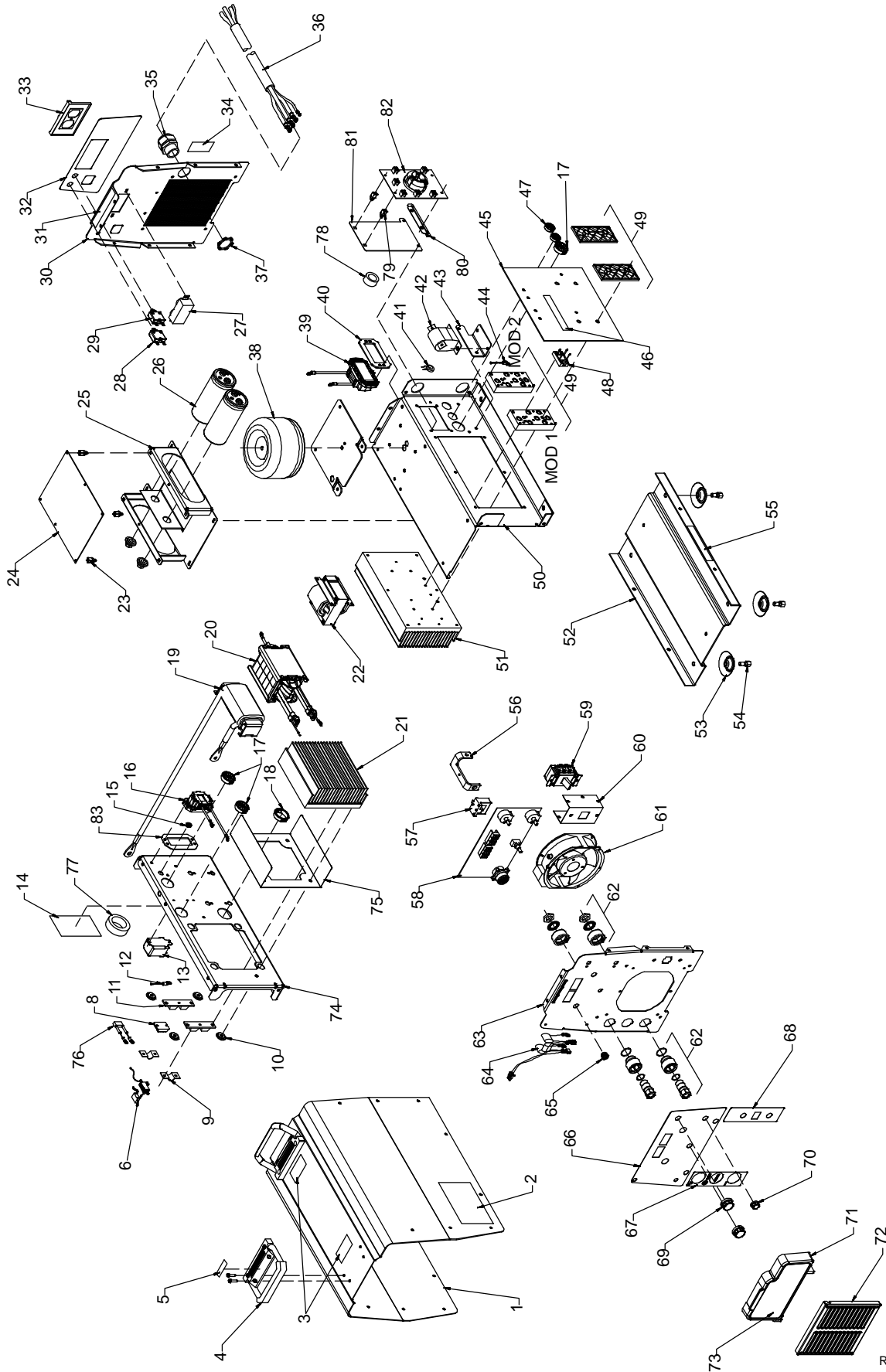

Figure 7-1. Circuit Diagram



SECTION 8 – PARTS LIST



Ref. 803 850-F

Figure 8.1. Parts Assembly

Item No.	Dia. Mkgs.	Part No.	Description	Quantity
Figure 8.1. Parts Assembly				
1		216034	Wrapper (Includes Insulators and Safety Labels)	1
		175256	Insulator, Side Rh (Not Shown)	1
		178551	Insulator, Side (Not Shown)	1
2		179310	Label, General Precautionary Wordless, Intl, Small	2
3		179309	Label, Caution Falling Equipment Can Injure—wordles	2
4		208015	Handle, Rubberized Carrying	2
5		135483	Label, Important Remove These Two Handle Screws	2
6	R3/C4	233052	Resistor/Capacitor	1
7		Deleted		
8	SR1	201530	Kit, Diode Fast Recovery Bridge	1
9		199840	Bus Bar, Diode	2
10		196355	Insulator, Screw	4
11	D1,D2	201531	Kit, Diode Power Module	2
12	RT1	219343	Thermistor, NTC 30K Ohm @ 25 Deg C 18in Lead	1
13	CR1	198549	Relay, Encl 24VDC Spst 35A/300VAC 4Pin Flange Mtg	1
14		227927	Label, Warning Electric Shock/Exploding Parts—wdles	1
15		010546	Bushing, Snap-In Nyl .375 Id X .500 Mtg Hole	1
16	L4	218020	Inductor, Boost	1
17		179276	Bushing, Snap-In Nyl 1.000 Id X 1.375 Mtg Hole Cent	3
18		170647	Bushing, Snap-In Nyl 1.312 Id X 1.500 Mtg Hole	1
19	L3	212150	Inductor, Output	1
20	T1	212132	XFMR, HF Litz/Litz W/Boost	1
21		225097	Heat Sink, Lh Rect	1
22	L1	212091	Inductor, Input	1
23		083147	Grommet, Scr No 8/10 Panel Hole .312 Sq .500 High	4
24	PC1	265280	Circuit Card Assy, Control W/Program	1
		216113	Stand-Off Support, PC Card .187 Dia W/P&I .375	2
	PLG1	115091	Housing Plug+Pins (Service Kit) RC1	1
	PLG2	201665	Housing Plug+Pins (Service Kit) RC2	1
	PLG3	131056	Housing Plug+Pins (Service Kit) RC3	1
	PLG5	131204	Housing Plug+Pins (Service Kit) RC5	1
	PLG7	131054	Housing Plug+Pins (Service Kit) RC7	1
	PLG8	131054	Housing Plug+Pins (Service Kit) RC8	1
	PLG9	115093	Housing Plug+Pins (Service Kit) RC9	1
	PLG10	115094	Housing Plug+Pins (Service Kit) RC10	1
	PLG11	115094	Housing Plug+Pins (Service Kit) RC11	1
	PLG12	115092	Housing Plug+Pins (Service Kit) RC12	1
25		212072	Bracket, Mtg Capacitor/Pc Board	1
26	C12, 13	245614	Capacitor, Elctlt 1800 Uf 500 VDC Can 2.52 Dia	2
27	RC2	604176	Rcpt, Str Dx Grd 2P3W 15A 125V *5-15R	1
28	CB2	083432	Circuit Breaker, Man Reset 1P 10A 250VAC Frict	1
29	CB1	083432	Circuit Breaker, Man Reset 1P 10A 250VAC Frict	1
30		+219470	Panel, Rear CE W/Aux	1
31		219335	Label, Warning Electric Shock Can Kill CE Wordless	1
32			Nameplate, Rear Aux/Gas/CE (Order by Model and Serial Number)	1
33		217297	Cover, Receptacle Weatherproof Duplex Rcpt	1
34		212945	Label, Warning Incorrect Connections CE Wordless	1
35		215980	Bushing, Strain Relief .709/.984 Id X1.375 Mtg Hole	1
36		244628	Cable, Power 12Ft 8Ga 4C (Non-Stripped End)	1

+When ordering a component originally displaying a precautionary label, the label should also be ordered.
BE SURE TO PROVIDE MODEL AND SERIAL NUMBER WHEN ORDERING REPLACEMENT PARTS.

Item No.	Dia. Mkgs.	Part No.	Description	Quantity
Figure 8.1. Parts Assembly (Continued)				
37		234126	Nut, Conduit 1.000 Npt Knurled	1
38	T2	270095	XFMR, Control Toroidal 665 VAC Pri 1536 Va 60 Hz	1
		212947	Plate, Mtg Toroid XFMR	1
39	L2	218018	Inductor, Pre-Regulator	1
40		218566	Gasket, Inductor Mounting	1
41	CT1	196231	XMFR, Current Sensing 200/1	1
42	C15	196143	Capacitor, Polyp Met Film 16. Uf 400 VAC 10%	1
43		219472	Bracket, Mtg Capacitor Series	1
44	RT2	199798	Thermistor, NTC 30K Ohm @ 25 Deg C 18in Lead	1
45	PC2	224661	Circuit Card Assy, Power Interconnect (Includes)	1
46		219335	Label, Warning Electric Shock Can Kill Ce Wordless	1
		223343	Clip, Wire Stdf .40-.50 Bndl .156Hole .031-.078Thk	2
	PLG13	130203	Housing Plug+Pins (Service Kit) RC1	1
	PLG14	201665	Housing Plug+Pins (Service Kit) RC2	1
	PLG15	115092	Housing Plug+Pins (Service Kit) RC3	1
	PLG20	115093	Housing Plug+Pins (Service Kit) RC6	1
47		153403	Bushing, Snap-In Nyl .750 Id X 1.000 Mtg Hole Cent	3
48	RM1	205751	Module, Power Resistor W/Plug	1
49		261556	Kit, Input/Pre-Regulator And Inverter Module (Includes)	1
			MOD 1, SKiip 83 HEC	1
			MOD 2, SKiip 83 EC	1
50		212206	Windtunnel, Rh	1
51		196330	Heat Sink, Power Module	1
52		+175132	Base	1
53		229325	Foot, Mtg Unit	4
54		176736	Screw, Mtg Foot	4
55		212073	Label, Warning Exploding Parts Can CE Wordless	1
56		212074	Bus Bar, Output	1
57	HD1	182918	Transducer, Current 400A Module Supply V +/- 15V	1
58	PC3	243654	Circuit Card Assy, Front Panel & Display W/Program	1
	PLG18	131204	Housing Plug+Pins (Service Kit) RC2	1
	RC50	210233	Rcpt, W/Pins (Service Kit)	1
	PLG21	212088	Plug, W/Leads	1
	RC21	167640	Housing Plug+Pins (Service Kit)	1
59	S1	244920	Switch, Tgl 3pst 40A 600VAC SCR Term Wide Tgl	1
60		176226	Insulator, Switch Power	1
61	FM1	196313	Fan, Muffin 115V 50/60Hz 3000 RPM 6.378 Mtg Holes	1
	PLG16	131054	Housing Plug+Pins (Service Kit)	1
	RC16	135635	Housing Plug+Pins (Service Kit)	1
62		208967	Rcpt Assy, Tw Lk Insul Fem (Dinse Type) 50/70 Series (Includes)	2
		208968	Rcpt, Tw Lk Insul W/O-Ring	1
		185712	Insulator, Bulkhead Front	1
		185713	Insulator, Bulkhead Rear	1
		185714	Washer, Tooth 22mmid X 31.5mmod 1.310-1mmt Intern	1
		185717	Nut, M20-1.5 1.00Hex .19H Brs Locking	1
		185718	O-Ring, 0.989 Id X 0.070 H	1
		186228	O-Ring, 0.739 Id X 0.070 H	1
63		212070	Panel, Front Standard	1
64	C5,6,7	233668	Capacitor Assy, W/Plug & Leads (Voltage Feedback)	1
65		216112	Fastener, Panel Receptacle Quick Access	2
66			Nameplate (Order by Model and Serial Number)	1
67			Nameplate, Connection (Order by Model and Serial Number)	1
68			Nameplate, Power (Order by Model and Serial Number)	1
69		174991	Knob, Pointer 1.250 Dia X .250 Id W/Spring Clip-.21	2

+When ordering a component originally displaying a precautionary label, the label should also be ordered.
BE SURE TO PROVIDE MODEL AND SERIAL NUMBER WHEN ORDERING REPLACEMENT PARTS.

Item No.	Dia. Mkgs.	Part No.	Description	Quantity
Figure 8.1. Parts Assembly (Continued)				
... 70		174992	.. Knob, Pointer .840 Dia X .250 Id W/Spring Clip-.21	1
... 71		218041	.. Door, W/Quick Access Ball Fasteners	1
... 72		175138	.. Box, Louver	1
... 73			Label (Order by Model and Serial Number)	1
... 74		+212207	.. Windtunnel, Lh	1
... 75		211503	.. Insulator, Heat Sink	1
... 76	C8	219191	.. Capacitor, Polyp Film .001 Uf 2000V W/Terms	1
... 77	L6	131447	.. Core, Toroidal 1.332 Id X 1.932 Od X .625 Thk	1
... 78	L5,L7	199122	.. Core, Toroidal .750 Id X 1.450 Od X .544 Thk	2
... 79		083147	.. Grommet, Scr No 8/10 Panel Hole .312 Sq .500 High	2
... 80		219471	.. Bracket, Mtg Filter Board	1
... 81		219473	.. Bracket, Mtg CE Filter Ground Plane	1
... 82	PC4	229989	.. Circuit Card Assy, Filter	1
... 83		227746	.. Gasket, Inductor Mounting	1

+When ordering a component originally displaying a precautionary label, the label should also be ordered.
BE SURE TO PROVIDE MODEL AND SERIAL NUMBER WHEN ORDERING REPLACEMENT PARTS.

TRUE BLUE[®]

WARRANTY

Effective January 1, 2015
(Equipment with a serial number preface of MF or newer)

This limited warranty supersedes all previous Miller warranties and is exclusive with no other guarantees or warranties expressed or implied.

LIMITED WARRANTY – Subject to the terms and conditions below, ITW Welding Products Italy warrants to its original retail purchaser that new Miller equipment sold after the effective date of this limited warranty is free of defects in material and workmanship at the time it is shipped by Miller. THIS WARRANTY IS EXPRESSLY IN LIEU OF ALL OTHER WARRANTIES, EXPRESS OR IMPLIED, INCLUDING THE WARRANTIES OF MERCHANTABILITY AND FITNESS.

Within the warranty periods listed below, Miller will repair or replace any warranted parts or components that fail due to such defects in material or workmanship. Miller must be notified in writing within thirty (30) days of such defect or failure, at which time Miller will provide instructions on the warranty claim procedures to be followed. If notification is submitted as an online warranty claim, the claim must include a detailed description of the fault and the troubleshooting steps taken to identify failed components and the cause of their failure.

Miller shall honor warranty claims on warranted equipment listed below in the event of such a failure within the warranty time periods. All warranty time periods start on the date the equipment was delivered to the original retail purchaser or one year after the equipment is shipped to a European distributor or twelve months after the equipment is shipped to an International distributor.

1. 5 Years Parts — 3 Years Labor
 - * Original main power rectifiers only to include SCRs, diodes, and discrete rectifier modules with exclusion of STR, Si, STI, STH and MPi series.
2. 3 Years — Parts and Labor
 - * Engine Driven Welding Generators
(NOTE: Engines are warranted separately by the engine manufacturer.)
 - * Inverter Power Sources (Unless Otherwise Stated)
 - * Process Controllers
 - * Semi-Automatic and Automatic Wire Feeders
 - * Transformer/Rectifier Power Sources
3. 2 Years — Parts
 - * Auto-Darkening Helmet Lenses (No Labor)
 - * Migmatic 175
 - * HF Units
4. 1 Year — Parts and Labor Unless Specified
 - * Automatic Motion Devices
 - * Field Options
(NOTE: Field options are covered under True Blue[®] for the remaining warranty period of the product they are installed in, or for a minimum of one year — whichever is greater.)
 - * Induction Heating Power Sources, Coolers, and Electronic Controls/Recorders
 - * Motor-Driven Guns (w/exception of Spoolmate Spoolguns)
 - * Positioners and Controllers
 - * Powered Air Purifying Respirator (PAPR) Blower Unit (No Labor)
 - * Racks
 - * Running Gear and Trailers
 - * Subarc Wire Drive Assemblies
 - * Water Coolant Systems
 - * Work Stations/Weld Tables (No Labor)
5. 6 Months — Parts
 - * Batteries

6. 90 Days — Parts
 - * Accessory (Kits)
 - * Canvas Covers
 - * Induction Heating Coils and Blankets
 - * MIG Guns
 - * Remote Controls
 - * Replacement Parts (No Labor)
 - * Spoolmate Spoolguns
 - * Cables and Non-Electronic Controls

Miller's True Blue[®] Limited Warranty shall not apply to:

1. **Consumable components; such as contact tips, cutting nozzles, contactors, brushes, switches, slip rings, relays or parts that fail due to normal wear.**
2. Items furnished by Miller, but manufactured by others, such as engines or trade accessories. These items are covered by the manufacturer's warranty, if any.
3. Equipment that has been modified by any party other than Miller, or equipment that has been improperly installed, improperly operated or misused based upon industry standards, or equipment which has not had reasonable and necessary maintenance, or equipment which has been used for operation outside of the specifications for the equipment.

MILLER PRODUCTS ARE INTENDED FOR PURCHASE AND USE BY COMMERCIAL/INDUSTRIAL USERS AND PERSONS TRAINED AND EXPERIENCED IN THE USE AND MAINTENANCE OF WELDING EQUIPMENT.

In the event of a warranty claim covered by this warranty, the exclusive remedies shall be, at Miller's option: (1) repair; or (2) replacement; or, where authorized in writing by Miller in appropriate cases, (3) the reasonable cost of repair or replacement at an authorized Miller service station; or (4) payment of or credit for the purchase price (less reasonable depreciation based upon actual use) upon return of the goods at customer's risk and expense. Miller's option of repair or replacement will be F.O.B., Factory at ITW Welding Products Group Europe or F.O.B. at a Miller authorized service facility as determined by Miller. Therefore no compensation or reimbursement for transportation costs of any kind will be allowed.

TO THE EXTENT PERMITTED BY LAW, THE REMEDIES PROVIDED HEREIN ARE THE SOLE AND EXCLUSIVE REMEDIES. IN NO EVENT SHALL MILLER BE LIABLE FOR DIRECT, INDIRECT, SPECIAL, INCIDENTAL OR CONSEQUENTIAL DAMAGES (INCLUDING LOSS OF PROFIT), WHETHER BASED ON CONTRACT, TORT OR ANY OTHER LEGAL THEORY.

ANY EXPRESS WARRANTY NOT PROVIDED HEREIN AND ANY IMPLIED WARRANTY, GUARANTY OR REPRESENTATION AS TO PERFORMANCE, AND ANY REMEDY FOR BREACH OF CONTRACT TORT OR ANY OTHER LEGAL THEORY WHICH, BUT FOR THIS PROVISION, MIGHT ARISE BY IMPLICATION, OPERATION OF LAW, CUSTOM OF TRADE OR COURSE OF DEALING, INCLUDING ANY IMPLIED WARRANTY OF MERCHANTABILITY OR FITNESS FOR PARTICULAR PURPOSE, WITH RESPECT TO ANY AND ALL EQUIPMENT FURNISHED BY MILLER IS EXCLUDED AND DISCLAIMED BY MILLER.





Owner's Record

Please complete and retain with your personal records.

Model Name

Serial/Style Number

Purchase Date

(Date which equipment was delivered to original customer.)

Distributor

Address

Country

Zip/Postal Code



For Service

Contact a *DISTRIBUTOR* or *SERVICE AGENCY* near you.

Always provide Model Name and Serial/Style Number.

Contact your Distributor for:

Welding Supplies and Consumables

Options and Accessories

Service and Repair

Replacement Parts

Owner's Manuals

Contact the Delivering Carrier to:

File a claim for loss or damage during shipment.

For assistance in filing or settling claims, contact your distributor and/or equipment manufacturer's Transportation Department.

ITW Welding Italy S.r.l.

Via Privata Iseo, 6/E

20098 San Giuliano

Milanese, Italy

Phone: 39 (0) 2982901

Fax: 39 (0) 298290-203

email: miller@itw-welding.it

